

by ROADMASTER™ **BRAKEMASTER™**

PROPORTIONATE TOWED CAR BRAKING SYSTEM

roadmasterinc.com/patents for patent info

BrakeMaster 9060

for motorhomes with hydraulic brakes

Installation Instructions



Time Tested • Time Proven

ROADMASTER, Inc. • 6110 N.E. 127th Ave. • Vancouver, WA 98682
800-669-9690 • Fax 360-735-9300 • roadmasterinc.com
851811-23 11.20 © 1999-2020 ROADMASTER, Inc.

Welcome to the ROADMASTER family!

This manual has been prepared to acquaint you with the installation, operation, care and maintenance of your BrakeMaster, and to provide you with important safety information.

Read your owner's manual cover to cover. Understand how to install and operate your BrakeMaster, and carefully follow the instructions and safety precautions.

We thank you for your patronage and greatly appreciate your discerning taste.

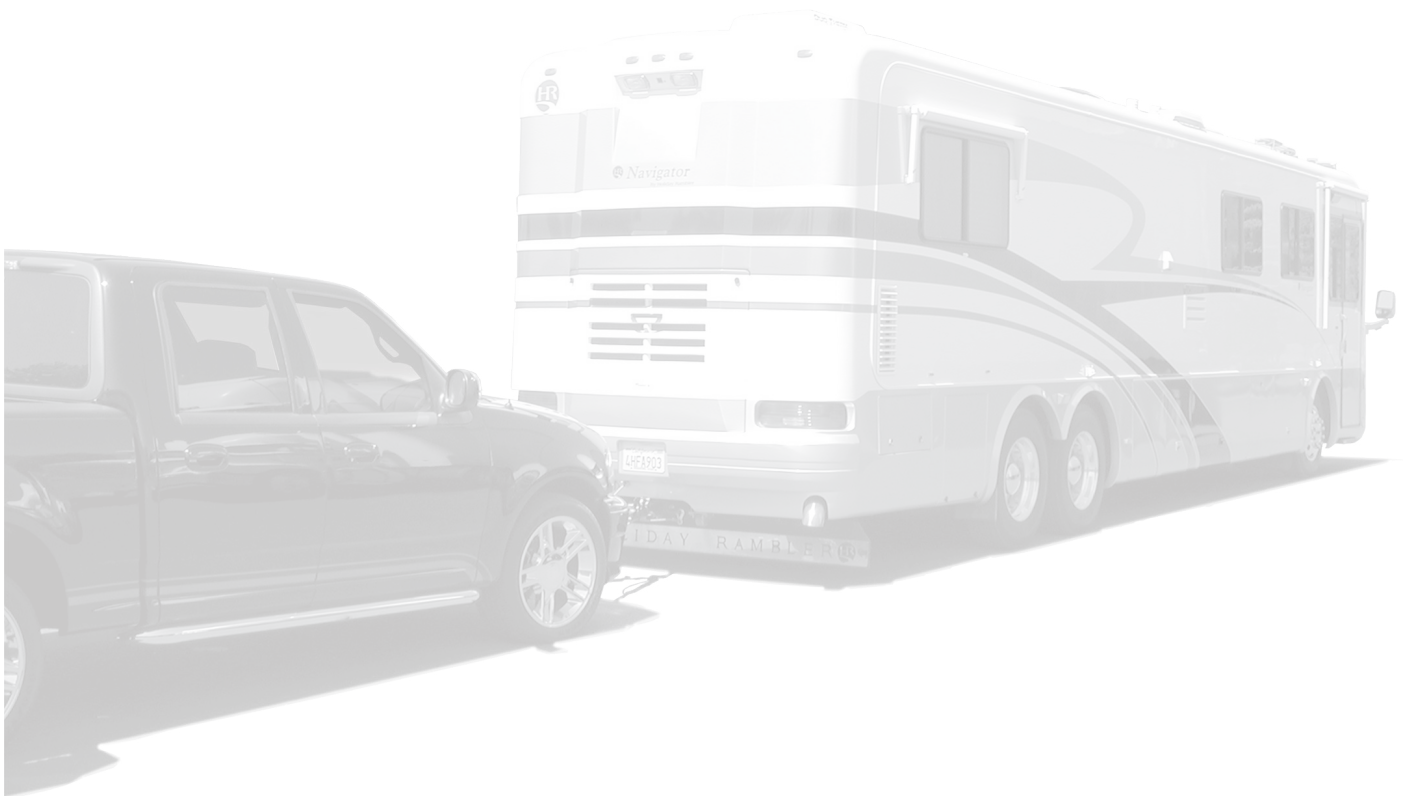

Table of Contents

Safety definitions	1	Install the proportioning valve.....	12-15
Before you begin the installation (installer's checklist)	2	Bleed the brakes	16-18
Wiring diagrams.....	3	Wire the proportioning valve.....	19
Air cylinder and air tank assembly parts lists	4	Install air lines in the motorhome	20
Install the seat bracket adapter	5	Install the motorhome monitor system.....	21-22
Install the break away system	5-7	Final connections and system test	23-24
Install air lines in the towed vehicle	8-9	Brake light solutions	25
Wire the air compressor	10-11	Install six diodes	26-27
		Troubleshooting	28-29
		Index.....	30

WARNING

These instructions pertain to the initial installation only. Operating instructions are contained in the owner's manual.

Read all instructions before installing or operating the BrakeMaster system. Failure to understand how to install or operate BrakeMaster could result in property damage, personal injury or even death.

IMPORTANT NOTICE!

Safety Definitions

These instructions contain information that is very important to know and understand. This information is provided for **safety** and to **prevent equipment problems**. To help recognize this information, observe the following symbols:

WARNING

WARNING indicates a potentially hazardous situation which, if not avoided, could result in property damage, serious personal injury or even death.

CAUTION

CAUTION indicates a potentially hazardous situation which, if not avoided, may result in property damage, or minor or moderate personal injury.

CAUTION

CAUTION used without the safety alert symbol indicates a potentially hazardous situation which, if not avoided, may result in property damage.

NOTE

Refers to important information and is placed in italic type. It is recommended that you take special notice of these items.

Before you begin the installation...

1. A vehicle-specific seat adapter is necessary to attach the BrakeMaster air cylinder to the floor of the towed vehicle. **This baseplate is not supplied with the kit; you must order it separately.**

Rarely, a seat adapter will not be available for a particular make and model of vehicle. In this case you must order a universal anchor plate kit (part number 450650-01). **Regardless of whether you use a seat adapter bracket or a universal anchor plate, you must have one or the other on hand before you begin the installation.**

To determine if a seat adapter is available for your vehicle, go to fitmaster.roadmasterinc.com – for vehicle-specific information. Select 'Towing Systems,' and enter the motorhome year, make and model, then 'Search.'

2. **If the battery must be disconnected for towing,** a stop light switch must be installed. Brake light switch kits for a number of vehicles are available through ROADMASTER; go to fitmaster.roadmasterinc.com – for vehicle-specific information. Select 'Towing Systems,' and enter the motorhome year, make and model, then 'Search.'

Note: If a brake light switch kit is listed on the web site for any particular vehicle, it is required.

Note: A Battery Disconnect (part number 766) is available for vehicles which must be towed with the battery disconnected.

If you choose to install the Battery Disconnect, a brake light switch is still required; a Brake-Lite Relay (see "Brake light solutions") is not required.

3. **If the vehicle to be towed has an 'active' (or, 'continuous power assist') braking system, or if the vehicle is not equipped with power brakes** – order the optional brake pressure reducer (part number 900002) to adapt the vehicle to the BrakeMaster system.

Vehicles with 'active' brake systems include several hybrid vehicles, such as the Ford Escape hybrid and the Mercury Mariner hybrid, as well as the H3 Hummer. These vehicles, and others with these systems, are designed so that even when the vehicle is set to 'tow' mode, the braking system is still active, thus requiring minimal pressure to engage the brakes.

CAUTION

If the vehicle to be towed has an 'active' braking system, or if the vehicle is not equipped with power brakes, install the optional brake pressure reducer.

If the reducer is not installed, BrakeMaster will apply excessive force to the towed vehicle's brake pedal, causing severe tire and/or brake system damage, as well as other, consequential damage.

4. **If fuse(s) must be removed from the vehicle be-**

fore it can be towed – verify that removing the fuse(s) will not disrupt power to BrakeMaster, or otherwise affect the installation or operation.

(To eliminate pulling fuses to tow, purchase a FuseMaster. Information about this product is available at fitmaster.roadmasterinc.com.)

5. **If the motorhome brake line has metric fittings** it will be necessary to use a metric-to-standard T-fitting to attach the proportioning valve. This fitting is not supplied in the kit.

Identify the size of the metric brake line before the installation. If it is 10 or 12 millimeters, contact ROADMASTER – T-fittings in both sizes are available.

The 10 millimeter T-fitting (part number 7923) fits virtually all metric brake lines for this application; the part number for the 12 millimeter fitting is 7921.

In the unlikely event that the brake line is not 10 or 12 millimeters, we recommend you contact a local hose and fitting shop or other contractor and arrange to have the brake line cut and flared so that the standard brake line tees supplied in the kit can be installed.

6. **If the motorhome has a one-piece brake line** (i.e., there are no brake line unions), or if the brake line unions are difficult to access, a short length of steel brake line will be necessary to connect the proportioning valve (see "Install the Proportioning Valve"). This section of steel brake line is not supplied; contact an auto parts store.

7. **Check the towed vehicle's brake lights** – BrakeMaster must function with the ignition key turned to the "tow" position; however, some vehicles' brake lights only operate with the key turned to the "on" position.

Check to see if this is the case: turn the ignition key to the "tow" position, apply the brakes, and check to see if the brake lights illuminate. If the brake lights do not illuminate, a two-prong brake light switch and 10-amp fuse must be installed.

Brake light switch kits for a number of vehicles are available through ROADMASTER; to see if one is available for any specific vehicle, visit www.roadmasterinc.com and select 'Vehicle Specific Info,' then 'Supplemental Braking Systems.' Enter the vehicle make, model and year, then scroll down the page.

Note: Check the owner's manual to see if the vehicle is equipped with an "automatic shut down" feature. If this is the case, ensure that the vehicle is not in automatic shut down mode before performing this test.

Note: If you must install a Brake-Lite Relay – see step 8, below – a brake light switch is not required.

8. **An optional Brake-Lite Relay may be required.** Refer to "Brake light solutions" for instructions on how to determine if the relay must be installed.

Note: A brake light switch (see steps 2 and 7 above) and a Brake-Lite Relay are mutually exclusive – if you use one, the other is not necessary.

WIRING DIAGRAMS

AIR COMPRESSOR

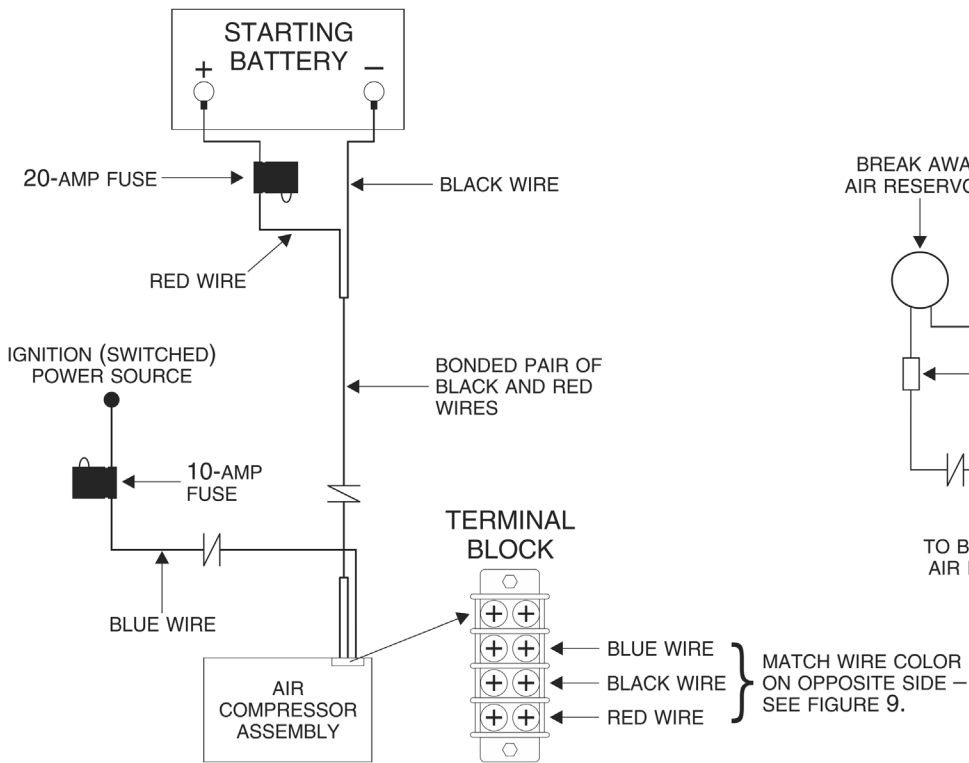

BREAK AWAY

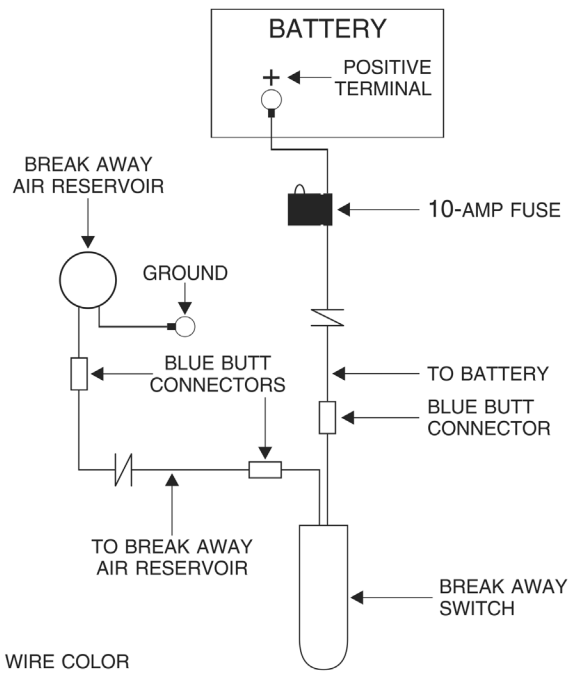

PROPORTIONING VALVE

SEPARATE BRAKE AND TURN

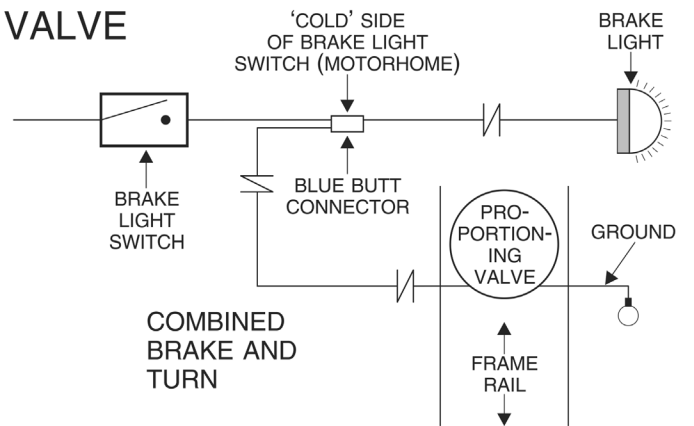
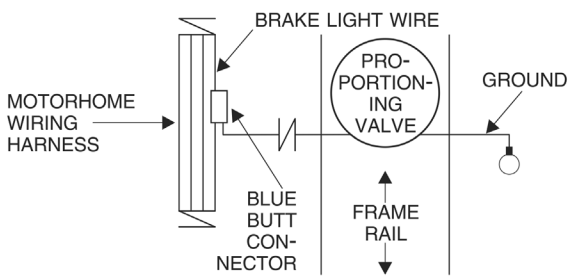

MOTORHOME MONITOR

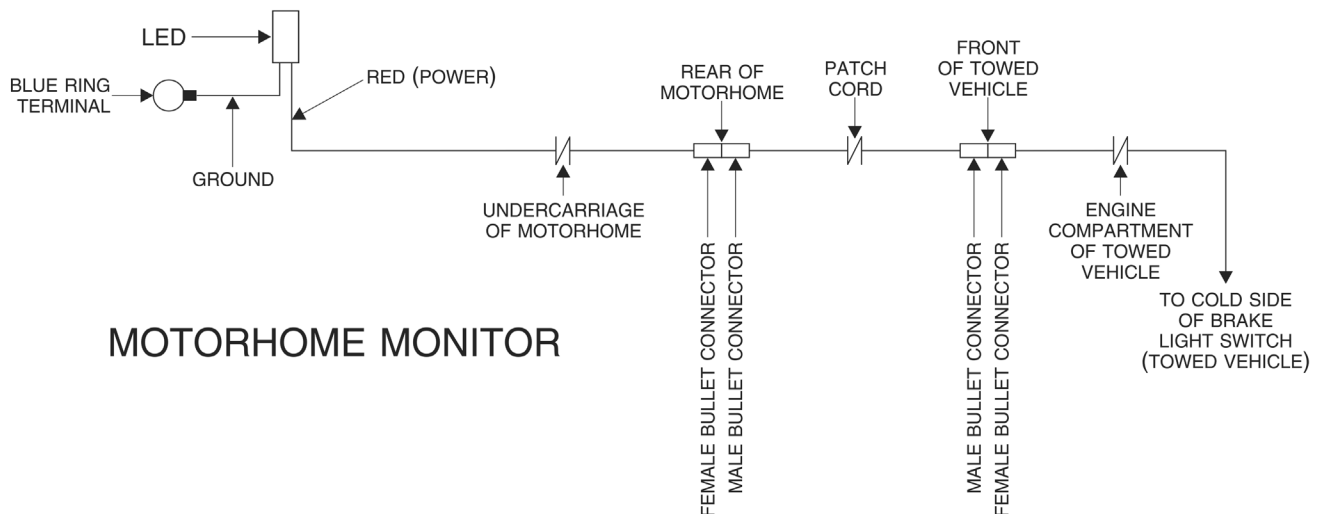

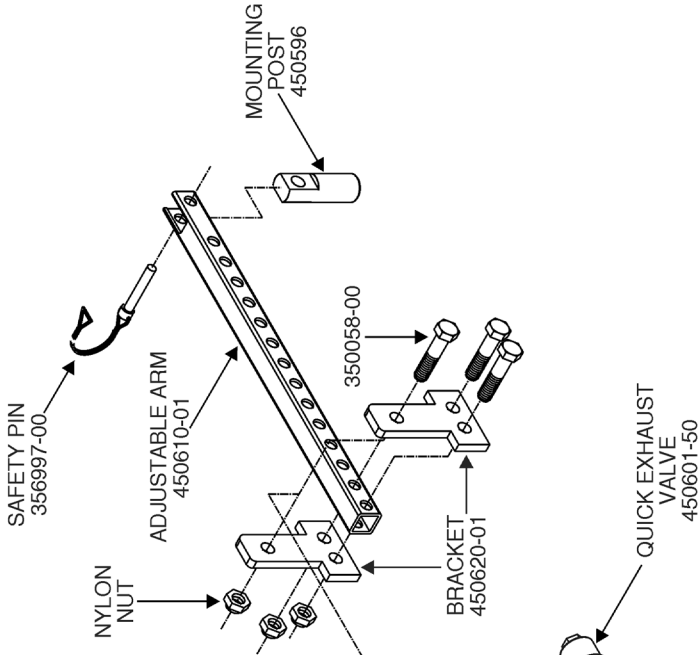

AIR CYLINDER ASSEMBLY

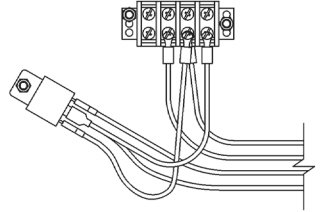
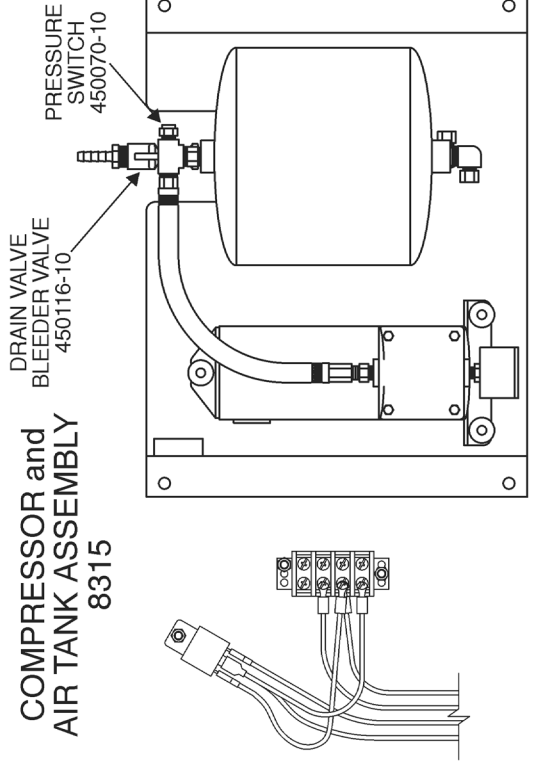
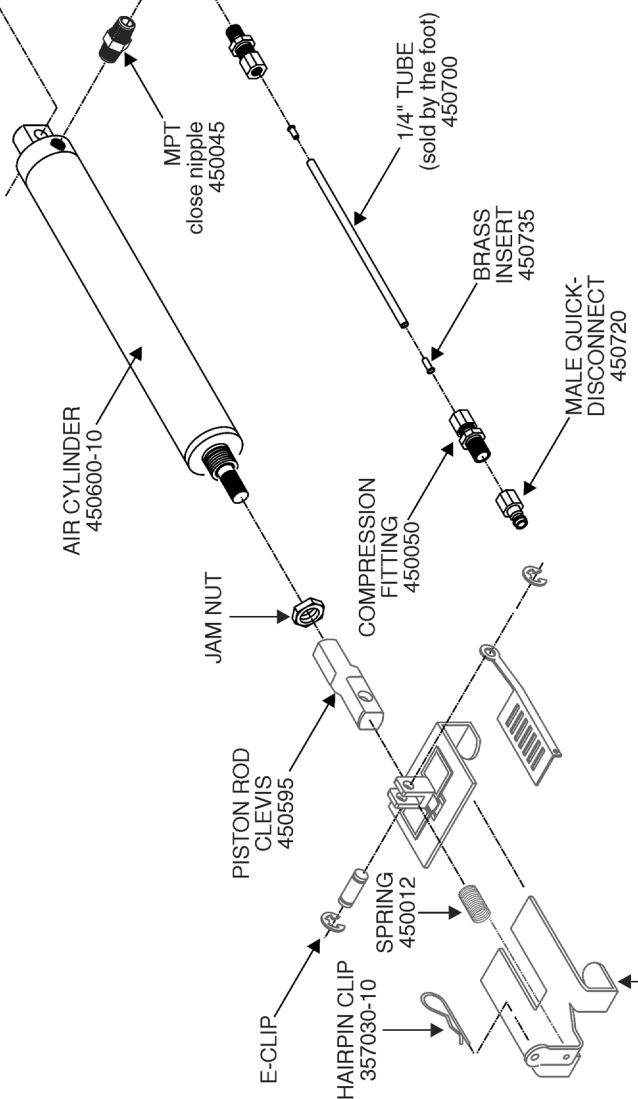

Install the seat adapter (or air cylinder anchor plate)

1. A vehicle-specific seat adapter is necessary to attach the BrakeMaster air cylinder to the floor of the towed vehicle. **This adapter is not supplied with the kit; you must order it separately.**

Rarely, a seat adapter will not be available for a particular make and model of vehicle. In this case you must order a universal anchor plate kit (part number 450650-01). **Regardless of whether you use a seat adapter bracket or a universal anchor plate, you must install one or the other now.**

The installation instructions for both the seat adapter brackets and for the universal anchor plate are contained in the kits.

To determine if a seat adapter bracket is available for your vehicle, go to fitmaster.roadmasterinc.com. Select the year, make and model and hit 'Submit.'

2. The BrakeMaster air cylinder will be in place after you have installed the seat bracket adapter. (For complete instructions on how to attach the air cylinder, refer to the BrakeMaster owner's manual.)

You can leave the air cylinder in position until you have attached an air line fitting (step 10, "Install air lines in the towed vehicle") or you can remove it if it interferes with the installation.

Install the break away system

Step A Install the air reservoir

1. Choose a location for the air reservoir (Figure 1). The air reservoir is mounted in the towed vehicle, most often in the engine compartment, but it may be attached anywhere an air line can be routed from the top of the air reservoir to the front of the vehicle, and where the drain valve (Figure 1), at the bottom of the reservoir, is easily accessible.

Choose a location that meets the following conditions:

- An air line will be attached to the reservoir in a later step. One end will be routed to the driver's side of the passenger compartment; the other end will be routed to the front of the vehicle. This air line cannot be closer than two feet from any heat source, such as the engine or exhaust system, which might damage the air line.
- The air reservoir must be mounted away from any moving parts, so that the air reservoir will not be damaged by, or interfere with, the proper operation of any components.
- Choose a location that will allow the bottom of the

air reservoir to be mounted lower than the top, so that any accumulated water can be drained from the tank. The reservoir cylinder does not have to be perfectly straight up and down, but the drain valve must be the lowest part of the reservoir.

- The reservoir will be attached with two of the supplied $\frac{1}{4}$ " x 1" hex bolts and nuts. Choose a location that will allow you sufficient access to tighten the hex nuts from the other side.

Note: because the air reservoir will be charged with compressed air, it cannot be mounted inside the passenger compartment of the vehicle.

2. Once you have chosen a location for the air reservoir, fold the two rubber clamps (Figure 1) over the cylinder. Press the ends of each clamp together, until the pre-drilled holes align.

Test-fit the reservoir and slide the clamps up or down the cylinder, if necessary, until the pre-drilled holes are both over a surface where the hex bolts and nuts will hold each clamp in place. Mark the center of each hole for drilling, and set the reservoir aside.

Before drilling, make certain you will not damage any components on the other side. Then, drill a $\frac{1}{4}$ " hole through the two points you have marked.

Before attaching the clamps, rotate the top of the reservoir so that the two wires at the solenoid valve (Figure 6), as well as the two brass air compression fittings (Figure 6), will be easily accessible.

Position the reservoir and clamps over the two holes, and secure the reservoir in place with one of the $\frac{1}{4}$ " x 1" hex bolts and nuts at each clamp.

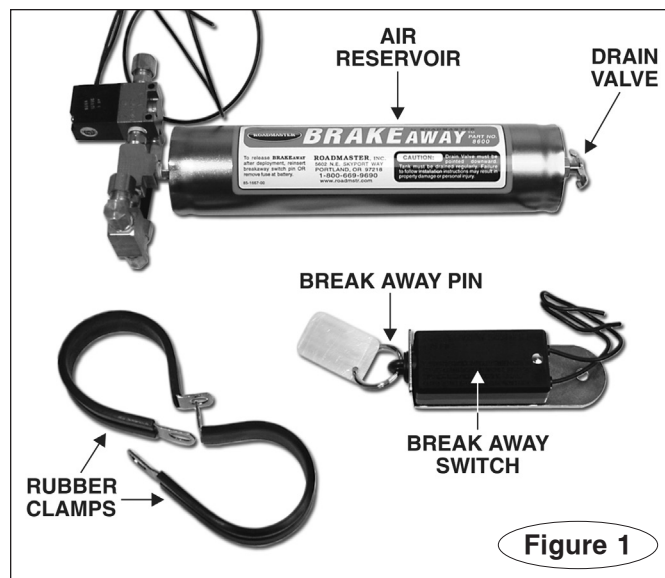

Step B Mount the break away switch

1. Mount the break away switch (Figure 1) at the front of the vehicle, on the driver's side. Choose an area you can easily reach, with a surface of sufficient strength to hold the switch firmly in place, so that the break away pin (Figure 1) will pull freely from the switch. Mount the

continued on next page

Install the break away system

continued from preceding page

switch in a horizontal position, with the break away pin facing toward the motorhome.

Ensure that the break away pin can be pulled freely away from the towed vehicle, without any obstructions.

WARNING

Do not attach the break away switch to the tow bar. In the unlikely event that the tow bar should separate, the break away switch will separate with it, preventing the break away system from activating. The towed vehicle's brakes will not be applied, which may cause property damage, personal injury or even death.

Step C Connect the wiring

1. Using one of the blue butt connectors, attach one end of the supplied length of black wire to the end of either one of the two wires extending from the break away switch. (If necessary, strip 1/4" to 3/8" of insulation from the end of the wires before connecting them.)

Next, route the wire to the positive terminal on the towed vehicle's battery (Figure 2), avoiding moving parts, sharp edges or "hot" components such as the engine or exhaust system. Where appropriate, use one or more of the included wire ties to secure the wire in place.

2. Cut the wire and strip 1/4" to 3/8" of insulation from the end of the wire.

Insert one of the supplied 10-amp ATC fuses into one of the provided fuse holders. The fuse holders are attached to a short length of wire, with a butt connector at one end and a ring terminal on the other. (See Figure 3.)

3. Use the butt connector to attach the short length of wire with the fuse holder and the 10-amp ATC fuse

to the end of the black wire.

Attach the ring terminal to the positive terminal on the towed vehicle's battery.

CAUTION

In order to prevent damage from a short circuit, the 10-amp fuse must be within six inches of the positive terminal. If the 10-amp fuse is farther than six inches, a short circuit may cause significant damage to the towed vehicle's electrical system, an electrical fire or other consequential, non-warranty damage.

4. Connect the remaining wire at the break away switch to either one of the two wires extending from the top

continued on next page

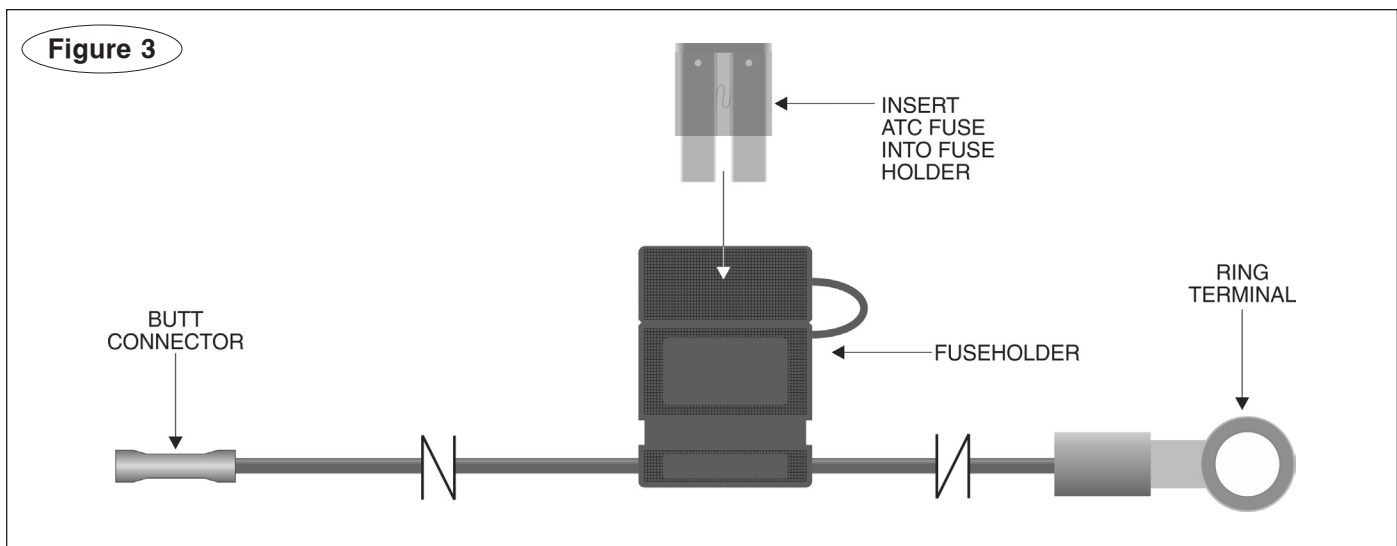
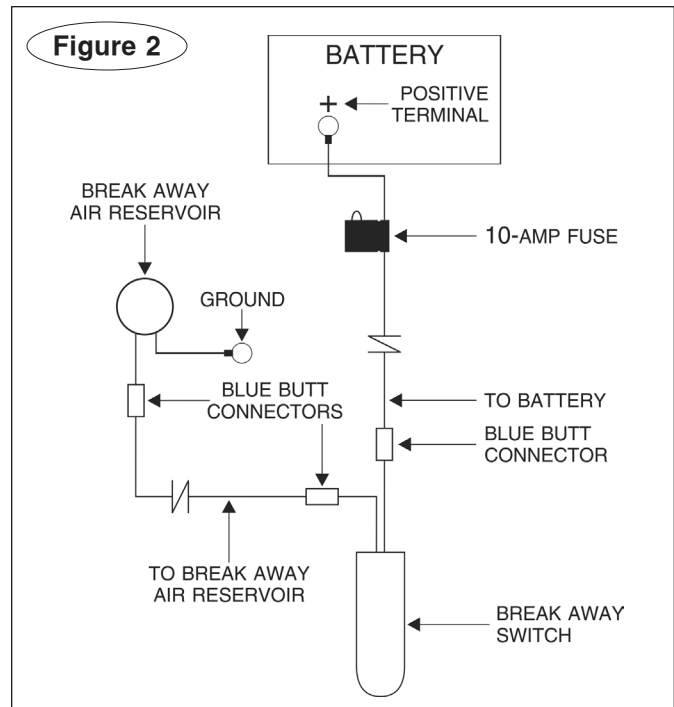

Install the break away system

continued from preceding page

of the solenoid valve on the air reservoir (Figures 2 and 6). If necessary, use the remaining length of black wire to reach the top of the solenoid valve. Connect the wires with the supplied blue butt connectors. Where appropriate, use one or more of the included wire ties to secure the wire in place.

5. Crimp the smaller (#10) ring terminal onto the end of the remaining wire extending from the top of the solenoid valve, and attach the ring terminal to any good chassis ground. (If necessary, use another butt connector, and any remaining black wire, to extend the length of the ground wire.)

6. If the battery must be disconnected for towing, install a battery switch to the positive battery cable, as shown in Figure 4. Connect the stop light switch wiring to the battery switch.

WARNING

If the battery must be disconnected for towing, a battery switch must be connected as shown in Figure 4. If it is not, the break away system will not function if the towed vehicle separates, which may cause property damage, personal injury or even death.

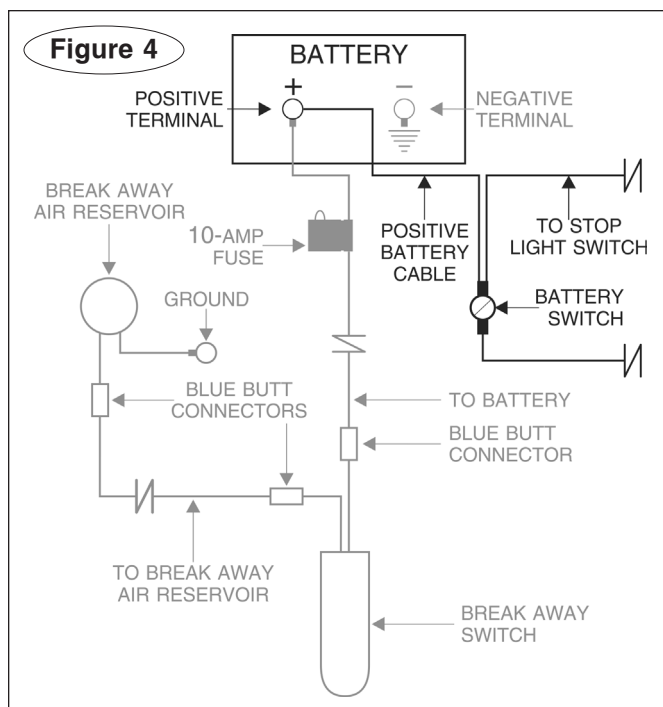

Install air lines in the towed vehicle

1. Find a suitable location at the front of the towed vehicle to attach the preassembled male quick coupler (Figure 5). Choose an area within easy reach, with a surface of sufficient strength to hold the mounting bracket firmly in place.

WARNING

Do not attach a female quick coupler at the front of the towed vehicle. The female quick couplers have an internal check valve to prevent air from escaping. If air pressure is not released, the Brake-Master pedal clamp will not retract when the system is activated, which will cause severe brake system damage, or a brake fire, as well as other consequential, non-warranty damage.

2. Attach the bracket with two of the supplied 1/4" nuts and bolts, with the male quick coupler pointing away from the towed vehicle.

Note: the weather covers will prevent dirt or debris from entering the lines. Keep the fittings covered when the braking system is not in use.

3. Connect one end of the air line to the male quick coupler compression fitting (Figure 5) – first, if necessary, trim the end of the air line, to make a smooth and straight cut. Then slide the compression nut and the compression sleeve (Figure 5) over the air line.

Next, slide one of the brass inserts (Figure 5) into the end of the line.

Note: if the brass inserts are omitted, the fittings will not be airtight.

Push the air line into the compression fitting, as far as it can go. Tighten the compression nut onto the fitting.

Note: if the compression nut is overtightened, the fitting will not be airtight. After completing the installation, check all the fittings for air leaks – see “Final connections and system test.”

4. Tape the open end of the air line. Then route the air line from the male quick coupler to the break away air-reservoir, avoiding moving parts, sharp edges or “hot” components such as the engine or the exhaust system.

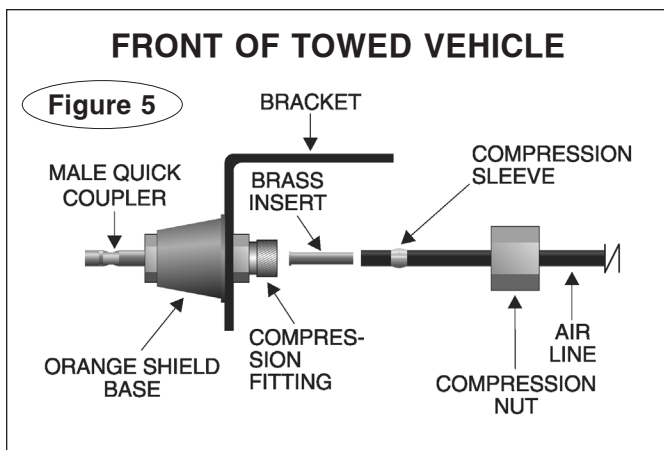

Do not kink the air line, or bend it to the extent that it crimps or creases.

Note: if the break away system was not installed, route the air line through the engine compartment and through the firewall – see step 7 below.

CAUTION

Do not position the air line closer than two feet from any heat source. The heat will soften the nylon, which will cause the air line to rupture.

If the air line is ruptured, the supplemental braking system will not function.

Do not kink the air line, or bend it to the extent that it crimps or creases – air pressure will be substantially reduced, or blocked entirely, at the kink in the line.

If the air pressure is reduced, the supplemental braking system will not function, or may only function intermittently.

Where appropriate, use wire ties to secure the air line in place.

5. At the top of the break away air reservoir (Figure 6), cut the air line to length and attach the open end to the brass “air in” compression fitting (Figure 6). Use the same method described in step 3 (above) to attach the air line.

6. Next, attach the end of another section of air line to the brass “air out” compression fitting on the top of the break away air reservoir (Figure 6). Use the same method described in step 3 (above) to attach the air line.

7. Tape the open end of the air line. Then route the air line from the break away air reservoir through the engine compartment and to the driver’s side of the firewall. As before, avoid moving parts, sharp edges or “hot” components such as the engine or the exhaust system. Do not kink the air line, or bend it to the extent that it crimps or creases.

Where appropriate, use wire ties to secure the air-line in place.

8. Next, look for a pre-existing hole in the firewall (or, *continued on next page*)

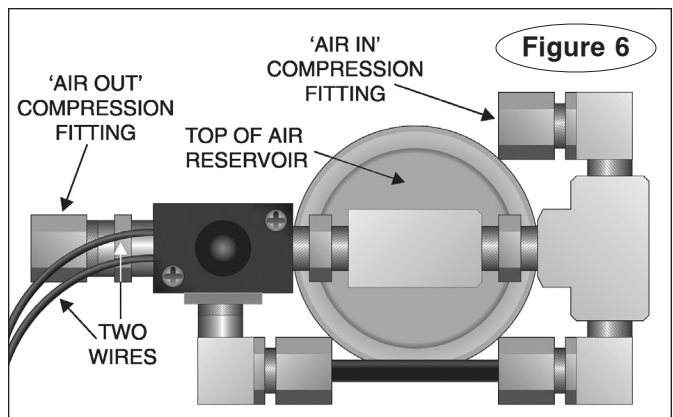

Install air lines in the towed vehicle

continued from preceding page

if there is sufficient space, a pre-existing wiring grommet) on the driver's side, to route the air line through the firewall.

If there is no pre-existing hole or grommet with sufficient space, drill a ½" hole through the firewall.

Drill from the engine compartment or from the interior of the vehicle, whichever is more convenient. Before drilling, make certain you will not damage any components on the other side of the firewall.

9. Fit the included firewall grommet into the ½" hole, and push the end of the air line through.

10. The air line will be connected to the preassembled female quick coupler **without** the orange shield base (Figure 7).

Find a likely mounting point for the bracket (Figure 7) on the driver's side – choose an area within easy reach, with a surface of sufficient strength to hold the mounting bracket firmly in place.

The bracket and quick coupler must not present an obstacle or hazard to the driver of the vehicle, or otherwise interfere with the operation of the vehicle.

Two common mounting points are: 1) under the dashboard, on the kick panel; or 2) far enough under the front of the driver's seat so that the quick coupler is accessible when the seat is slid back, but concealed when the seat is slid forward.

Or, depending on the interior design of the vehicle, there may be a more suitable mounting point.

Before attaching the bracket, first connect the BrakeMaster air cylinder assembly. Make certain that the male quick coupler at the end of the air line will reach the point you have chosen to attach the female quick coupler, without kinking either of the air lines.

Note: the quick exhaust valve on the air cylinder (see page 4) may be rotated, if this provides an easier connection.

Before attaching the coupler, make certain you will not damage any components on the other side.

If you have chosen to attach the bracket under the driver's seat, make certain that the female quick-coupler and bracket will not interfere with the normal movement of the driver's seat, or affect any adjust-

ments to the driver's seat.

- If you have chosen to attach the bracket to the kick panel, attach it with two of the supplied ¼" nuts and bolts, with the female quick coupler pointing toward the rear of the towed vehicle.

- If you have chosen to attach the bracket under the driver's seat, route the air line from the firewall to the front edge of the driver's seat. Remove the rocker panel or side trim (or, detach the carpeting) and conceal the air line underneath it.

Move the driver's seat back, as far as it will go.

Attach the bracket with two of the supplied ¼" nuts and bolts, with the female quick coupler pointing toward the front of the vehicle.

11. Cut the air line to length and attach it to the compression fitting on the female quick coupler. Use the same method described in step 3 (above) to attach the air line.

12. Seal the firewall grommet with a silicone sealant. Reattach the rocker panel (or side trim or carpeting), if it was removed.

13. Find a suitable location at the rear of the motorhome, near the center, to attach the remaining preassembled female quick coupler (**with** the orange shield base – Figure 8). Attach the bracket with two of the supplied ¼" nuts and bolts, with the female quick coupler pointing away from the motorhome.

Note: the weather covers will prevent dirt or debris from entering the lines. Keep the fittings covered when the braking system is not in use.

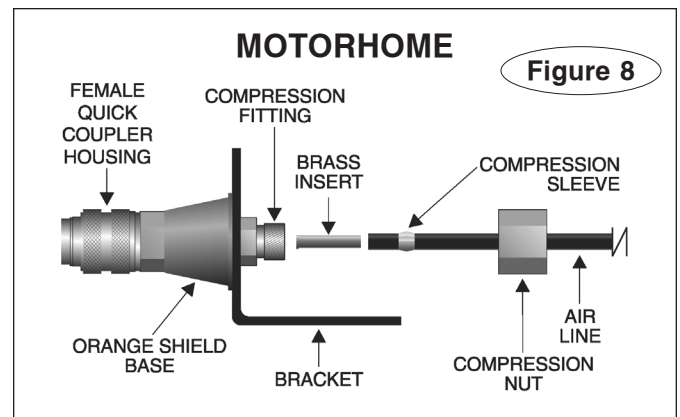
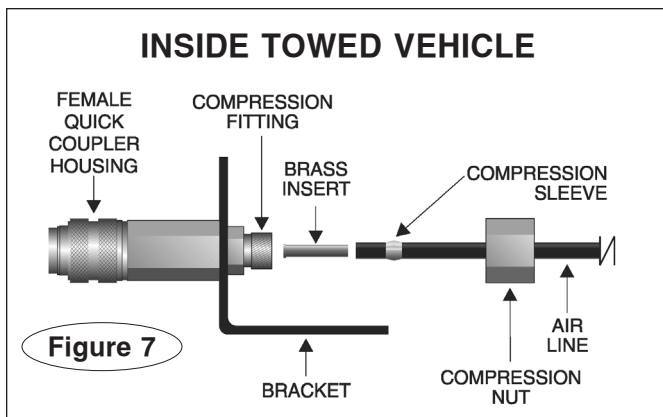

Wire the air compressor

1. Before wiring the air compressor (Figure 9), first choose a mounting location – the air compressor assembly must be installed in a clean, dry area (ideally, a storage compartment), within 20 feet of the motorhome starting battery.

The compressor is attached with four screws – one at each corner of the air compressor housing. The surface and underlying material at these four points must provide sufficient support to hold the compressor firmly in place.

The compressor may be mounted horizontally or vertically; however, it must be mounted so that the drain (Figure 9) is pointing down. Condensation in the air tank must be drained periodically, through this valve. A short length of rubber hose is included for this purpose – the hose can be attached to the valve and routed to the exterior of the motorhome. If possible, choose a mounting location for the compressor where a ½" hole can be drilled near the drain valve, through to the exterior of the motorhome.

CAUTION

Do not mount the air compressor...

- in a slide-out, or near moving components – the wiring and/or the compressor may detach.
- near any heat source such as the engine, exhaust system or muffler – excessive heat will damage the wiring, tubing or other components, which will cause the compressor to fail.
- where it will be exposed to the elements – if the air compressor is mounted near the front grille, for example, it may draw an excessive amount of

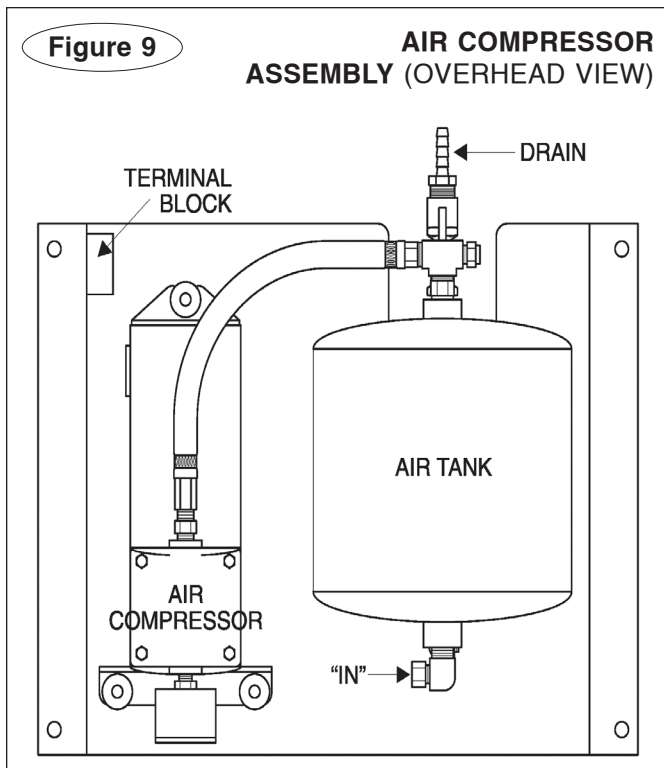

dirt, dust or road debris into the air tank and then into the air lines, which may damage components connected to the air lines.

Failure to follow these instructions may cause non-warranty damage to the air compressor, the air cylinder, or other components of the braking system.

2. Position the air compressor at the mounting location you have chosen. Using the four pre-drilled holes in the housing (one at each corner) as templates, drill four pilot holes. Before drilling, make certain you will not damage any components on the other side.

Do not attach the air compressor now – in most cases, it will be considerably easier to connect the wiring (and, later, the air lines) with the compressor loose.

3. Route the bare end of the bonded pair of black and red wires from the motorhome starting battery to the air compressor.

CAUTION

Do not use an auxiliary (“house”) battery as a power source for the air compressor – the auxiliary battery may be near capacity. Any additional power draw may blow the fuse(s) to electrical components already connected to the auxiliary battery.

Avoid moving parts (slide-outs, sliding generators, sliding battery trays, etc.), sharp edges or “hot” components, such as the engine or exhaust system, as you route the wire from the starting battery to the air compressor. Where appropriate, use one or more of the included wire ties to secure the wire in place.

4. At the air compressor, cut the bonded pair of black and red wires to length. Using one of the small ring terminals, attach the red wire to the terminal block screw opposite the pre-attached red wire (Figure 10).

Next, use another small ring terminal to attach the black wire to the terminal block screw opposite the black wire
continued on next page

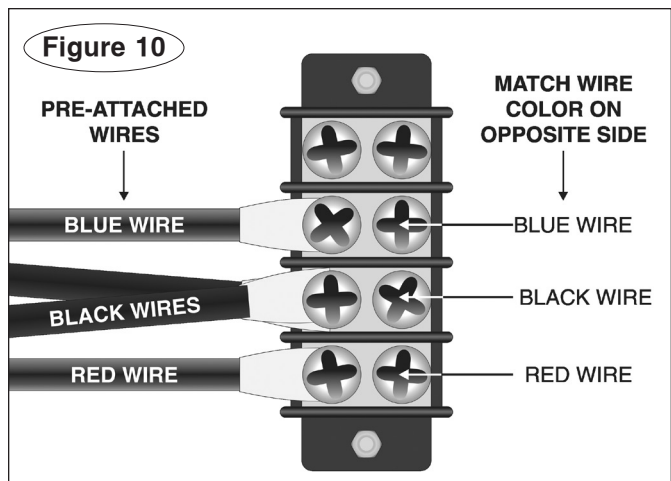

Wire the air compressor

continued from preceding page
pre-attached black wires (Figure 10).

Note: due to manufacturing variances, the pre-attached red and black wires may be mounted to different terminal block screws than those shown in Figure 10. If this is the case, match color to color – red wire opposite red wire and black wire opposite black wires.

5. At the starting battery, insert the supplied 20-amp ATC fuse into one of the provided fuse holders. The fuse holders are attached to a short length of wire, with a butt connector at one end and a ring terminal on the other (Figure 3).

Use the butt connector to attach the short length of wire with the fuse holder and the 20-amp ATC fuse to the end of the red wire. (See the electrical schematic on page three.)

6. At the starting battery, attach one of the large ring terminals to the end of the black wire.

The red wire will be connected to the positive terminal of the starting battery; the black wire will be connected to the negative terminal. To eliminate the possibility of personal injury or equipment damage, do not connect the wires until the installation is complete.

WARNING

The 20-amp fuse must be installed at the positive terminal. If a short circuit develops and the fuse is not in place, the battery and other equipment may be damaged; additionally, sparks may cause an electrical fire or a battery explosion.

7. Choose the most convenient ignition (switched) power source from the motorhome – any 12VDC+ source which is powered only when the motorhome's ignition is turned on. Route the bare end of the supplied length of blue wire from this point to the air compressor.

As before, avoid moving parts, sharp edges or “hot” components, such as the engine or exhaust system, as you route the blue wire to the air compressor. Where appropriate, use wire ties to secure the wire in place.

8. At the air compressor, cut the blue wire to length. Using one of the small ring terminals, attach the blue wire to the terminal block screw labeled “blue wire” in Figure 10.

Note: due to manufacturing variances, the pre-attached blue wire may be mounted to a different terminal block screw than the one shown in Figure 10. If this is the case, match color to color – blue wire opposite blue wire.

9. Insert the remaining 10-amp ATC fuse into the last of the provided fuse holders. As in step 5, attach the fuse holder and ring terminal to the end of the blue wire with the butt connector (Figure 3).

the 10-amp fuse must be within six inches of the electrical connection. If the fuse is farther than six inches, a short circuit may cause significant damage to the towed vehicle's electrical system, an electrical fire or other consequential, non-warranty damage.

The blue wire will be connected to the ignition power source you chose in step 7. To eliminate the possibility of personal injury or equipment damage, do not connect the blue wire until the installation is completed.

CAUTION

In order to prevent damage from a short circuit,

Install the proportioning valve

WARNING

If the motorhome is raised at any time during the installation, it must be on a hoist or safely and securely supported and blocked.

If the motorhome is equipped with an air suspension system and a line to the air suspension system is inadvertently opened, or if the motorhome's air suspension system is turned off, the motorhome will lower to the ground.

The motorhome may unexpectedly roll forward or backward, especially if it is on an incline, if it is not blocked.

1. The proportioning valve (Figure 13) will be installed on the frame of the motorhome chassis, and attached to the brake line.

First, choose a location for the proportioning valve – find the steel brake line that is routed along the frame. If the motorhome is a Class A, there may be a brake union (Figure 11) every ten to 15 feet, where two

sections of brake line are connected. The proportioning valve must be installed near one of these brake unions.

However, some Class A motorhomes, and most Class C motorhomes, have a one-piece brake line, from the front to the rear. There are no brake unions on these motorhomes.

If there are no brake unions, or the brake unions are difficult to access, there are two installation options:

- Follow the steel brake line forward, until it joins with another fitting. This is the point where you can tee into the brake line, as described later.
- Follow the steel brake line back, until it joins a rubber brake hose (Figure 12). This junction is the second possible location to tee into the brake line.

Since the brake tee will not thread onto the rubber brake hose, it will be necessary to attach a short section of steel brake line and install the brake tee as shown in Figure 13. This section of steel brake line is not supplied; contact an auto parts store.

continued on next page

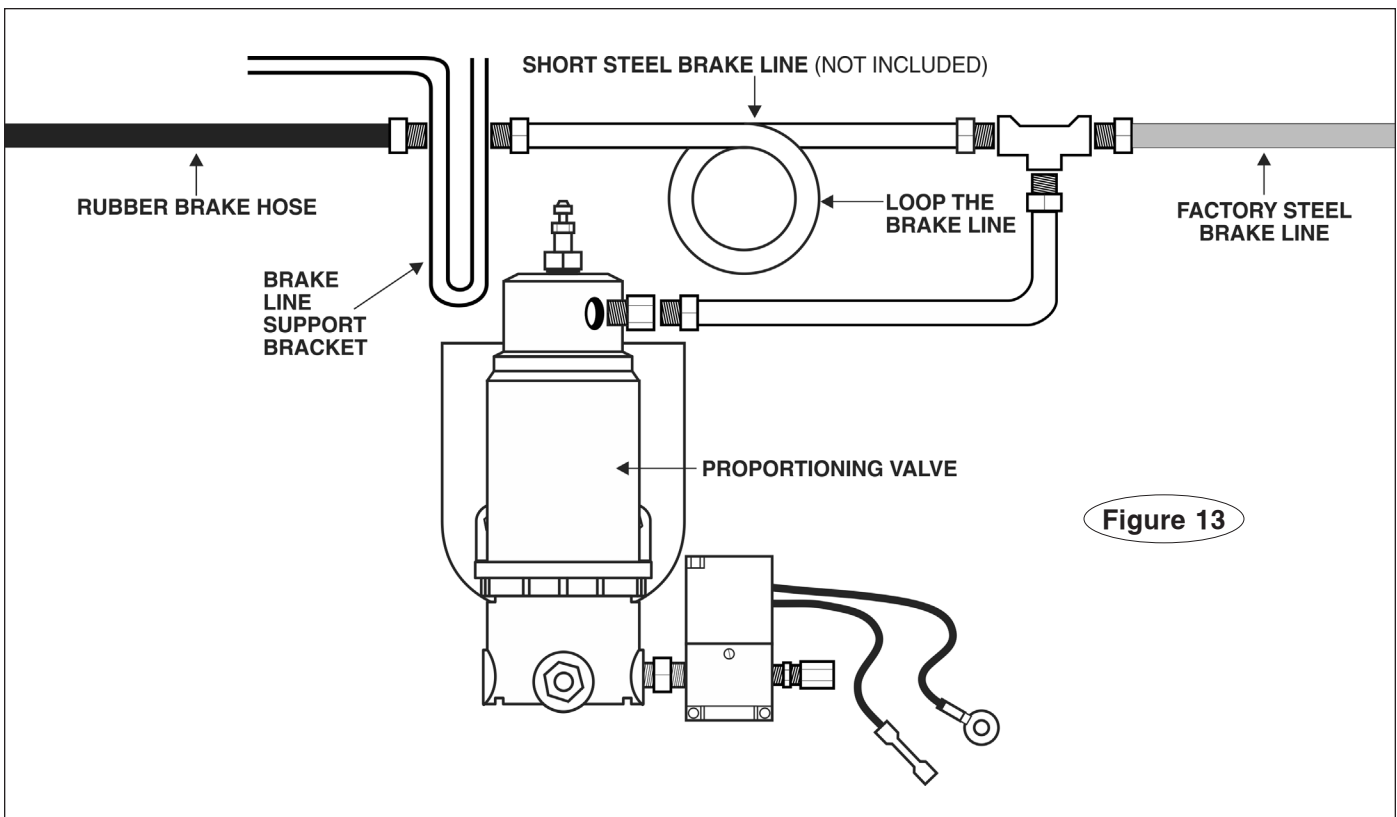
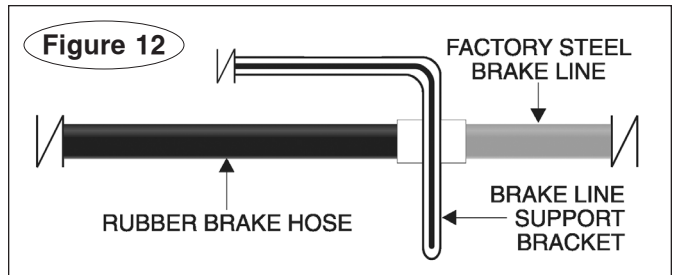
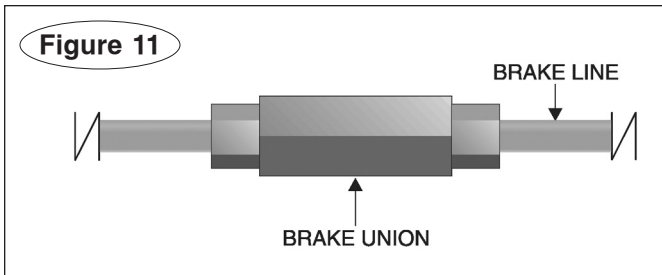

Install the proportioning valve

continued from preceding page

WARNING

Loop the section of steel brake line, as shown in Figure 13, so that it can expand and contract to absorb road vibrations. Otherwise, this section of brake line may detach or break, which will cause a loss of brake pressure.

CAUTION

If you are installing BrakeMaster in a Ford Class C motorhome, tee into the front hydraulic brake line. The rear hydraulic brake line does not supply sufficient hydraulic pressure to brake the towed vehicle properly.

2. Determine the best location to attach the proportioning valve bracket, based on the following:

A. There must be adequate room on the frame to mount the proportioning valve assembly (Figure 14) securely in place.

B. When the proportioning valve is installed, the bleeder valve (Figure 14) must point up.

C. The proportioning valve and its attachments must not interfere with the movement or proper operation of any chassis components.

Also, there must be sufficient clearance to bolt the proportioning valve bracket to the frame without causing damage to any other component.

D. The proportioning valve assembly must be installed close enough to the motorhome's brake line to allow the included section of brake line to reach the brake union (or other point you have chosen to tee into the brake line).

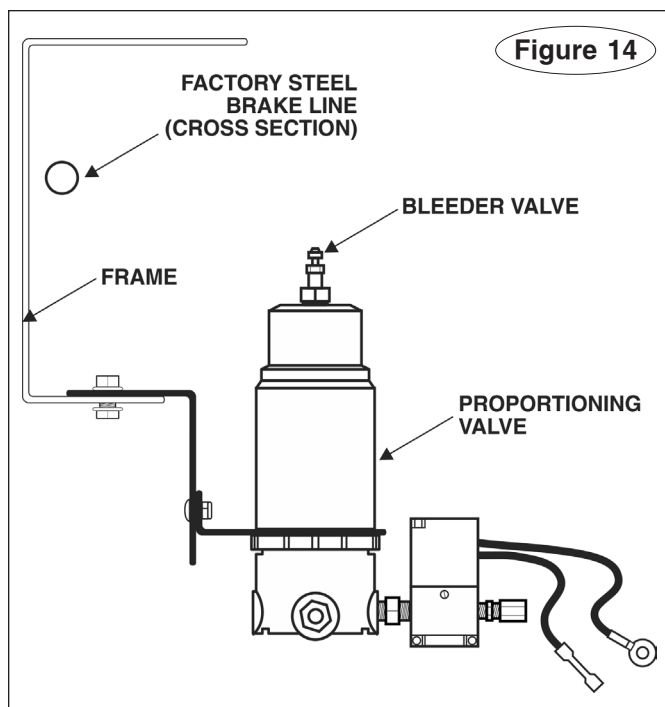

E. The closer the proportioning valve is to the air compressor, the less air line will have to be routed between them later.

WARNING

The proportioning valve must be mounted with the bleeder valve pointing up. The valve will not bleed the brake system if it is not pointing up, which will cause brake failure.

3. Before attaching the proportioning valve, first remove any residual vacuum from the motorhome's brake power booster (if the motorhome is so equipped) – apply the motorhome brake several times, with the engine off.

4. Next, remove the master cylinder reservoir cover and (if necessary) fill the reservoir with brake fluid, up to the maximum marking. Reattach the cover.

WARNING

Wear appropriate eye protection when working on the brake system. If brake fluid comes into contact with your eyes, follow the manufacturer's instructions.

Failure to follow these instructions may cause severe eye injury.

Note: If the motorhome brake line has metric fittings it will be necessary to use a metric-to-standard T-fitting to attach the proportioning valve. This fitting is not supplied in the kit.

Identify the size of the metric brake line before the installation. If it is 10 or 12 millimeters, contact ROAD-MASTER – T-fittings in both sizes are available.

The 10 millimeter T-fitting (part number 7923) fits virtually all metric brake lines for this application; the part number for the 12 millimeter fitting is 7921.

In the unlikely event that the brake line is not 10 or 12 millimeters, we recommend you contact a local hose and fitting shop or other contractor and arrange to have the brake line cut and flared so that the standard brake line tees supplied in the kit can be installed.

5. Position a bucket or pan under the brake union (or other point you have chosen to tee into the brake line) to catch any brake fluid.

Clean any dirt or debris away from the brake union and use two open end or line wrenches to disconnect both ends of the brake line from the union. (It may be necessary to soak the connections with penetrating oil to break them free.)

Do not bend the brake line, or damage the threads.

When the brake line is disconnected from the union, plug the line going toward the master cylinder to prevent any further loss of brake fluid. A rubber plug (part number 450011) is included in the kit for this purpose.

continued on next page

Install the proportioning valve

continued from preceding page

CAUTION

Check the brake fluid level often after the brake line is disconnected, and while the proportioning valve is being installed. Add brake fluid as necessary to prevent the brake fluid level from falling low enough to allow air bubbles into the master cylinder. If air is allowed into the brake system from the master cylinder, all brakes, and any components connected to the hydraulic brake system, must be bled.

6. At the mounting location you have chosen, use the two pre-drilled holes in the proportioning valve bracket (Figure 15) as templates to mark and drill two 3/8" holes through the frame.

Use the two supplied 3/8" bolts and nuts to attach the proportioning valve to the frame, as shown in Figure 15.

7. Use a ring terminal to ground the solenoid valve (Figure 16) by connecting one of the black wires from the solenoid valve to any good chassis ground.

8. Determine the correct size of brake tee to use (both 1/4" and 3/16" tees are included) and then connect it to the two factory steel brake lines, as shown in Figure 16.

Note: if the brake tee is pointing up when the brake lines are connected, less brake fluid will be lost.

9. Next, connect the brake tee (Figure 16) to the port (Figure 16) on the proportioning valve, with one of the provided sections of brake line (Figure 16). Two sizes of brake line are provided for this purpose – 1/4" and 3/16".

A. If the motorhome has 1/4" brake lines – thread it

into the fitting on the port on the proportioning valve.

B. If the motorhome has 3/16" brake lines – screw the flair adapter (Figure 17) onto the fitting on the port on the proportioning valve. Then, attach the brake line to the flair adapter, as shown in Figure 17.

Note: the port can be rotated up to one full turn counterclockwise for easier connection to the section of brake line – hold the bottom section of the valve (Figure 16) in place with adjustable pliers. With another

continued on next page

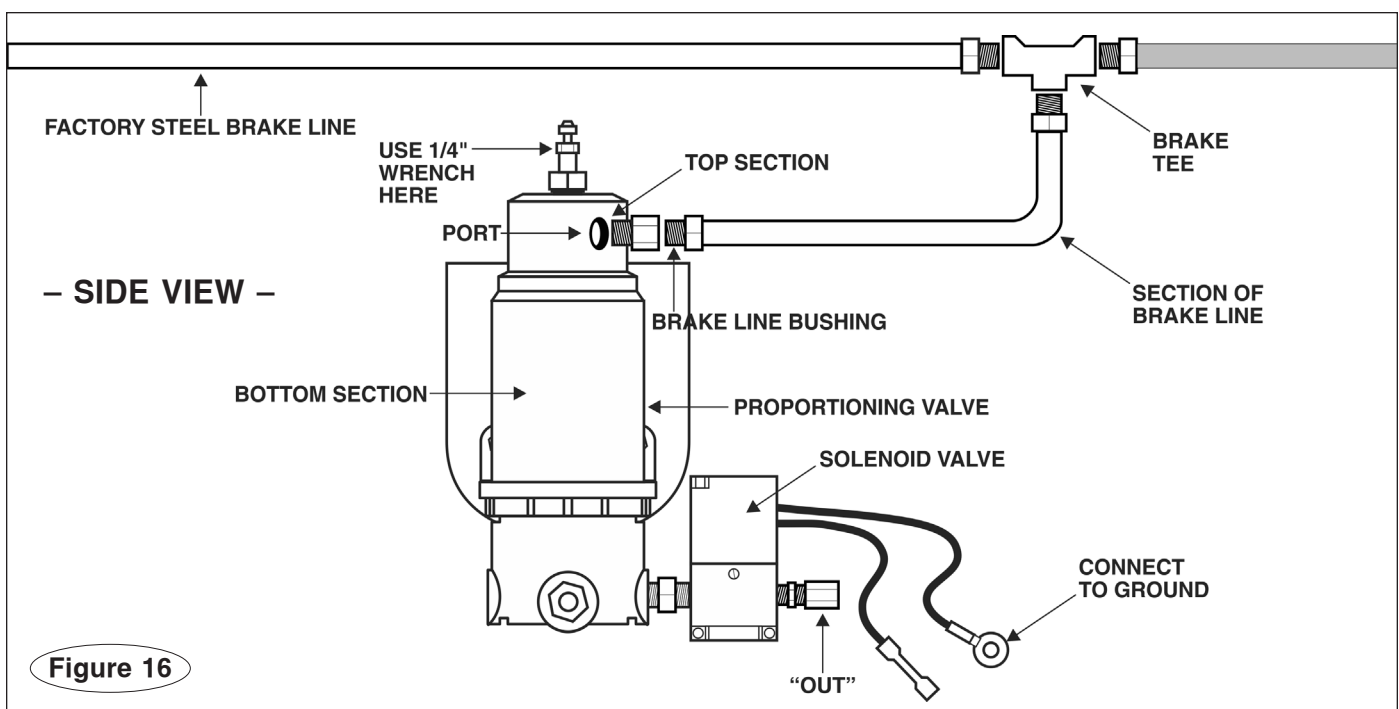
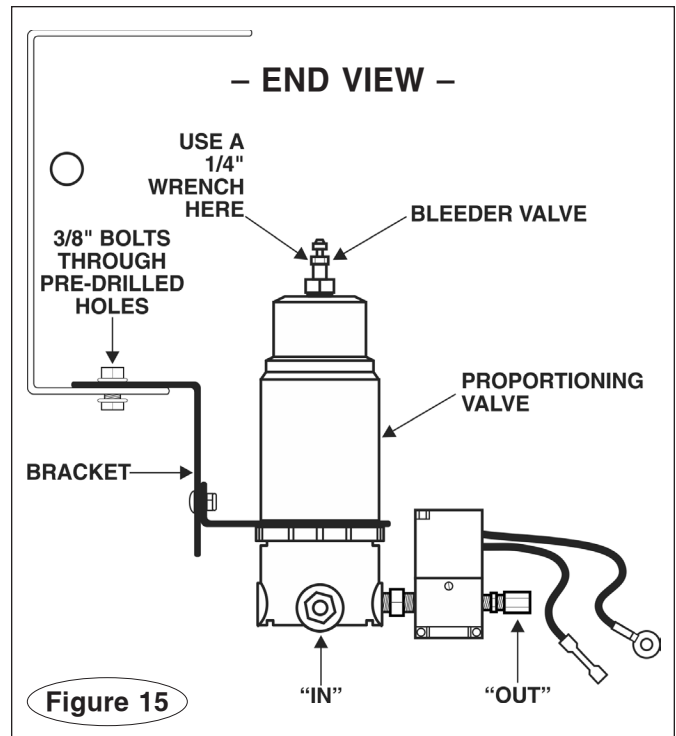

Install the proportioning valve

continued from preceding page

pair of pliers, turn the top section (Figure 16) until the port is at the correct position.

Although it has been unthreaded, the top section of the proportioning valve will be held in place by the brake line.

10. Connect the section of brake line to the tee.

In most cases, it will be necessary to bend the section of brake line – use extreme care not to kink the brake line. If the brake line is kinked, it must be replaced with another section of brake line.

WARNING

If the section of brake line between the proportioning valve and brake tee is kinked, replace it with another section of brake line.

A kink in the brake line will cause brake failure, which may result in property damage, personal injury or even death.

11. The proportioning valve is now installed.

Note: you will test the system after all components have been installed. However, if you choose to test the proportioning valve now, make certain that the motorhome engine is turned on.

The process of installing the valve has allowed air to enter the brake system. The air in the proportioning valve, as well as the air in the brake lines, must be bled before the motorhome is driven.

12. To bleed the air out of the proportioning valve, loosen the bleeder valve (Figure 15) at the top of the proportioning valve with a ¼" wrench. Do not loosen the ½" fitting below it.

When brake fluid becomes visible at the top of the proportioning valve, tighten the bleeder valve. Wipe away the excess brake fluid from the top of the proportioning valve with a dry, clean rag.

After the air is bled from the proportioning valve, as described above, proceed to the next section – “Bleed the brakes.”

WARNING

After the proportioning valve is installed, bleed the air from the valve (as described above), as well as the motorhome's brake system, before driving the motorhome.

Failure to bleed the brakes will cause a reduction in braking efficiency or a complete loss of brake pressure.

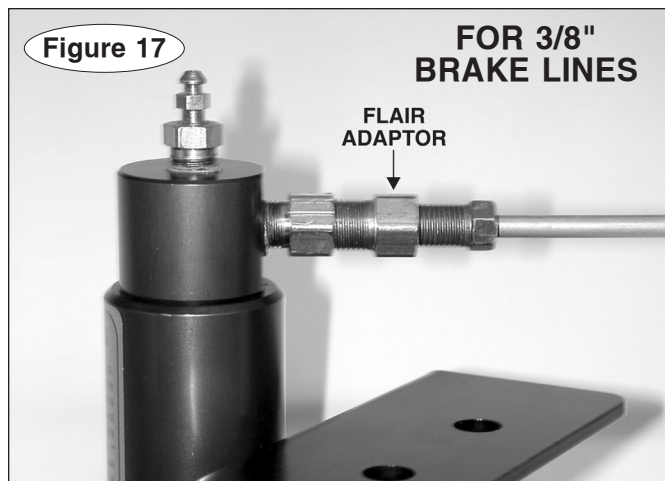

Bleed the brakes

WARNING

After the proportioning valve is installed, bleed the air from the valve (as described in step 12 under “Install the proportioning valve”), as well as the motorhome’s brake system, before driving the motorhome.

Failure to bleed the brakes will cause a reduction in braking efficiency or a complete loss of brake pressure.

Cautions and warnings

Follow the cautions and warnings below whether you choose the specific brake line method, the traditional method or either of the one-person methods.

CAUTION

Check the brake fluid level often while bleeding the brakes. Add brake fluid as necessary to prevent the brake fluid level from falling low enough to allow air bubbles into the master cylinder.

If air is allowed into the brake system from the master cylinder, all brakes, and all components connected to the hydraulic brake system, must be bled.

Failure to follow these instructions may result in a complete loss of braking pressure, which may cause property damage, personal injury or even death.

WARNING

Wear appropriate eye protection when working on the brake system. If brake fluid comes into contact with your eyes, follow the manufacturer’s instructions.

Failure to follow these instructions may cause severe eye injury.

For ABS (anti-lock braking systems)...

The front of an ABS system can be bled in the same manner as the traditional method described below. However, the rear brakes must be bled with a pressurized bleeder system, or, the hydraulic accumulator must be fully charged.

The hydraulic accumulator can be charged by starting the engine.

Specific brake line method

This method bleeds the air from only one wheel cylinder – one of the cylinders on the brake line with the proportioning valve.

Use the following instructions only if air has not been allowed into the brake lines from the master cylinder. If air has entered the brake lines through the master cylinder, you must bleed all brake lines, and all components connected to the hydraulic brake system – follow the instructions under “Traditional method” (below).

Installing the BrakeMaster proportioning valve will typically allow only a small amount of air to enter only one of the motorhome’s brake lines. However, it must travel from the proportioning valve to a wheel cylinder before it can be released – in some cases, a distance of 30 or more feet.

It is necessary to draw enough brake fluid to pull the air to the wheel cylinder. The amount of brake fluid that must be released will vary from one motorhome to another, depending on the distance from the proportioning valve to the wheel cylinder.

Which wheel cylinder you will bleed depends on the type of motorhome – for Class C motorhomes, bleed the front wheel cylinder on the brake line with the proportioning valve; for Class A motorhomes, bleed the rear wheel cylinder on the brake line with the proportioning valve.

This method requires:

- an assistant (to pump the brake pedal)
- a box-end wrench suitable for the vehicle’s bleeder screws (An offset wrench allows the most movement.)
- a supply of brake fluid
- a disposable container
- a length of clear plastic tubing to fit over the bleeder screws (The tubing must have an inner diameter which will allow it to seal over the bleeder screws).

1. Remove the master cylinder reservoir cover and fill the reservoir with brake fluid (if necessary) up to the maximum marking. Reattach the cover.

Check the brake fluid level frequently while bleeding the brakes.

2. Loosen the bleeder screw at the wheel cylinder. Remove the rubber cap (if present).

3. Position the box-end wrench over the bleeder screw.

4. Place one end of the clear plastic tubing over the nipple of the bleeder screw, and place the other end of the tubing into the disposable container.

5. Instruct the assistant to “apply.” The assistant should pump the brake pedal three times, then hold the pedal down firmly, and respond with “applied.”

6. Loosen the bleeder screw with a brief quarter turn, just enough to allow a solid stream of brake fluid to flow through the tubing. (The brake pedal will “fall” to the floorboard as the bleeder screw is opened. Instruct

continued on next page

Bleed the brakes

continued from previous page

the assistant in advance not to release the brakes until instructed.)

Watch for air bubbles in the brake fluid as it empties into the disposable container. This is the air that was allowed into the system when the proportioning valve was installed.

7. When these air bubbles have emptied into the container, close the bleeder screw by tightening it gently.

8. Instruct the assistant to “release” the brakes.

Note: do not release the brake pedal while the bleeder screw is open – air will be pulled into the system.

The assistant should respond with “released.”

9. Depending on the distance from the proportioning valve to the wheel cylinder, it may be necessary to repeat the “apply” and “release” sequence. Continue to do so until air bubbles are no longer present.

Check the brake fluid level in the master cylinder reservoir after each sequence. Add fluid, as necessary, to keep the level at the maximum marking.

When the brake line has been bled, check and refill the master cylinder reservoir again, if necessary.

10. Replace the rubber cap you removed earlier (if one was present).

11. Inspect the bleeder screw and other fittings for leaks. Correct, if necessary. Inspect the proportioning valve and the brake line fittings at the six points indicated in Figure 18 and correct, if necessary.

12. Depress and release the brake pedal several times – it should feel firm and solid when it is depressed. If the brake pedal does not provide firm resistance, there is air in the brake line. Bleed the brake line again, as described above.

WARNING

If the brake pedal does not provide firm resistance after the brakes have been bled, bleed the

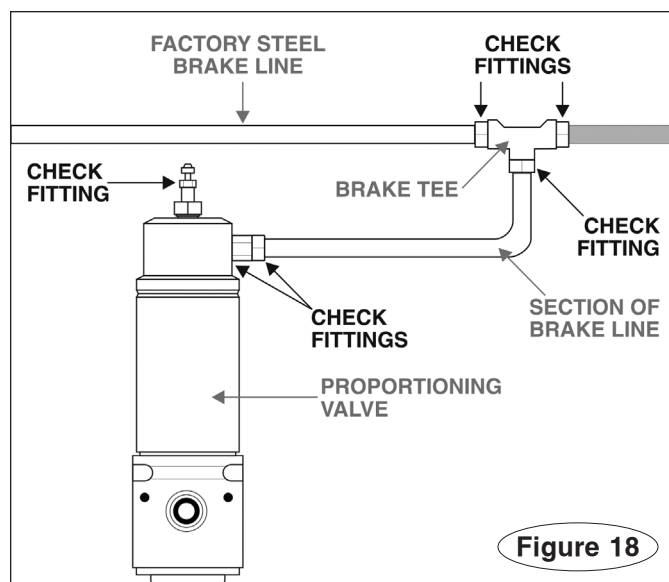

brake lines again. Do not drive the motorhome until the brake pedal provides firm resistance when it is depressed.

The brakes will not function at full capacity, or may not function at all, with air in the lines. Insufficient brake pressure may result in property damage, personal injury or even death.

Traditional method

Use this method if air has been allowed into the brake lines through the master cylinder. The procedure is identical to the “Specific brake line method” above, except that all wheel cylinders, and any components connected to the hydraulic brake system, must be bled.

This method also requires an assistant, and the same tools described under “Specific brake line method.”

1. The sequence of bleeding all brake lines is determined by the location of the lines in relation to the master cylinder – in general, always bleed the brake line farthest from the master cylinder first, then the other brake line in the same half of the circuit just bled:

If you know that the brake system is split front to rear, as is the case with many rear wheel drive vehicles, the sequence is as follows:

1. right rear
2. left rear
3. right front
4. left front

If you know that the brake system is split diagonally, as is the case with many smaller front wheel drive vehicles, the sequence is as follows:

1. right rear
2. left front
3. left rear
4. right front

2. Follow the procedures under steps 1 through 12 under “Specific brake line method” (above) for all wheel cylinders, and any components connected to the hydraulic brake system.

One-person methods

There are a number of commercially-available products which allow one person to bleed the brake lines. They use two general methods – vacuum bleeding and pressurized bleeding.

Vacuum bleeding systems use a vacuum to draw the air out of the brake system, eliminating the need for an assistant. Typically, a tube runs from the bleeder valve to a sealed container. Another tube runs from the container to a hand-held pump.

When the bleeder valve is opened, the pump draws the brake fluid and air bubbles out of the brake line and into the container.

If you use this method, follow the same sequence

continued on next page

Bleed the brakes

continued from previous page

of wheel cylinders as described in the traditional method.

Pressurized bleeding systems are used by many professional mechanics. These systems attach to the top of the master cylinder reservoir and pressurize the hydraulic fluid in the brake lines, eliminating the need for an assistant.

Wire the proportioning valve

The solenoid valve (Figure 16) on the proportioning valve allows air to pass into the BrakeMaster system each time the motorhome's brake pedal is depressed. The solenoid valve will allow air to pass only when it receives an electrical signal from the motorhome brake light system.

Where you connect the solenoid valve to the motorhome depends upon the type of brake light system in the motorhome. Compare the motorhome's brake and turn lights to Figures 19 and 20.

1. If the motorhome has a separate brake and turn signal system (Figure 19), connect the remaining black wire extending from the solenoid valve to the motorhome's brake light wire. The brake light wire can usually be located in the wiring harness that runs along the frame; the connection can be made at any convenient point.

Refer to page three for a wiring schematic.

2. If the motorhome has a combined brake and turn signal system (Figure 20), attach the included butt connector to the end of the remaining wire extending from the solenoid valve, and attach the length of included wire to the other end of the butt connector.

Route the wire from the solenoid valve to the brake light wire, under the dashboard of the motorhome. With a test light, find the "cold" side of the brake light switch – the "cold" side of the switch does not register voltage unless the brakes are applied. With a 12-volt meter, verify that you have found 12 VDC+.

Cut the brake light wire, a few inches downstream from the "cold" side of the brake light switch. Cut the wire from the solenoid valve to length, then attach it to the brake light wire with another butt connector.

Refer to page three for a wiring schematic.

Ensure that the wire will not present an obstacle or hazard to the motorhome driver, or interfere with the operation of the vehicle. Use one or more of the included wire ties, if necessary, to secure the wire out of the way.

Note: connect the wire from the solenoid valve to the brake light wire before the turn signal switch (located in the steering column). If the wire is connected after the turn signal switch, BrakeMaster will not function properly.

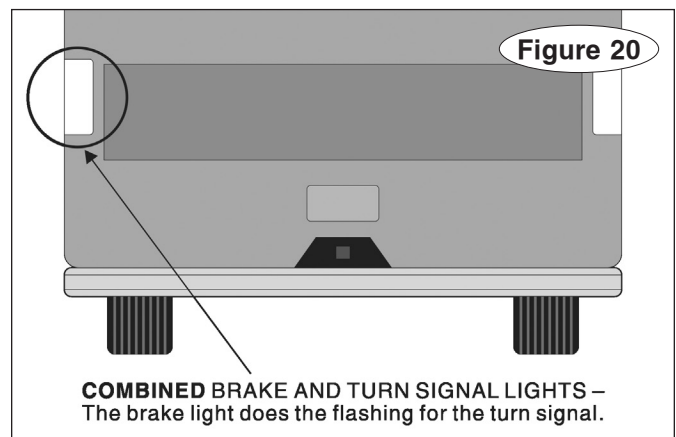
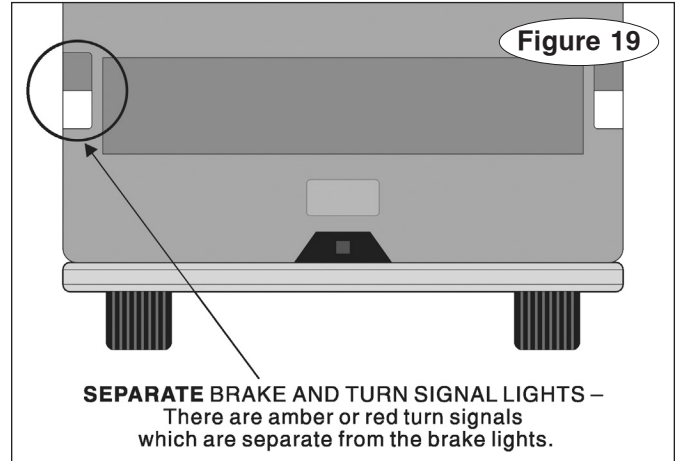

Install air lines in the motorhome

1. Route the remaining length of air line from the “in” compression fitting on the air compressor (Figure 9) to the “in” compression fitting on the proportioning valve (Figure 15).

As before, tape the ends of the air line and avoid moving parts, sharp edges or “hot” components such as the engine or the exhaust system. Do not kink the air line, or bend it to the extent that it crimps or creases.

CAUTION

Do not position the air line closer than two feet from any heat source. The heat will soften the nylon, which will cause the air line to rupture.

If the air line is ruptured, the supplemental braking system will not function.

Do not kink the air line, or bend it to the extent that it crimps or creases – air pressure will be substantially reduced, or blocked entirely, at the kink in the line.

If the air pressure is reduced, the supplemental braking system will not function, or may only function intermittently.

Where appropriate, use one or more of the included wire ties to secure the air line in place.

Trim the air line to length and connect it to the “in” compression fitting on the air compressor, and to the “in” compression fitting on the proportioning valve. Use the same method described in step 3 under “Install air lines in the towed vehicle.”

Note: if the air line is connected to the “out” compression fitting on the proportioning valve, no air can pass through the valve, and the BrakeMaster system will not function.

2. With the air lines attached, position the air compressor over the four pilot holes you drilled earlier, and use the self-tapping screws to secure the compressor in place.

3. Next, route the remaining length of air line from the “out” compression fitting on the solenoid valve (Figure 16) to the female quick coupler attached in step 13 under “Install air lines in the towed vehicle.”

As described above, tape the ends of the air line and avoid damaging the line as you route it.

Trim the air line to length and connect it to both compression fittings. Use the same method described in step 3 under “Install air lines in the towed vehicle.”

4. Check to make certain that the handle on the air tank drain valve (Figure 21) is closed.

CAUTION

The handle on the air tank drain valve should only be opened to drain the air tank. If the handle is open during towing, the air compressor will run constantly, which may damage the compressor.

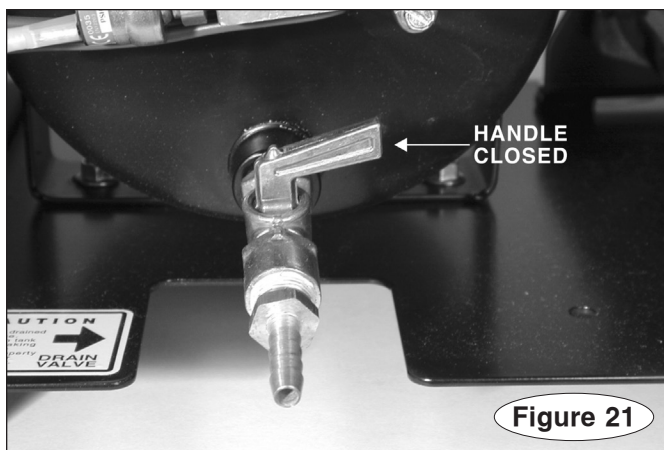

Figure 21

Install the motorhome monitor system

Step A Wire the towed vehicle

Note: there are two lengths of black wire in this kit, each with a female bullet connector at one end. Use the short length of wire in this step.

1. Choose a mounting point at the front of the vehicle, near the male quick coupler you attached in step 2, "Install air lines in the towed vehicle," for the end of the harness with the female bullet connector. Attach the connector with one or more of the included wire ties. Allow enough slack so that a male bullet connector can be plugged into and out of it.

2. Once the female bullet connector is attached, route the monitor wiring harness through the engine compartment, to the driver's side of the firewall. Use the same route as the air line, if that is convenient. As before, avoid lines, hoses, moving parts or "hot" components such as the engine or exhaust systems. Where appropriate, use wire ties to secure the wiring harness in place.

3. Route the monitor wiring harness through the same hole as the air line.

4. Before connecting the monitor wiring harness to the brake light wire, determine if the optional Brake-Lite Relay must be installed – refer to "Brake light solutions," in these instructions, for information on how to identify the type of brake and turn signals in the vehicle. Then, test the towed vehicle's brake lights, as described in "Brake light solutions."

Several wiring alternatives are available to you, based on the type of brake and turn signals in the vehicle, and the results of the test.

5. Next, locate the towed vehicle's brake light switch and, with a test light, find the "cold" side of the brake light switch. (The "cold" side of the switch does not register voltage unless the brakes are applied.) With a 12-volt meter, verify that you have found 12 VDC+.

Then, remove the vehicle's brake light fuse, located in the vehicle's fuse panel.

CAUTION

Failure to remove the brake light fuse from the vehicle's fuse panel may cause the vehicle's theft deterrent system, or other electrical system indicators, to be activated if the brake pedal is depressed during the installation. This may require non-warranty repair to the vehicle.

6. Cut the brake light wire, a few inches downstream from the "cold" side of the brake light switch.

If the Brake-Lite Relay is required... (see step 4, above)

Install the Brake-Lite Relay now. The instructions are included with the kit. After the Brake-Lite Relay is installed, proceed to Step B, "Wire the motorhome" (below).

If the Brake-Lite Relay is not required... (see step 4, above)

7. If necessary, trim the monitor wiring harness, then attach the monitor wire to the brake light wire, using the supplied yellow butt connector.

8. Ensure that the monitor wiring harness will not present an obstacle or hazard to the driver of the vehicle, or interfere with the operation of the vehicle. Use one or more wire ties, if necessary, to secure the wiring harness out of the way.

9. Reinstall the brake light fuse, which you removed in step 5.

Step B Wire the motorhome

Note: there are two lengths of black wire in this kit, each with a female bullet connector at one end. Use the long length of wire in this step.

Note: some motorhomes are manufactured with auxiliary wires pre-strung from the rear of the motorhome to the dashboard, for aftermarket accessories such as this. Call the manufacturer.

1. Attach the end of the black wire with the female bullet connector to the back of the motorhome, near the female quick coupler you attached in step 13, "Install air lines in the towed vehicle."

Attach the connector with one or more of the included wire ties. Allow enough slack so that a male bullet connector can be plugged into and out of it.

2. Once the female bullet connector is attached, route the wire from the back of the motorhome to the underside of the dashboard. Avoid lines, hoses, moving parts (slideouts, sliding generators, sliding battery trays) or "hot" components such as exhaust systems. Where appropriate, use wire ties to secure the wire to the undercarriage.

Step C Attach the LED

1. Choose an area on the motorhome dashboard to mount the LED. Look for a mounting point away from pre-existing wires or components, where the LED can be easily seen by the driver.

2. Drill a 5/16" hole through the dashboard at the point you have chosen. Before drilling, make certain you will not damage any components on the other side.

3. Center the LED decal (Figure 22) over the hole, and press it down. Or, you may choose to omit the decal, depending on your preferences.

4. From the top of the dashboard, slide the LED through the hole, wires first, until the base of the bulb (Figure 22) is flush to the top of the dash.

5. From the underside of the dash, fit both of the wires through the speed nut (Figure 22). Then push the

continued on next page

Install the motorhome monitor system

continued from preceding page

speed nut up, against the dash, to secure the LED in place.

6. Connect to power – trim the black wire, which you routed from the back of the motorhome. (Save the excess; you may use it in the next step.) Then, connect the black wire to the red LED wire, using one of the included butt connectors.

7. Connect to ground – Connect the ground wire from the LED to any good chassis ground, using the included ring terminal. (If necessary, use any excess wire from the preceding step to extend the length of the ground wire.)

Step D

Connect the patch cord between the motorhome and the towed vehicle

Note: the patch cord is the six-foot length of air line and wiring, covered in blue plastic loom.

1. Connect the male and female quick couplers at either end of the air line to the corresponding quick couplers on the motorhome and towed vehicle.

Push the couplers together until the housing (Figures 7 and 8) on the female coupler slides forward and ‘clicks,’ locking the couplers together.

(To disconnect the couplers, pull back on the housing on the female coupler until the couplers release.)

CAUTION

Never pull back on the housing to connect the couplers – this will prevent the couplers from locking. The couplers may disconnect during towing, preventing the supplemental braking system from functioning.

2. Connect the male bullet connectors at either end of the monitor wire to the female bullet connectors on the motorhome and towed vehicle monitor wiring harnesses.

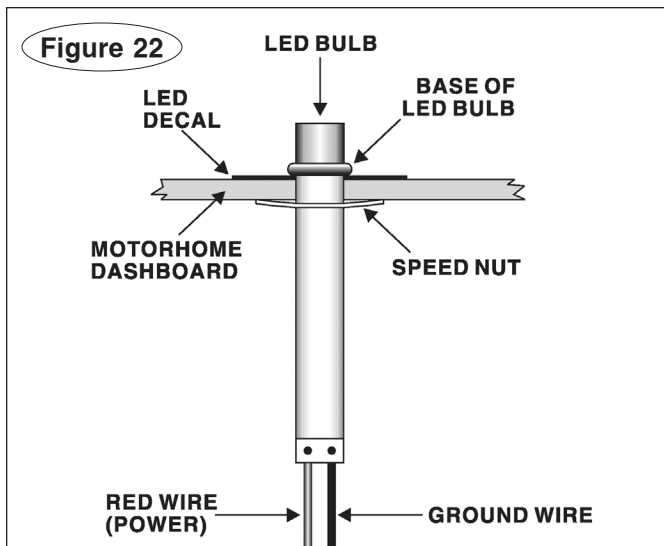

Final connections and system test

Step A

Connect the air compressor to power

1. Now that all components are installed, connect the air compressor to power – connect the red wire (positive terminal) and black wire (negative terminal) which you routed from the air compressor to the motorhome's starting battery. (Refer to steps 5 and 6 under "Wire the air compressor.")

2. Attach the blue wire which you routed from the air compressor to the ignition (switched) power source you selected in step 7 under "Wire the air compressor" – use the ring terminal at the end of the short length of wire with the fuse holder and 10-amp fuse.

Step B

Test the system

CAUTION

Always deplete the stored vacuum in the towed vehicle's power brake system before towing – pump the brake pedal several times.

Depending on the make and model of the towed vehicle, it may be necessary to pump the brake pedal repeatedly to deplete the vacuum.

If the vacuum is not released, the supplemental braking system will apply excessive braking force when it is activated, which will cause severe tire and/or brake system damage to the towed vehicle.

1. The motorhome and towed vehicle must be stationary for the system test, and ready for towing.

A. All components of the braking system must be properly connected –

- Connect and attach the tow bar to both vehicles.
- According to the manufacturer, make all adjustments necessary to prepare the vehicle for towing.

These adjustments may include: turning the ignition key to the 'tow' position; pulling fuses; disconnecting the battery; and setting the transmission to a particular gear or in a particular sequence.

Refer to the owner's manual or call the dealership for vehicle-specific information.

CAUTION

To prevent the towed vehicle from rolling, connect and attach the tow bar to both vehicles before shifting the towed vehicle's transmission into the proper gear for towing.

• Connect the patch cord between the two vehicles – both the air line quick couplers and the motorhome monitor bullet connectors.

• Attach the air cylinder to the brake pedal and seat adapter bracket (or universal anchor plate) – the installation instructions for both the adapter brackets and the

universal anchor plate are contained in their respective kits. Connect the male quick coupler at the end of the air line on the air cylinder to the female quick coupler at the end of the air line mounted in the passenger compartment.

• Clip one end of the steel break away cable to the break away pin (Figure 1); clip the other end of the cable to the rear of the motorhome, close to the center.

B. Turn the motorhome engine on, and leave it running. Turn the towed vehicle's ignition key to the "tow" position.

2. Check for leaks in the air system: allow the air compressor to run until it shuts off (approximately 45 seconds). Then, apply the motorhome brakes and continue to hold the brake pedal down.

Cover each joint, fitting and connection in the air system (including the proportioning valve – Figure 18) with a leak check solution.

CAUTION

The air system now contains pressurized air, which may cause severe eye or ear injury if it is inadvertently released. Wear appropriate eye and ear protection before adjusting the air system connections and fittings.

Tighten any fittings, if necessary, and repeat until all connections are airtight.

3. Confirm the proper operation of the braking system: depress and hold the motorhome brake pedal down. At the towed vehicle, the air cylinder shaft and pedal clamp will extend. Then, release the brake pedal. The air cylinder shaft and pedal clamp will retract.

4. Confirm that the motorhome monitor is functioning: the LED will illuminate after the motorhome brake pedal is depressed, and stop illuminating when the brake pedal is released.

WARNING

If the LED does not illuminate, as described above, identify and correct the cause of the malfunction before using the supplemental braking system. Refer to the Troubleshooting section for possible causes.

The LED is the only indication of braking activity at the motorhome. Severe damage to the towed vehicle, a loss of vehicular control or other consequential, non-warranty damage can occur if the driver of the motorhome is unaware that the supplemental braking system is not functioning properly.

5. Confirm the proper operation of the break away system –

Charge the break away air reservoir – start the motorhome and allow the air compressor to run until it

continued on next page

Final connections and system test

continued from preceding page

shuts off. Then, apply the motorhome brakes and hold the brake pedal down.

WARNING

The break away air reservoir must be charged, as described above, every time the motorhome and towed vehicle are connected. If the air reservoir is not charged, the break away system will not apply braking pressure if the towed vehicle separates from the motorhome, which may cause property damage, personal injury or even death.

Next, remove the break away pin (Figure 1) at the front of the break away switch. The air cylinder and pedal clamp will extend, confirming the proper operation of the break away system.

To retract the air cylinder and pedal clamp, briefly disconnect the quick couplers from the air line extending from the air cylinder. Then, reconnect the break away pin.

Before towing, charge the break away air reservoir, as described above.

6. Confirm the proper operation of the towed vehicle's brake lights and turn signals –

A. Depress the motorhome brake pedal; confirm that the towed vehicle's brake lights illuminate. Activate both of the motorhome turn signals; confirm that the towed vehicle's turn signals activate.

If the towed vehicle's brake lights and turn signals do not operate in tandem with the motorhome's, you must install a non-intrusive lighting system or re-wire the towed vehicle. See "Brake light solutions."

B. With one of the motorhome turn signals activated, depress the motorhome brake pedal. Confirm that the towed vehicle's brake lights and turn signal both illuminate.

If the towed vehicle's brake lights override the turn signal, you must install a non-intrusive lighting system or re-wire the towed vehicle. See "Brake light solutions."

WARNING

By law, a towed vehicle's turn signals and brake lights must operate in tandem with the motorhome's, as described above. If they do not, drivers behind the towed vehicle will not be alerted when the motorhome stops or turns, which may cause an accident.

If the towed vehicle's brake lights and turn signals do not operate in tandem with the motorhome's, either install a non-intrusive lighting system or re-wire the towed vehicle according to the next section, "Brake light solutions." Then, test for proper operation, as described in step 6, above.

Brake light solutions

A supplemental braking system will affect the operation of the vehicle's tow lighting system. Use the information below to determine if optional components must be installed in a vehicle which has been wired for towing – or, if no lighting system has been installed, which systems are appropriate.

1. First, identify the type of brake and turn signals in the vehicle. There are two types – combined or separate. In a **combined** system (Figure 23), the brake light does the flashing for the turn signal; in a **separate** system (Figure 23), there are amber or red turn signal lights which are separate from the brake lights.

2. Next, test to see if the towed vehicle's brake lights will illuminate with the engine off – with the ignition key at the "tow" position, press the brake pedal and check the brake lights.

3. Based on whether or not the brake lights illuminate, and the type of brake and turn signals, there are three possibilities:

- the brake lights illuminate and the towed vehicle has combined lighting;
- the brake lights illuminate and the towed vehicle has separate lighting; or
- the brake lights do not illuminate.

There are a number of lighting methods available for each of these three possibilities; they are described below.

(If you choose to install a Universal Wiring Kit, a Taillight Wiring Kit, magnetic tow lights or the Brake-Lite Relay, complete installation instructions and wiring diagrams are included with the kits; this information is also available online at www.roadmasterinc.com.)

If the brake lights illuminate and the towed vehicle has combined lighting...

...one of the three alternatives below is required:

- A Universal Wiring Kit (part number 154) **with** a Brake-Lite Relay – a system of diodes is installed to rewire the vehicle's turn signals, taillights and brake

lights for towing.

- Install an optional "bulb and socket set" (also called a "taillight wiring kit," part number 155).
- Install an optional magnetic tow light system (part number 2100 or 2120).

If the brake lights illuminate and the towed vehicle has separate lighting...

...one of the four alternatives below is required:

- A Universal Wiring Kit (part number 154) **with** a Brake-Lite Relay – a system of diodes is installed to rewire the vehicle's turn signals, taillights and brake lights for towing.
- Install six diodes, and jump the diodes. See page 26.
- Install an optional "bulb and socket set" (also called a "taillight wiring kit," part number 155).
- Install an optional magnetic tow light system (part number 2100 or 2120).

If the brake lights do not illuminate...

...an optional stop light switch **must** be installed. Stop light switch kits for many vehicles are available through ROADMASTER; visit www.roadmasterinc.com for the most current list.

Any one of the following tow lighting systems must also be installed with the stop light switch:

- A Universal Wiring Kit (part number 154) – a system of diodes is installed to rewire the vehicle's turn signals, taillights and brake lights for towing.
- An optional "bulb and socket set" (also called a "taillight wiring kit," part number 155)
- An optional magnetic tow light system (part number 2100 or 2120)

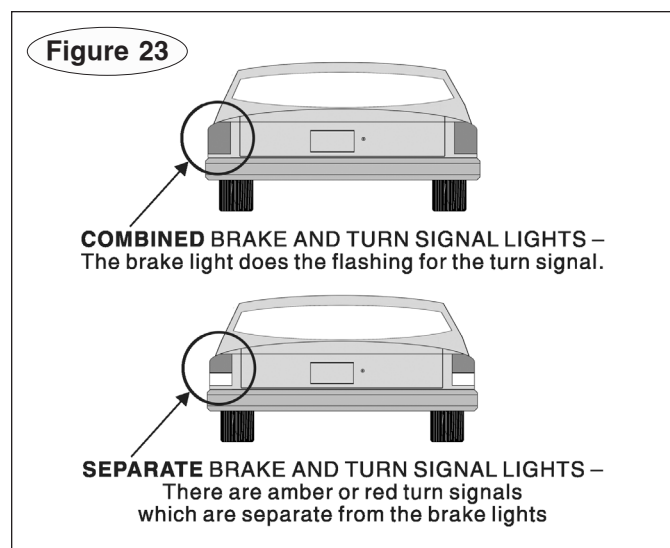

Install six diodes

Note: this wiring method can only be used if the brake lights illuminate with the engine off and the towed vehicle has separate lighting. See page 25.

Note: if the motorhome has combined brake and turn signals, use Figure 24 to wire the towed vehicle. If the motorhome has separate brake and turn signals, visit www.roadmasterinc.com. Use the 'Separate towed vehicle to separate motorhome' wiring diagram under 'Support.'

Note: if a 3-to-2 converter has been installed in a motorhome with separate brake and turn signals, wire the towed vehicle according to Figure 24.

To test for a 3-to-2 converter, use a test light to find the turn signal and brake light circuits on the motorhome electrical socket. If the same circuit energizes both the turn signals and the brake lights, a 3-to-2 converter has been installed. If the turn signal and brake lights have separate circuits, a 3-to-2 converter has not been installed.

1. Cut the factory turn signal, taillight and brake light wires, as close to the lights as possible.
2. Install the six diodes in line, as shown in Figure 24. Install the diodes as close to the lights as possible.

CAUTION

Attach the diodes as close to the vehicle's

lights as possible, to avoid interaction with other circuits which may be tied into the center brake light, the running lights, the turn signals or the brake light wires.

Attaching the diodes farther away may cause the towed vehicle's lights to work improperly and may also cause damage to other electrical components in the vehicle.

3. On each side, jump the brake and turn signal diodes, as shown in Figure 24.

CAUTION

Unless the brake and turn signal diodes are jumped, the towed vehicle's brake light circuits will override the motorhome's turn signals – the towed vehicle's turn signals will not operate in conjunction with the motorhome's turn signals, as required by law.

4. Test the installation...
 - A. If the motorhome has a combined lighting system (Figure 23)...
 1. The towed vehicle's turn signals and brake lights will both flash (each side) when the motorhome's
- continued on next page*

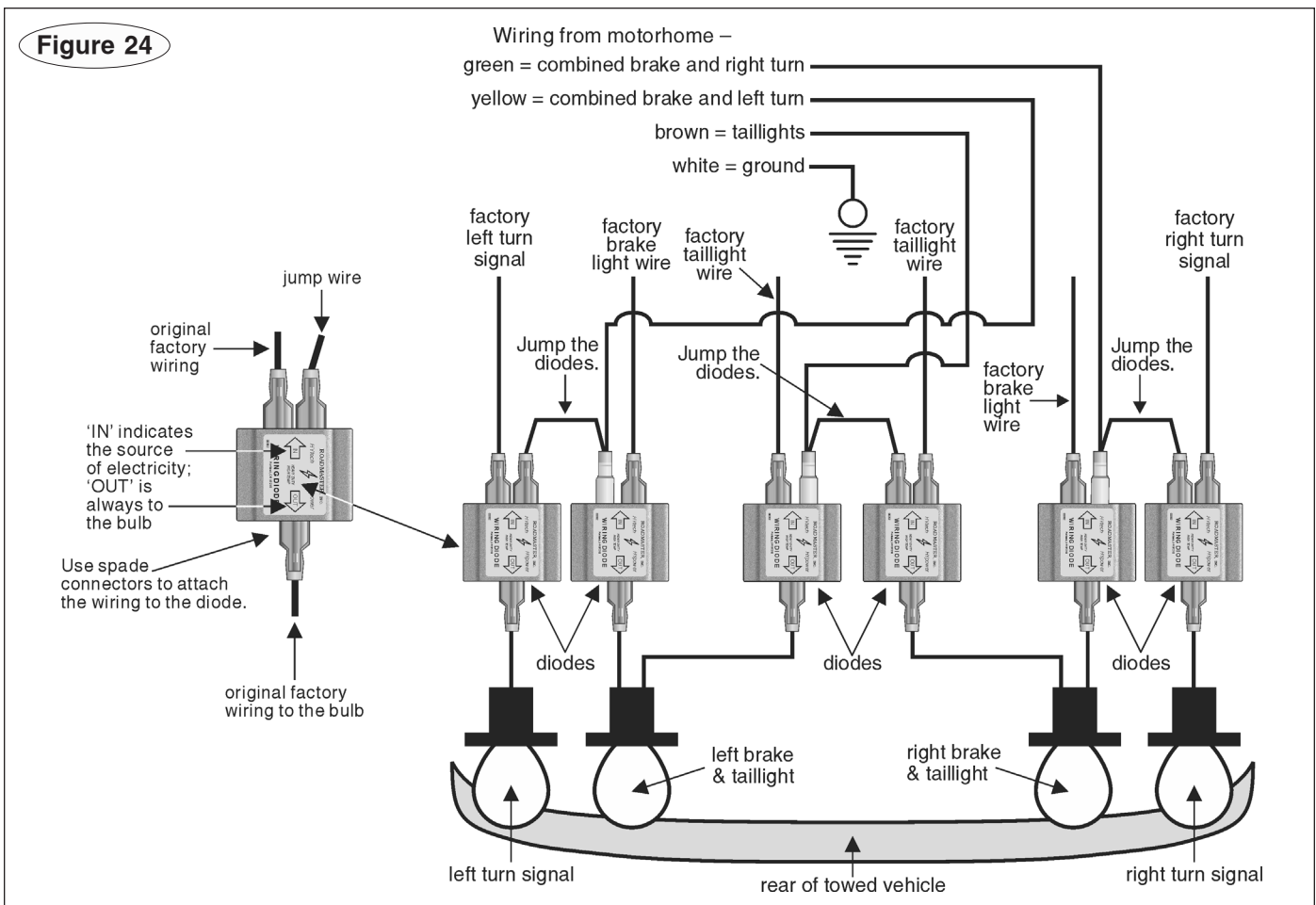

Install six diodes

continued from preceding page

turn signal is on; and

2. When the motorhome's turn signal and brake signal are both on (each side), the towed vehicle's brake lights will stay illuminated, while the turn signal flashes.

B. If the motorhome has a separate lighting system (Figure 23), the towed vehicle's turn signals and brake lights will illuminate identically to the motorhome's.

Troubleshooting

Symptom

The motorhome monitor LED does not illuminate, even though the brakes in the towed vehicle are being applied.

Solution

1. The monitor LED will not illuminate during very light braking.
2. Make certain that the monitor patch cord is securely connected between the two vehicles.
3. The towed vehicle-to-motorhome electrical cord must also be connected – the monitor system uses it for the ground wire.
4. The monitor LED is connected to the towed vehicle's brake light circuit. If the fuse in the circuit is blown, the LED will not illuminate. Check the towed vehicle's brake lights – if they illuminate when the brake pedal is depressed, the fuse is good.
5. Did you install the optional Brake-Lite Relay? If so, make certain that the monitor wire is connected to the towed vehicle's brake light wire **after** the brake light switch, but **before** the Brake-Lite Relay – connecting the wire anywhere else will prevent the monitor LED from functioning.

Symptom

Nothing happens after proper installation.

Solution

1. The motorhome engine must be running – if the engine is off, there may be insufficient hydraulic pressure to activate BrakeMaster.
2. Check the air line connections. Remove the weather covers from the quick couplers at both vehicles, and gently tug on the air line to verify that the quick couplers are connected.
Check to make certain that the air cylinder quick coupler is connected to the air line in the passenger compartment.
3. Check the wiring at the solenoid valve (on the proportioning valve). One of the black wires must be connected to a good chassis ground (Figure 16). The other black wire must be connected to the motorhome brake wire downstream from the brake light switch (Refer to "Wire the proportioning valve."). Use a test light to confirm that the solenoid valve is receiving power when the motorhome brake pedal is depressed.

If the connections are good, test for proper function – with the motorhome engine running, have an assistant depress the motorhome brake pedal while you listen for a "click" at the solenoid valve. The solenoid valve should "click" every time the brake pedal is depressed.

4. Disconnect the air line from the "out" compression fitting on the solenoid valve (Figure 16). Have an assistant depress the motorhome brake pedal – the proportioning valve should release air each time the pedal is depressed.
- A.** If there is air at the proportioning valve – follow the

air line back to the air cylinder in the towed vehicle. Inspect the entire line for deformities caused by excessive heat and/or kinks in the line, which would restrict the air flow – replace the entire section of air line if any are found.

Disconnect the quick couplers to confirm that they are allowing air to flow through them.

B. If there is no air at the proportioning valve – check to confirm that the air line between the air compressor and the proportioning valve is connected to the correct fitting. It should run from the "in" fitting on the air compressor (Figure 9) to the "in" fitting on the proportioning valve (Figure 15).

If the air line is connected to the "out" fitting on the proportioning valve, no air can pass through the valve, and the BrakeMaster system will not function.

If this is the case, reconnect the line from the air compressor to the "in" fitting in the proportioning valve.

Symptom

The compressor runs constantly, or runs much more frequently than I think it should.

Solution

1. Check for leaks in the air system.
2. Make certain that the drain valve on the air compressor air tank is closed. Refer to Figure 21.
3. Make certain that the drain valve on the BreakAway air reservoir is closed. Refer to Figure 1.
4. Make certain that a female quick coupler has been installed at the rear of the motorhome – a male quick coupler does not have a check valve to prevent air from escaping.

Symptom

It seems to require a significant amount of brake pressure in the motorhome before the BrakeMaster air cylinder activates in the towed vehicle.

Solution

1. The motorhome engine must be running – if the engine is off, there may be insufficient hydraulic pressure to activate BrakeMaster.
2. Inspect the air lines for deformities caused by excessive heat, and/or kinks in the line, which would restrict the air flow – replace the entire section of air line if any are found.
3. Check for leaks in the air system: after starting the motorhome, allow the air system to fully charge. Depress and hold the motorhome brake pedal down.

Cover each joint, fitting and connection in the air system with a leak check solution.

Tighten any fittings, if necessary, and repeat until all connections are airtight.

4. If the towing vehicle is a Ford Class C motorhome, the proportioning valve must be teed into the front hydraulic brake line – the rear brake line does not sup-

continued on next page

Troubleshooting

continued from preceding page

ply sufficient hydraulic pressure.

5. Not all of the air was bled from the brakes after installing the proportioning valve. Re-bleed the proportioning valve, as well as all brakes (and any components connected to the brake system) downstream from the brake tee.

Symptom

The BrakeMaster air cylinder will extend and depress the towed vehicle's brake pedal. However, it will not retract when the motorhome brake pedal is released.

Solution

1. Make certain that the air cylinder has been installed directly in line with the brake pedal. If it is mounted at an angle to the brake pedal (to one side or the other), the air cylinder may jam in the extended position.

2. Dirt or debris can enter the air lines if the weather covers are not used over the quick couplers. It may accumulate at the quick exhaust valve (see page four) on the air cylinder, preventing the valve from venting air out of the air cylinder. Disassemble the quick exhaust valve and make certain it is not jammed.

3. If a system of diodes was used to wire the towed vehicle's lights for towing, make certain that a diode is installed at every point where the motorhome brake light wire connects to the towed vehicle's brake light wire. (Refer to Figure 24.)

When the air cylinder extends and depresses the towed vehicle's brake pedal, it energizes the towed vehicle's brake light wire. If diodes are not installed in the circuit, current will travel back to the motorhome and activate the BrakeMaster solenoid.

As long as the solenoid is activated, it will not allow air to vent from the air cylinder – the air cylinder will remain extended.

Symptom

The towed vehicle brakes abruptly the first time BrakeMaster is activated, 'flat-spotting' the tires. Also, after towing, there may be excessive brake dust on the wheels of the towed vehicle and/or an unusual odor near the towed vehicle's brakes.

Solution

1. The stored vacuum in the towed vehicle's power brake system **must** be depleted before towing – pump the brake pedal several times. Depending on the make and model of the towed vehicle, it may be necessary to pump the brake pedal repeatedly.

Deplete the vacuum in the power brakes every time the towed vehicle's engine has been started – typically, when the vehicle is connected for towing.

The engines in some vehicles, such as the Saturn Vue, must be started periodically during towing. If the towed vehicle's engine must be started periodically, always deplete the vacuum in the vehicle's power

brake system **before** you resume towing.

Refer to the caution statement on page 23.

2. If the towed vehicle has an 'active' (or, 'continuous power assist') braking system, order the optional Brake Pressure Reducer (part number 900002) to adapt the vehicle to the BrakeMaster system.

Vehicles with 'active' brake systems include several hybrid vehicles, such as the Ford Escape hybrid and the Mercury Mariner hybrid, as well as the H3 Hummer. These vehicles, and others with 'active' braking systems, are designed so that even when the ignition is turned to the 'tow' position, the braking system is still active.

If the Brake Pressure Reducer is not installed, BrakeMaster will apply excessive force to the towed vehicle's brake pedal.

3. If the towed vehicle does not have power brakes, order the optional Brake Pressure Reducer (part number 900002) to adapt the vehicle to the BrakeMaster system.

BrakeMaster is designed to work with vehicles that have a power brake system (even though the power brakes are not activated while towing).

If the reducer is not installed, BrakeMaster will apply excessive force to the towed vehicle's brake pedal.

Index

'Active' braking systems	2	Safety definitions	1
Air compressor		Separate brake and turn signal	
Choosing a mounting location.....	10	lights – definition (Figure 23)	25
Terminal block wiring.....	10-11	Solenoid valve	
Air cylinder		Connecting to motorhome	19
Parts list	4	Grounding.....	14
Air lines		System test.....	23-24
Checking for leaks in the system.....	23	Taillight wiring system	25
Connecting to compression fittings.....	8	Vacuum, power brakes –	
Air tank drain valve – cautionary statement.....	20	cautionary statement.....	23
Bleeding the brakes		Wiring diagrams.....	3
One-person methods.....	17-18		
Specific brake line method.....	16-17		
Traditional method.....	17		
Brake lights, towed vehicle			
Testing for proper operation	24		
Wiring methods	25		
Brake light switch – test to find			
“cold” side	19, 21		
Brake power booster –			
removing residual vacuum from	13		
Break away system			
Connecting the break away cable.....	23		
Air reservoir – choosing a mounting location	5		
Initial installation.....	5-7		
Testing	23-24		
Combined brake and turn signal			
lights – definition (Figure 23)	25		
Compression fittings – connecting air lines to.....	8		
Couplers, connecting and disconnecting	22		
Flair adapter	16		
Ford Class C motorhome –			
mounting location for proportioning valve	15		
Fuses			
Removing from towed vehicle			
prior to installation.....	2		
Removing brake light fuse			
during motorhome monitor installation.....	21		
LED, motorhome monitor			
Attaching during initial installation	21-22		
Proper function.....	23		
Warning statement	23		
Magnetic tow lights.....	25		
Motorhome monitor – initial installation	21-22		
Patch cord – connecting between			
motorhome and towed vehicle	22		
Power brakes – releasing vacuum –			
cautionary statement.....	23		
Proportioning valve			
Bleeding the proportioning valve.....	15		
Fittings to check after bleeding			
the brakes (Figure 18).....	17		
Choosing a mounting location.....	12		
Initial installation.....	12-15		
Rotating port for connection to brake line.....	15		
Wiring	19		
Quick couplers, connecting and disconnecting.....	22		

— ADVERTISEMENT —

Towed vehicle protection

Protect your towed vehicle's finish, headlights and windshield against damage with these two ROADMASTER products!



Made in the U.S.A.



Protect your towed vehicle and RV against dings and rock chips!

The Guardian is crafted from rotationally-molded, high-impact polyethylene to absorb the impact of rocks, gravel and road debris – instead of ricocheting it back at the motorhome.

The Guardian can be attached and removed in seconds, and fits all ROADMASTER tow bars equipped with quick-disconnects. (Note: MX, MS or EZ5 brackets will not accommodate the Guardian.)

The Guardian can also be used with a tow dolly to help protect your towed vehicle by using the Guardian bracket (part number 2000-8).

If you tow more than one vehicle, the second vehicle kit has all the mounting hardware necessary to swap the Guardian from one vehicle to another.



pictured:
4700 Tow Defender

U.S. patent number
8,708,369



A bumper-to-bumper blanket of protection!

The Tow Defender's all-weather, heavy-duty screen deflects rocks, gravel and road debris down and away, protecting your towed vehicle's finish, headlights and windshield against chips and dings. The vinyl-coated mesh lets air through, keeping it low and over the road.

Fully extended, both Tow Defenders offer 20 square feet of protection, and are held in place with shock-absorbing gas struts. Once you've reached your destination, roll up the Tow Defender, snap the elastic straps around each end, and store it against the motorhome.

- Quick installation and release
- Lightweight and compact – weighs just 14.5 pounds, and rolls up to four inches in diameter
- Powder-coated steel supports and heavy-duty gas struts for maximum durability, support and cornering flexibility

For maximum protection, use a Tow Defender and a Guardian.

Motorhomes kick up rocks, gravel and road debris, but so does oncoming traffic. A Tow Defender/Guardian combination protects your towed vehicle's finish, headlights and windshield against damage from both lanes.

“We get your towed car there,
while stopping safely along the way.”

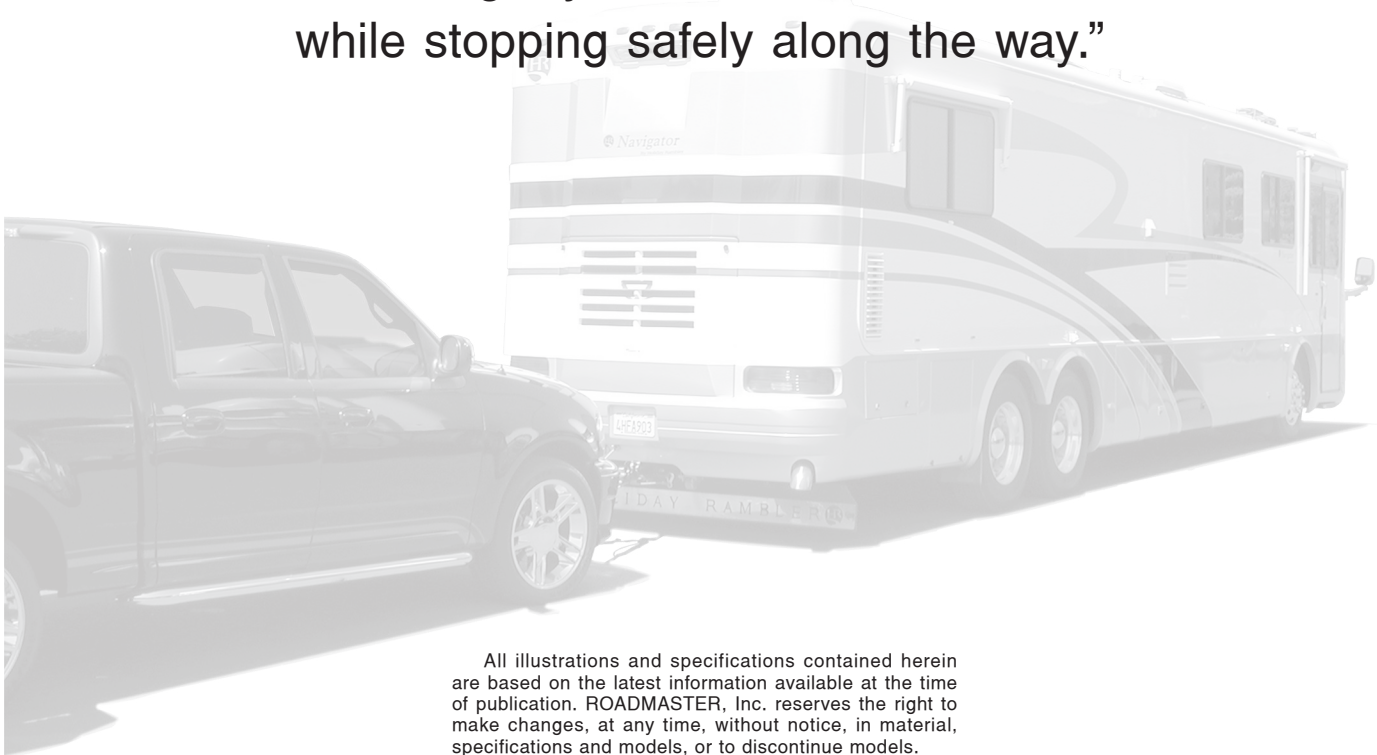

All illustrations and specifications contained herein are based on the latest information available at the time of publication. ROADMASTER, Inc. reserves the right to make changes, at any time, without notice, in material, specifications and models, or to discontinue models.



Time Tested • Time Proven

ROADMASTER, Inc. • 6110 N.E. 127th Ave. • Vancouver, WA 98682
800-669-9690 • Fax 360-735-9300 • roadmasterinc.com