



**IMPORTANT!**

**CONTENTS OF THIS  
MANUAL MUST BE  
READ BY OWNER**

*Sterling*  
by ROADMASTER

**THE FINEST TOW BAR ON THE PLANET**

*Owner's Manual*

**Congratulations** on the purchase of your new **STERLING™** tow bar...and **THANK YOU.** You have purchased the finest tow bar made...bar none! Quality materials, computer technology and our reputation for craftsmanship have gone into each of our precision folding tow bars. Each of our products is designed for safe, trouble-free towing. Your safety is important to us. This booklet was written with your safety in mind.

Before using your tow bar, read this booklet. Understand how to install & maintain your tow bar and carefully follow all the instructions and safety precautions. **Remember, proper installation and use of the product is the sole responsibility of the purchaser. Improper installation, use or maintenance may result in personal injury, property damage or even death.**

A good time to inspect your mounting brackets is during your regular vehicle maintenance check-ups such as an oil change, brake check or tire rotation. Don't forget to keep your tow bar clean and lubricated on a regular basis. We offer a silicone spray specifically for this purpose. Using our vinyl tow bar cover will help keep your tow bar free from dirt and road grime assuring easy hook-up and operation. **Safety cables are required by law in most states.** Follow our safety cable installation in this booklet.

To qualify for your Warranty you must completely fill out and return the enclosed warranty registration card within (30) thirty days of purchase. As a bonus, we'll extend your warranty to a total of two years at no additional cost. As a **STERLING** owner, rest assured you have bought the finest tow bar on the planet. We thank you for your patronage and greatly appreciate your discerning taste.

# FREE EXTENDED WARRANTY

You must fill out & mail the warranty registration card within thirty (30) days from the date of purchase to qualify for your warranty. If we receive your card within 30 days, we will extend the coverage to a total of **TWO (2) years** at no extra charge.

Your warranty registration is an important record for **ROADMASTER** to keep in touch with you. It also enables us to expedite any future claim, update or recall that may arise concerning our products.

## IMPORTANT

**FILL OUT - TEAR OFF & MAIL WITHIN 30 DAYS TO QUALIFY FOR YOUR WARRANTY AND TO RECEIVE YOUR FREE ONE YEAR EXTENSION.**

### WARRANTY PROCEDURES

If you have any problems with this product, immediately contact **ROADMASTER** at 1-800-669-9690. If necessary, we can direct you to your nearest warranty service center and make arrangements for any warranty repairs or replacements. While under warranty, **ROADMASTER** will make arrangements for your product to be repaired or replaced. **Do not purchase replacement parts or pay for labor - you will not be reimbursed.** See section titled "**ROADMASTER Limited Warranty**" for specific details.

**ROADMASTER**

**FREE BONUS**

### **CAN'T LOCATE YOUR TOW BAR SERIAL NUMBER?**

**YOUR TOW BAR SERIAL NUMBER IS ON A LABEL. YOU WILL NEED THIS NUMBER WHEN YOU FILL OUT YOUR TOW BAR WARRANTY INFORMATION.**

**RETAIN SERIAL NUMBER FOR FUTURE REFERENCE.**

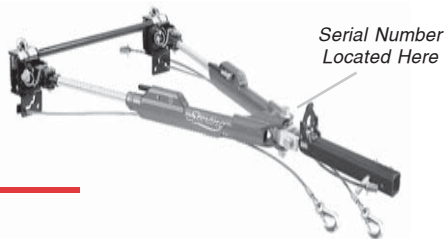

**SERIAL NUMBER # \_\_\_\_\_**

# 10 MUSTS FOR TOWING SAFETY

1. ***TOW BAR MUST BE LEVEL WITH THE MOTORHOME. DO NOT TOW IF TOW BAR IS OVER 6 INCHES OFF LEVEL IN EITHER DIRECTION***

Towing with an upward or downward slope of the tow bar puts undue strain on the tow bar and mounting brackets. Do not tow if tow bar is over 6 inches off level (see page 17).

2. ***STEERING MUST BE UNLOCKED AND FREE TO TURN WHEN TOWING***

Failure to do so can result in severe tire and equipment damage. Steering wheel must be free to turn when towing.

3. ***DRIVER MUST NOT BACK UP MOTORHOME WITH VEHICLE ATTACHED***

Backing up with towed vehicle attached easily causes the vehicle to "jack-knife" and will damage the tow bar, mounting bracket, hitch, the towed vehicle front end and/or rear of the motorhome. This is the primary cause of tow bar damage and will void the warranty.

4. ***TOW BAR MUST BE SECURED WITH LINCH PINS AND/OR PADLOCKS BEFORE TOWING***

Unless the tow bar is secured to both vehicles with all designated pins and/or padlocks, you will lose your towed vehicle.

5. ***OWNER MUST KEEP THE TOW BAR CLEAN AND WELL LUBRICATED***

As is the case with most precision equipment, frequent cleaning and care results in prolonged service. Details for cleaning & lubricating your **STERLING** tow bar are outlined in the section titled "**Care and Cleaning**" (page 18).

6. ***OWNER MUST INSPECT ALL MOUNTS, BRACKETS AND FASTENERS***

Visually inspect ALL bolts, wiring, cables and metal components each time before you tow to avoid problems on the road. Check brackets every 3,000 miles. Inspect for any fractures or cracks in the steel or any visible damage. **Do not tow if damaged.** Check torque on all bolts. Refer to installation instructions for mounting brackets and tow bar for torque ratings.

7. ***OWNER MUST FILL OUT & MAIL THE WARRANTY REGISTRATION CARD***

It is **IMPORTANT** that you send in a completely filled out registration card as soon as possible. The information is needed in case we must contact you for updates, recalls and to verify your warranty.

**8. OWNER MUST CHECK MANUFACTURER'S INSTRUCTIONS FOR TOWING**

Some vehicles require a transmission lube pump, axle disconnect, driveline disconnect or free-wheeling hubs to tow without damaging equipment. Failure to properly equip vehicle will result in severe damage to the transmission. Check manufacturer's specifications for the proper procedure to prepare vehicle for towing. Be sure your vehicle is towable before taking it on the road.

**9. OWNER MUST NEVER TOW VEHICLE WITH A LIGHTER VEHICLE**

Towing a vehicle equipped with a tow bar using a lighter weight vehicle will cause the rear vehicle to over-ride the front vehicle, resulting in "jack-knifing", "leap-frogging", "fish-tailing" or other unsafe towing situation. Serious damage to both vehicles and the towing system equipment could result.

**10. OWNER MUST ALWAYS USE SAFETY CABLES OR CHAINS WHEN TOWING**

A frame to frame safety cable hookup is legal in ALL states that require them.

**11. OWNER MUST CHECK TURNING RADIUS OF MOTORHOME BEFORE TOWING.**

Some motorhome chassis have such a tight turning radius that you can damage your motorhome, towed vehicle or tow bar while turning sharply. Before getting on the road with your towed vehicle, you should test your turning radius in an empty parking lot. With the towed vehicle attached, have someone watch you as you slowly turn sharply to see if you have this potential problem. Damage that results from turning to sharply is not covered by warranty.

**CAUTION!**

**NEVER BACK UP WHEN TOWING YOUR VEHICLE**

Backing up while the towed vehicle is attached, will easily "jackknife" the vehicle being towed. This will result in damage to the towed vehicle, hitch, tow bar assembly, and/or motorhome. **ROADMASTER, Inc** assumes no responsibility for any damage that is caused by improper use. Backing up with a towed vehicle is considered "improper use".

**FAILURE TO FOLLOW INSTRUCTIONS MAY RESULT  
IN PROPERTY DAMAGE, PERSONAL INJURY OR DEATH**

# INSTALLER *MUSTS* FOR SAFETY

The following "***Musts for Safety***" are provided to your installer with the installation instructions for the **STERLING**. It is repeated here for your information. As a precautionary measure, verify that you or the installer have followed all safety requirements before towing your vehicle.

1. ***INSTALLER MUST SHOW OWNER HOW TO PROPERLY OPERATE THE TOW BAR.***

Instruct Owner to read and follow instructions in Owner's Manual before using tow bar. Carefully read the section "Hook-up Instructions" and familiarize yourself with the features of the tow bar. Demonstrate it and have the owner do a few "practice runs". You not only impress your customer with your thoroughness, but will start your customer off on a safer and happier towing experience.

2. ***INSTALLER MUST CAUTION OWNER TO USE A HITCH OR RECEIVER FOR THE MOTORHOME THAT IS RATED HIGHER THAN THE ACTUAL WEIGHT OF YOUR VEHICLE INCLUDING ALL OF ITS CONTENTS.***

3. ***INSTALLER MUST CAUTION OWNER TO SECURE TOW BAR TO BOTH VEHICLES WITH DESIGNATED PINS AND/OR PADLOCKS.***

Unless all the pins are used to secure the tow bar to both vehicles, the owner ***will*** lose his towed vehicle.

4. ***INSTALLER MUST BOLT THE STERLING QD BASE TO A MOUNTING BRACKET ATTACHED TO THE TOWED VEHICLE'S FRAME OR UNIBODY.***

The **STERLING** tow bar is designed as a bolt-on device only. Virtually all vehicles require a mounting bracket assembly that is connected safely to the frame, unibody or chassis and extends beyond the bumper. Using a mounting bracket kit designed by **ROADMASTER** takes the burden of doubt out of the installer's hands. **Under no circumstances should the tow bar be welded to the vehicle, nor should any of the pre-punched mounting holes be altered.** In fact, any welding or altering of the tow bar will void the Owner's Warranty.

5. ***INSTALLER MUST ADVISE OWNER TO USE 6,000 LB. OR HIGHER RATED SAFETY CABLES***  
Frame to frame safety cables are legal in ALL states.
6. ***INSTALLER MUST STRESS IMPORTANCE OF OWNER SENDING IN WARRANTY CARD***  
New owners are to be urged to mail their Warranty Registration Card as soon as possible. This will enable **ROADMASTER** to expedite any claim or update important information concerning their **STERLING** tow bar.
7. ***INSTALLER MUST READ INSTRUCTIONS THOROUGHLY BEFORE MOUNTING THE TOW BAR***  
Proper mounting of the tow bar is of critical importance. Proper centering and height positioning of the tow bar will give the owner a safe, dependable and trouble-free towing system.
8. ***INSTALLER MUST BE SURE THE VEHICLE IS SUITABLE OR ADAPTABLE FOR TOWING***  
Not all vehicles can be safely towed as manufactured. A few models are not towable under any conditions and others with automatic transmissions require additional equipment such as a transmission lube pump, axle lock, driveline disconnect or free-wheeling hubs to make them towable. Failure to properly equip the towed vehicle will result in severe damage to the transmission. Also, the steering wheel **MUST** be unlocked for towing. Check manufacturer's specifications for the proper way to unlock the steering wheel.

**FAILURE TO FOLLOW INSTRUCTIONS MAY RESULT  
IN PROPERTY DAMAGE, PERSONAL INJURY OR DEATH**

# HOOK-UP INSTRUCTIONS

*Use caution when operating the tow bar to be sure that your hands, fingers or any part of your body does not get caught between any moving components. Doing so can result in pinching, crushing or cutting causing severe personal injury.*

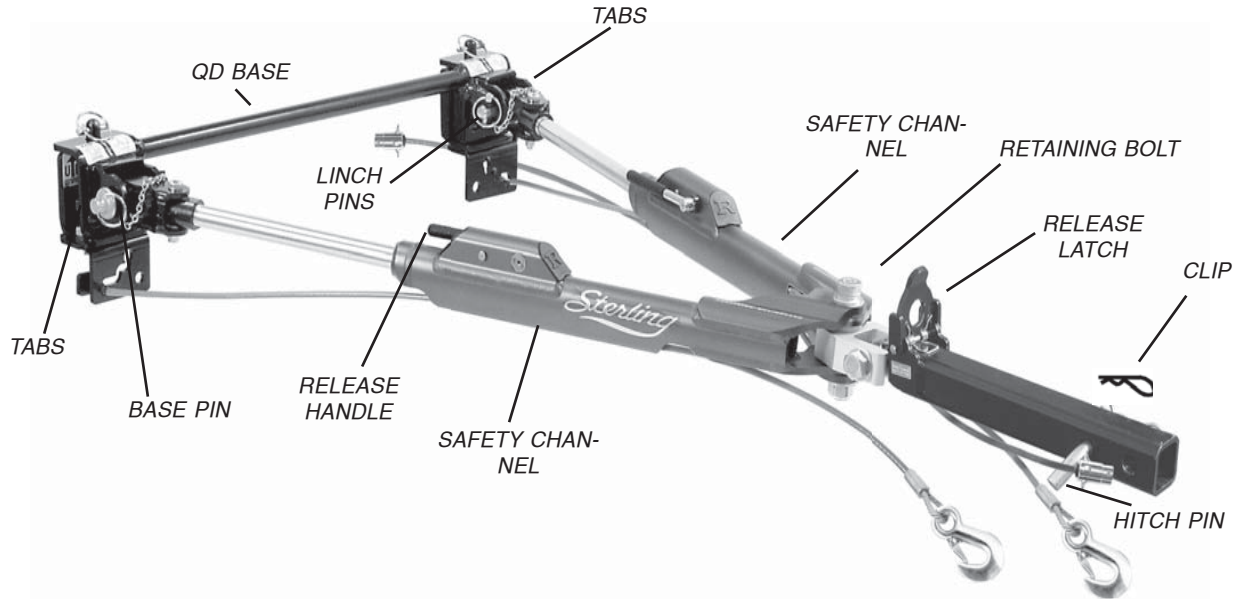
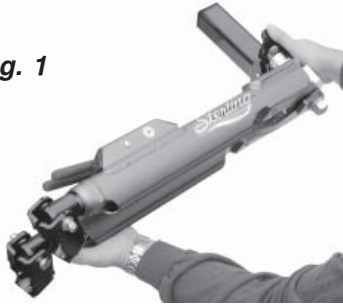



Fig. 1



**STEP 1**

Follow **Installation Instructions** (in separate envelope) to mount **STERLING Quick Disconnect Base**

**STEP 2**

With the **STERLING** tow bar in the folded position (Fig.1), insert it into the motorhome's receiver and secure with **Hitch Pin & Clip**.

**STEP 3**

Fig. 2



Firmly hold both tow bar arms and rotate them so that they are vertical as shown in Figure 2. **WARNING:** Never let go of the arms when they are in the vertical position. The arms can fall and cause severe injury **if any part of your body is in the way.**

**STEP 4**

Fig. 3



Push the Release Latch forward to bring both arms down to a horizontal position (Fig. 3). Swing both arms away from you aligning the outermost arm with the tabs on the Quick-Disconnect Base. Using the included Base pin, attach the arm and secure with linch pin or optional padlock.

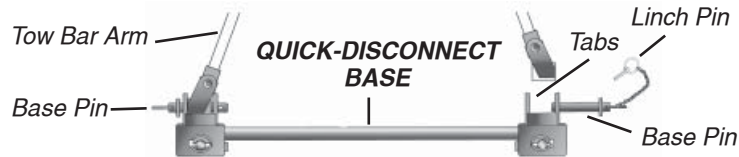

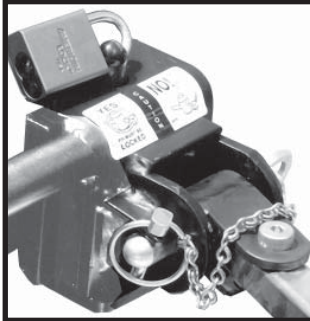

***IMPORTANT:***  
***Base Pins***  
***Must Be Installed***

and locked as shown in this photo. Failure to properly secure pins will result in loss of towed vehicle.

***STEP 5***

Now, swing the other arm to the opposite side and connect in the same manner. Before continuing make sure your vehicle is prepared for towing as per the manufacturer's instructions. In particular make sure:

- a. Your steering wheel is in the unlocked position so it can freely move
- b. The transmission is in the correct gear for towing
- c. The emergency brake is released
- d. You've connected your safety cables and wiring

***STEP 6***

Now slowly pull away in the motorhome. Your tow bar will self center and the **AUTOWLOK System** will "**SNAP**" into position as you drive away. Visually verify that the locks have engaged before taking your trip.

**TIP:** *If the **STERLING** arm does not automatically lock when you pull the motorhome ahead, try turning the motorhome left, then right as you drive away. This will pull each arm in the necessary direction to engage the locking mechanism.*

# DISCONNECT INSTRUCTIONS

To disconnect the **STERLING**:

- a. **IMPORTANT!** Set your towed vehicle's emergency brake and put your vehicle in Park when un-hooking. Otherwise the towed vehicle will roll-away when tow bar and safety cables are removed.
- b. Disconnect your safety cables and wiring.
- c. Lift the release handles to unlock the arms. This will normally relieve tension on the Base Pin.
- d. Remove the Base Pins and store the **STERLING** on the motorhome by reversing the hook-up procedure.

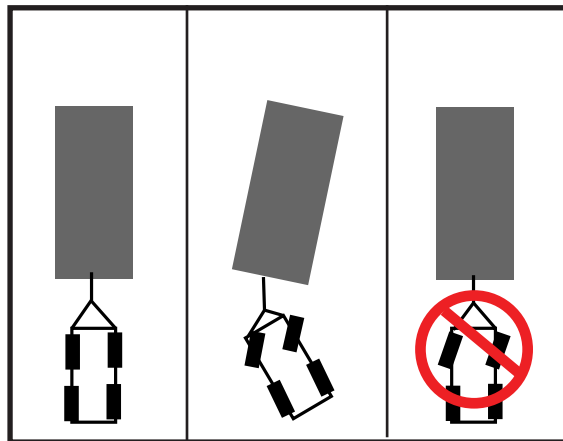

## IF YOU ARE EXPERIENCING ANY DIFFICULTY IN RELEASING THE LOCKING MECHANISM ON YOUR **STERLING**, TRY THE FOLLOWING:

Turn the steering wheel in the towed vehicle so the front tires are parallel to the motorhome as shown in Figure A and Figure B. Note that it is not necessary for the car to be parallel with the motorhome, **only the car's front tires**. This procedure should alleviate the tension on the locking mechanism allowing it to release more easily. If you are still having difficulty, then have someone get in the car (with the car running) and turn the steering wheel all the way left then right while you lift on the release handle. The locking mechanism should disengage.

**CAUTION:** Do not use any type of leverage tool to assist with lifting of the Sterling Release Handle. Doing so will damage the locking mechanism, and is not covered by warranty.

# WIRING INSTRUCTIONS

## Wiring the Plug.

1. Insert the end of the wiring cord through the safety channels. See illustration on page 12.
2. Wire the plug to match your vehicle or follow Figure A below. Apply silicone sealant to the wires where they attach to the plug. This will prevent moisture and corrosion and help assure a trouble free wiring system.

**Front of Plug on Cord**

Fig. A

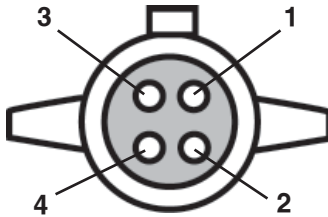

SOCKET PIN#	WIRE COLOR	MOTORHOME	CAR
2	WHITE	Ground	Ground
4	BLACK	Tail light	Tail light
1	YELLOW	Left turn / Stop	Left turn / Stop
3	RED	Right turn / Stop	Right turn / Stop

## Wiring the Sockets.

- Find a suitable location to install one of the electrical sockets on the front of the towed vehicle in reach of the existing 4-wire harness.
- Remove the screw on the back of the electrical socket. Push the inner connector out of the front. Now run the 4-wire through the back of the housing.

- Loosen all of the set screws on the side of the socket and connect the wires to the back of the socket as shown in the diagram below or wire the socket to match the existing wiring on the motorhome.

### ***Front of Socket on Towed Vehicle and Motorhome***

*Fig. B*

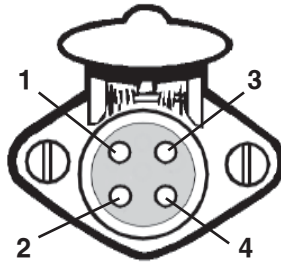

<b><i>SOCKET PIN#</i></b>	<b><i>WIRE COLOR</i></b>	<b><i>MOTORHOME</i></b>	<b><i>CAR</i></b>
2	WHITE	Ground	Ground
4	BROWN	Tail light	Tail light
1	YELLOW	Left turn / Stop	Left turn / Stop
3	GREEN	Right turn / Stop	Right turn / Stop

- Be sure to tighten all set screws and check each wire to see if it is secure. Use some clear silicone seal around each wire entry and set screw indentation. This will help to weather proof the socket and secure the set screws. Replace the protective boot.
- If your coach does not have the correct wiring socket already, you can replace it with the new socket for the 4 wire cord and connect the appropriate wires to the new socket according to the diagram.
- Now connect the 4-wire cord to the coach and towed vehicle. Test the lights for proper operation.

# SAFETY CABLES INSTRUCTIONS

**WARNING:** USE ONLY 6,000 LB. (or higher) RATED SAFETY CABLES

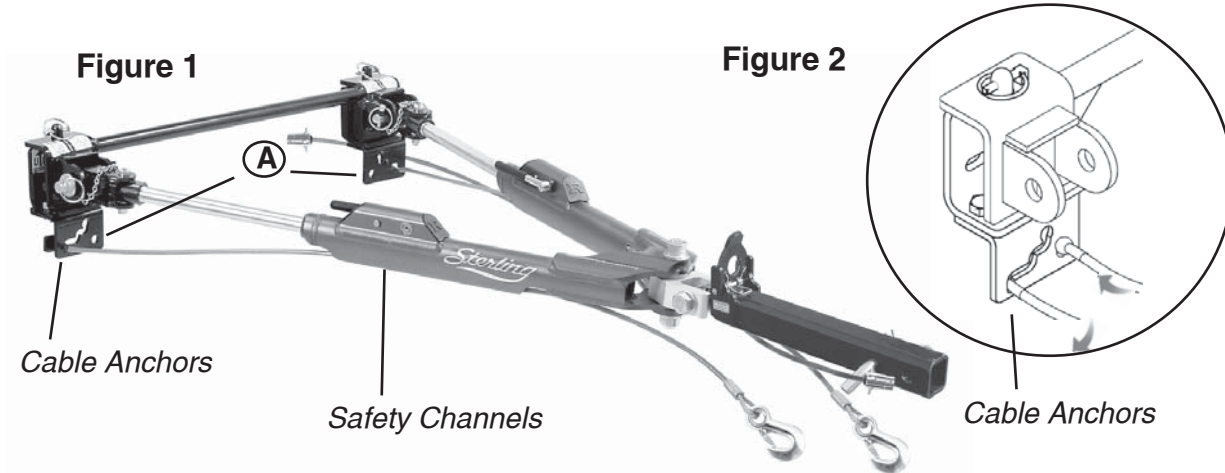

## ***Installation of Cables***

Route the safety cables through the safety channels by inserting the small end of the cable through the safety channel toward the towed car. Repeat for opposite side.

## ***Storing the Safety Cables and Wiring***

Double back the end of the safety cable through the channel to store. The wiring cable will fit inside the space created when the arms are folded together.

**Figure 3**

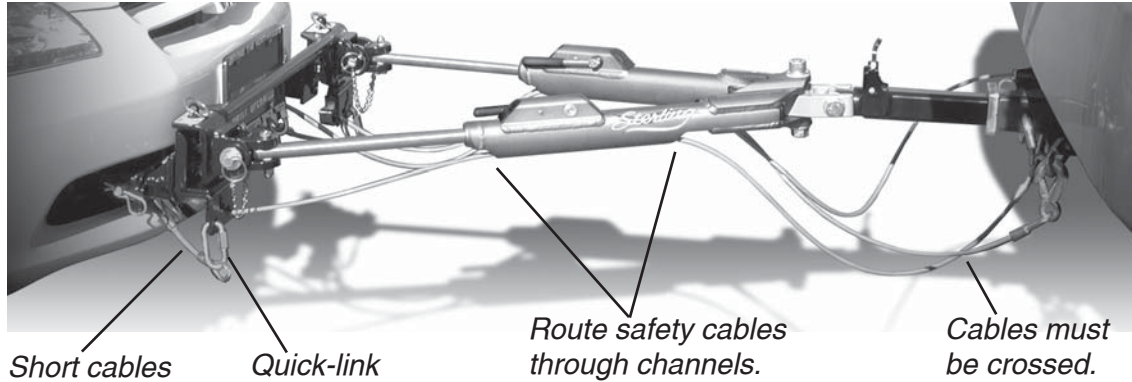

## ***How to Use Safety Cables***

- 1.** Connect the cables to the anchor bracket by inserting the cables through the anchor bracket and dragging down (Figure 2). If your baseplate has short cables on the car, attach them to holes "A" (Figure 1) with a Quick-link (not included).
- 2.** Always cross cables under the hitch as shown in Figure 3. In the event of hitch failure, the crossed cables may help support the tow bar preventing it from pole-vaulting the towed vehicle.

- 3.** Pull the safety cables so that all of the slack is at the motorhome.  
**IMPORTANT!: Cables too short: Make sure there is enough slack in the cables at the motorhome to allow for sharp turns.** If you have a hitch extension or other equipment that extends the distance between your towed car and motorhome the standard cables may be too short. Failure to use long enough cables will result in severe non-warranty damage to the towing system when turning sharp corners. If you require longer cables, contact Roadmaster, to custom make longer cables for your needs.

**IMPORTANT!: Cables too long:** On some hook-ups, the cables may be too long, and may allow the cables to hang too low. The cables will drag when traveling through dips and low spots resulting in non-warranty damage. If your cables are too long, you will need to wrap the excess cable around the bar to take up the slack. **REMEMBER TO LEAVE ENOUGH SLACK FOR TURNING SHARP CORNERS!**

- 4.** If you are connecting the Sterling to a ROADMASTER bracket that has removable arms, then you **MUST** use the short safety cables (that came with your brackets) to connect between the Cable Anchor and the portion of your mounting bracket that is permanently bolted to your towed car. This is required by law. You may lose your car if you do not properly use the safety short cables.
- 5.** Safety cables are rated at 6000 lbs. per pair. Your vehicle and all of its contents cannot exceed 6000 lbs.

**FAILURE TO FOLLOW THESE INSTRUCTIONS MAY RESULT IN  
PROPERTY DAMAGE, PERSONAL INJURY OR DEATH.**



## WARNING

- DO NOT TOW A VEHICLE USING TOW BAR, SAFETY CABLES, MOUNTING BRACKETS OR A HITCH RECEIVER RATED LESS THAN THE ACTUAL WEIGHT OF YOUR VEHICLE.
- SAFETY CABLES **MUST** CONNECT THE TOWING VEHICLE TO THE TOWED VEHICLE FRAME TO FRAME.
- **DO NOT TOW** YOUR VEHICLE UNTIL TOW BAR IS SECURE WITH ALL PINS AND/OR LOCKS. *Unless your tow bar is secured to both vehicles with all designated pins and/or padlocks, **YOU WILL LOSE YOUR TOWED VEHICLE.***
- **NEVER** HEAT, BEND OR WELD STERLING TOW BAR OR IT WILL WEAKEN METALS RESULTING IN NON-WARRANTY FAILURE.
- TOWED VEHICLE MUST HAVE EMERGENCY BRAKE SET & VEHICLE IN PARK WHEN HOOKING OR UN-HOOKING THE TOWED VEHICLE FROM MOTORHOME. FAILURE TO DO SO WILL CAUSE THE TOWED VEHICLE TO ROLL AWAY.
- USE CAUTION WHEN OPERATING THE TOW BAR TO BE SURE THAT YOUR HANDS, FINGERS OR ANY PART OF YOUR BODY DOES NOT GET CAUGHT BETWEEN ANY MOVING COMPONENTS. DOING SO CAN RESULT IN PINCHING, CRUSHING OR CUTTING CAUSING SEVERE PERSONAL INJURY.

FAILURE TO FOLLOW THESE INSTRUCTIONS MAY RESULT IN  
PROPERTY DAMAGE, PERSONAL INJURY OR DEATH.

**DO NOT TOW IF STERLING IS OVER 3 INCHES OUT OF LEVEL. See Caution on next page.**



Towing with an upward or downward slope of the tow bar puts undue strain on the tow bar and mounting brackets. **DO NOT TOW if the *STERLING* is over 3 inches out of level as shown.** To determine if your bar is at a safe angle:

- Connect motorhome and car on level ground.
- Measure from the ground to the center of the motorhome's receiver.
- Measure from the ground to the center of the base pin.
- Compare these two measurements. If they are more than 3" apart, you will need to use a Receiver Drop. This will increase or decrease the height of the motorhome's receiver. ROADMASTER manufactures several receiver drops in various heights to accommodate various out of level situations.

**FAILURE TO FOLLOW ANY ONE OF THESE WARNINGS MAY RESULT IN PROPERTY DAMAGE, PERSONAL INJURY OR DEATH**

## CAUTION!

If you use any kind of receiver extension, the tow bar **MUST** be no more than 3 inches out of level. **DO NOT TOW IF STERLING IS MORE THAN 3 INCHES OUT OF LEVEL while using receiver extension.** Extensions cause the towing system to swing much higher and lower when traveling in and out of dips. The enlarged arc of motion creates many problems:

- 1) Excessive strain on the tow bar, brackets and frame. Using extensions with an out of level tow bar can cause the towing system to fail and result in the loss of your towed vehicle.
- 2) Excessive suspension and tire wear on the towed vehicle.
- 3) Swaying and poor towing characteristics of the towed vehicle.

Towing more than 3 inches out of level while using extensions will void ROADMASTER's warranty.

**FAILURE TO FOLLOW THESE INSTRUCTIONS MAY RESULT IN  
PROPERTY DAMAGE, PERSONAL INJURY OR DEATH.**

## CARE & CLEANING

Your tow bar requires regular cleaning and lubricating to assure long term<sup>®</sup> trouble free operation. Use the following guidelines when maintaining your tow bar:

Always clean the bar before lubricating. Use Roadmaster's Voom! to clean the bar. It does an exceptional job of breaking down road film, dirt and grease. Spray a liberal amount on the tow bar, then operate the tow bar to work the cleaner into all of the moving parts. Spray cleaner into the lock housing access hole (directly under the lock mechanism) and activate the lock several times to work it in. Once you've cleaned the bar and wiped off the residue, extend the bar such that the cleaner can drain out of the arms. Wipe any remaining cleaner away before lubricating.

Now that you have a clean, dry tow bar. Spray a liberal amount of Silicone over the entire tow bar. Note: DO NOT SPRAY ANY SILICONE DIRECTLY INTO THE LOCK HOUSING OR THE LOCK HOUSING ACCESS HOLE! Silicone coats/covers in a thin layer. If you spray silicone inside the lock housing, it reduces the clearance for the locking mechanism preventing<sup>®</sup> proper operation.

Proper cleaning<sup>®</sup> and lubrication of the tow bar will prevent corrosion on your tow bar and provide smooth operation.

®

®

**TIP:** Keeping the Base Pins clean and lubricated will help ease the disconnect process. Use Silicone over the entire surface of the tow bar to help preserve the finish.

# PARTS AND COMPONENTS

357000-00 Quick-Disconnect Linch Pin

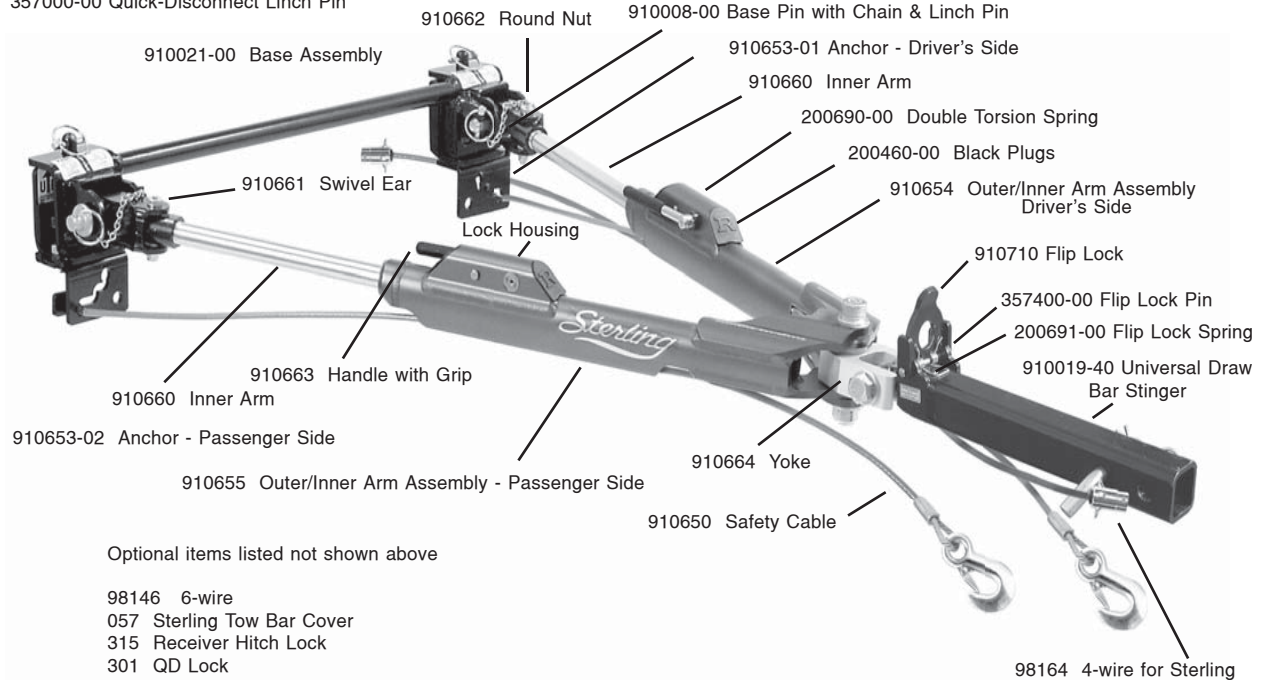

Optional items listed not shown above

- 98146 6-wire
- 057 Sterling Tow Bar Cover
- 315 Receiver Hitch Lock
- 301 QD Lock
- 302 2-pack QD Locks
- 305 Coupler Lock
- 304 2-pack QD Locks plus Receiver Hitch Lock

# ***ROADMASTER LIMITED WARRANTY***

**ROADMASTER**, Inc. warrants to the original retail purchaser-consumer of this product that such product when used for its normal intended purposes is free of defects in workmanship and materials. This warranty, together with any and all warranties implied by law, shall be limited to a duration of one (1) year from the date of purchase by the original retail purchaser-consumer and is not transferable.

This warranty only covers failures due to defects in materials or workmanship which occur during normal and proper use and does not cover damage which occurs in shipment, backing up with "towed" vehicle attached or failures which are caused by products not supplied by **ROADMASTER**, Inc or failures which result from normal wear, misuse, abuse, neglect, mishandling, misapplication, faulty installation, setup adjustments, improper maintenance, alteration, maladjustment, modification, commercial use or service of the product by anyone other than **ROADMASTER**, Inc. Furthermore, this warranty does not apply to any product or material or part which has been installed, maintained or used contrary to the operating, maintenance or installation instructions and shall not apply to any parts or materials used in the installation that were not supplied with the product in the original carton or to any damage which said parts or materials may cause.

THIS WARRANTY DOES NOT COVER, AND IS INTENDED TO EXCLUDE, ANY LIABILITY ON THE PART OF **ROADMASTER**, Inc, WHETHER UNDER THIS WARRANTY OR UNDER ANY WARRANTY IMPLIED BY LAW, FOR ANY INCIDENTAL OR CONSEQUENTIAL DAMAGES. SOME STATES DO NOT ALLOW THE EXCLUSION OR LIMITATION OF INCIDENTAL OR CONSEQUENTIAL DAMAGES, SO THE ABOVE LIMITATION OR EXCLUSION MAY NOT APPLY TO YOU.

# ROADMASTER LIMITED WARRANTY CONT.

## *RESPONSIBILITY OF ROADMASTER, INC.*

With proof of date of purchase by the consumer, **ROADMASTER**'s responsibility under this warranty shall be limited to the repair or replacement (at its option) of any product or part which is actually defective at no charge to the consumer except for shipping and/or mailing charges. In no event shall **ROADMASTER**'s liability under any claim or theory exceed the purchase price of the equipment in respect of which damages are claimed. No agent, representative, dealer or employee has the authority to alter or increase the obligations or limitations of this warranty. All specifications are subject to change without notice.

## *RESPONSIBILITY OF THE PURCHASER*

In order to qualify for this warranty, the purchaser must completely fill out and, within thirty (30) days of purchase, send to **ROADMASTER**, Inc. the attached warranty registration card. The purchaser must contact **ROADMASTER**, Inc. prior to returning any product so that **ROADMASTER** may determine the nature and extent of the claim and to obtain a return authorization number. Returned products must include the return authorization number and a copy of the sales slip as proof of purchase. The date of purchase must coincide with the original warranty registration card on file. If return of the product is required, it must be shipped prepaid via UPS to **ROADMASTER**'s address.

# **ROADMASTER, INC.**

*Towing and Suspension Solutions*

6110 NE 127th Ave. Vancouver, WA 98682 1-800-669-9690 [www.roadmasterinc.com](http://www.roadmasterinc.com)