



Time Tested • Time Proven

855392-00 03-15

Hitch Receiver Extension

part number 071-1075

Installation instructions and user's guide

All specifications are subject to change without notice.

ROADMASTER, Inc. 6110 NE 127th Ave. Vancouver, WA 98682 800-669-9690 Fax: 360-735-9300 www.roadmasterinc.com

Installation instructions

1. Slide the end of the extension into the hitch receiver, align the holes and secure the extension to the receiver with the threaded bolt and clip (Figure 1).

To prevent hitch rattle, tighten the bolt until it is snug.

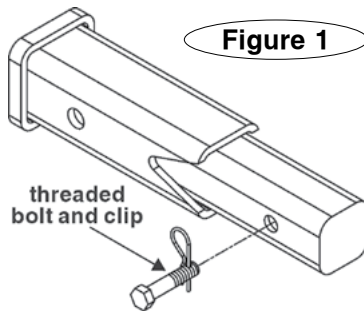

Figure 1

! WARNING

Always use the clip to secure the extension. The bolt may work loose without the clip, which will cause the extension to separate.

Failure to follow these instructions may result in property damage, personal injury or even death.

2. Insert the draw bar into the other end of the extension; secure with a hitch pin and clip or follow the manufacturer's instructions.

NOTE: to prevent theft or accidental release, ROADMASTER recommends substituting a receiver hitch lock (part number 315) for the hitch pin and clip.

! WARNING

Do not use more than one hitch receiver extension at any given time, for any application.

The extensions are not designed to be linked together. Multiple extensions may cause the towing system to fail.

tem to fail.

Significant property damage, personal injury or even death can result if multiple extensions are used.

3. If towing a vehicle or trailer, make certain there is enough slack in the safety cables (or chains) to allow for sharp turns.

If the safety cables (or chains) are too short, you must either: 1) add extensions; or 2) purchase longer safety cables (or chains).

! WARNING

Hitch extensions will extend the distance the safety cables (or chains) must reach. If the safety cables are too short, severe non-warranty damage will occur to the towing system.

Damage to both vehicles may also occur.

! WARNING

Do not use the hitch receiver extension if it drags going over dips, railroad tracks or other uneven road surfaces. The steel will be severely weakened by the force of the impact, which may cause the shank (Figure 2) to bend or break.

Inspect the bottom of the extension after each trip thereafter to make certain that it has not come into contact with the road.

Failure to follow these instructions may cause property damage, personal injury or even death.

continued on next page

IMPORTANT NOTICE!

Safety definitions

These instructions contain information that is very important to know and understand. This information is provided for safety and to prevent equipment problems. To help recognize this information, observe the following symbols:

! WARNING

WARNING indicates a potentially hazardous situation which, if not avoided, could result in property damage, serious personal injury or even death.

NOTE

Refers to important information and is placed in italic type. It is recommended that you take special notice of these items.

Towing and tongue weight capacities

The maximum towing capacity of the 071-1075 hitch receiver extension is 10,000 pounds; the maximum tongue weight is 400 pounds.

“Maximum towing capacity” is the **maximum** allowable weight of the fully loaded vehicle, including its contents.

“Maximum tongue weight” is the **maximum** allowable vertical load applied to the extension (including the weight of any accessory attached to the extension).

! WARNING

Do not exceed the maximum towing capacity or the maximum tongue weight, or the hitch receiver extension will fail, which may cause the towed vehicle to separate from the towing vehicle.

Property damage, personal injury or even death can result.

continued from preceding page

 **WARNING**

Do not drill a second hole in the shank of the hitch receiver extension.

Drilling a second hole will weaken the steel and may cause failure. Refer to Figure 2.

Failure to follow these instructions may cause property damage, personal injury or even death.

 **WARNING**

Receiver extensions cause the towing system to swing much higher and lower than towing systems without extensions. This enlarged arc of motion can create excessive strain on the towing system, resulting in failure.

For these reasons, do not tow if the trailer or tow bar is more than three inches out of level.

