

# TOWMASTER 2

by Roadmaster

1,700 kilogram capacity A-frame  
part number 5052-EUJ

*Entire contents of manual must be read by owner*

*manufactured by*



**Time Tested • Time Proven**

ROADMASTER, Inc. • 6110 NE 127th Ave. • Vancouver, WA 98682

800-669-9690 • Fax 360-735-9300 • roadmasterinc.com

© 2017-2020 ROADMASTER, Inc. All rights reserved. 855827-01 06.19

# Welcome to the ROADMASTER family!

---

This manual has been prepared to acquaint you with the installation, operation, care and maintenance of your A-frame, and to provide you with important safety information.

Read your owner's manual cover to cover. Understand how to install and operate your A-frame, and carefully follow the instructions and safety precautions.

We thank you for your patronage and greatly appreciate your discerning taste.

## Contents

Safe towing practices .....	1
Connecting and disconnecting	
Connecting the A-frame .....	2-3
Disconnecting the A-frame .....	4
Care and cleaning .....	4
Coupler information .....	5
Parts .....	6

## Save this manual

Save this manual for future reference. It contains important sections relative to safety, use, maintenance and other information. Therefore, make sure this manual is always with you when you're towing.

You may download or print a copy of the most current manual at [www.roadmasterinc.com](http://www.roadmasterinc.com) (under 'Support').

## Your A-frame serial number...

...is located on the exterior of one of the A-frame arms.

Write down the serial number in the space below and retain for future reference.

Serial number: \_\_\_\_\_

All illustrations and specifications contained herein are based on the latest information available at the time of publication. ROADMASTER, Inc. reserves the right to make changes, at any time, without notice, in material, specifications and models, or to discontinue models.

## WARNING

**Read all instructions before installing the A-frame, or before towing a vehicle. Failure to understand how to properly install or operate the A-frame could result in property damage, personal injury or even death.**



# Safe towing practices

To ensure your safety and that of your passengers, as well as the safety of others on the road, follow these safe towing practices at all times.

## CAUTION

**Do not reverse the towing vehicle with the towed vehicle attached.**

**Backing up with the towed vehicle attached may cause the towed vehicle to “jackknife,” which could cause non-warranty damage to the A-frame.**

- **Be sure the vehicle can be towed** before taking it on the road. Failure to properly equip the vehicle will cause severe damage to the transmission or the transaxle, unless the vehicle’s manufacturer has approved the vehicle for flat towing. If this is the case, check the vehicle’s owner’s manual for the proper procedure(s) to prepare the vehicle for towing.

- **The A-frame must be approximately level with the ball hook on the motorhome** – no more than four inches above or below level.

Towing with the A-frame at a severe upward or downward slope may force the coupler off the ball hook on sharp inclines or declines.

- **The steering wheel must be unlocked and free to turn when towing.** Failure to do so can cause severe tire and equipment damage.

- The TowMaster A-frame is rated at a maximum of 1,700 kilograms carrying capacity; therefore **the weight of the towed vehicle and all its contents cannot exceed 1,700 kilograms.**

- **The A-frame must be properly secured with pins before towing.** Unless the A-frame is secured to both vehicles with all appropriate pins, the towed vehicle will detach.

- **Inspect the system before towing** – if any component is damaged, replace it before towing. Also, check the coupler ball clamp and ball socket (Figure 1) for fractures or cracks in the steel.

- **This A-frame is designed for use on paved roads only.** ROADMASTER does

not recommend off-road towing, nor does ROADMASTER warrant the A-frame for off-road use.

- **Never tow a vehicle with one of a comparable weight.** The towed vehicle’s weight should never exceed 40 percent of the towing vehicle’s weight.

Towing a vehicle with one of similar weight will cause the towed vehicle to override the towing vehicle, resulting in “jackknifing.” Serious damage to both vehicles, as well as the towing system, could result.

- **Always stand to one side and as close to the motorhome as possible when releasing the A-frame locking**

**mechanisms.** Never stand between the A-frame arms, or put any part of your body between the A-frame arms, when releasing the A-frame – the towed vehicle may lurch forward when the locking mechanisms are released.

- **Check the motorhome turning radius.** Some motorhome chassis have such a tight turning radius that the motorhome can hit the towed vehicle. Before getting on the road with your towed vehicle, you should test your turning radius in an empty parking lot.

- **Keep the A-frame clean and well-lubricated.** As is the case with most precision equipment, frequent cleaning and care results in better performance and longevity.

Refer to the section titled “Care and cleaning” for further information.

## ⚠ WARNING

**Failure to follow these instructions may cause property damage, personal injury or even death.**

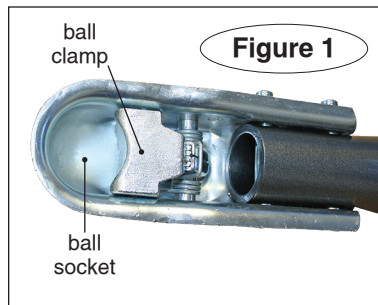



# Connecting the A-frame

## Center and adjust the A-frame

*Note: it is only necessary to center and adjust the A-frame once for any particular vehicle.*

1. Insert both of the cam arms (Figure 2) through the holes in the towed vehicle's fascia and into the holes in the bumper core.

Then push each cam arm into the bumper core and rotate it 90 degrees, so that the arm is locked into the bumper core (Figure 2). Test by pulling each cam arm to make certain that it is locked and cannot pull out.

## WARNING

**Both cam arms must be locked before towing. If they are not, the tow bar will disengage, causing the loss of the towed vehicle. Property damage, personal injury or even death will result.**

The cam arms will now be oriented so that the holes at the end are parallel with the ground (Figure 2).

2. Loosen the two bolts near the yoke (Figure 3) so that the outer arm can rotate.

3. Holding both of the A-frame arms together, attach either arm to its corresponding cam arm with the included pin (Figure 3).

4. Extend the other A-frame arm across the towed vehicle and attach it to the other cam arm.

5. Pull the coupler (and the two A-frame arms with it) away from the towed vehicle, as far as they will go. The coupler must be approximately centered between the cam arms on the bumper core.

Both locking mechanisms (the 'Freedom Latches,' Figure 3) will engage.

6. Using a torque wrench, tighten the two bolts at the yoke (Figure 3) to 71 ft./lbs. (96 N-M).

7. The A-frame is now centered and adjusted to your towed vehicle.

If you wish to tow a different vehicle with the A-frame, untighten the two yoke bolts and repeat the steps above.

To connect the A-frame for towing, follow the steps below.

## Connecting the A-frame for towing

1. Drive the towed vehicle within three to four feet of the motorhome.

Put the vehicle in gear (park), set the emergency brake and chock one of the wheels.

2. Connect both A-frame arms to the cam arms with the included pins (Figure 4).

The pins must be locked. The rings are spring-loaded – they must be snapped over the pin, with the pin touching the ring, in order to keep the tow bar secure (Figure 5). If a pin does not touch the ring, rotate the pin around the ring.

## WARNING

**Towing vibrations will force the pins out unless they are properly locked in place. Refer to Figure 5. Failure**

*continued on next page*

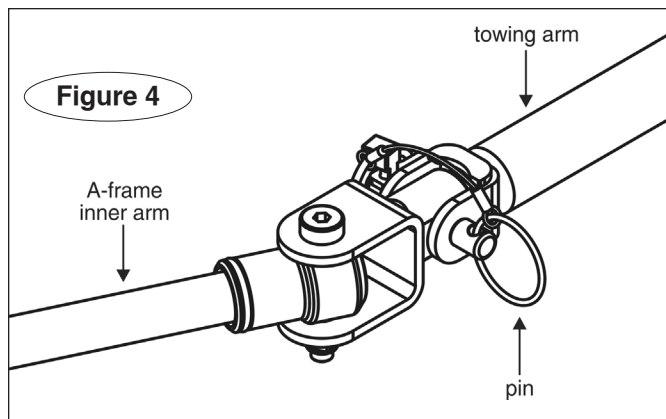
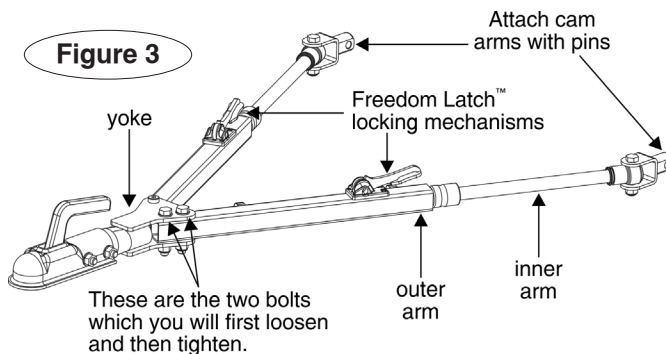
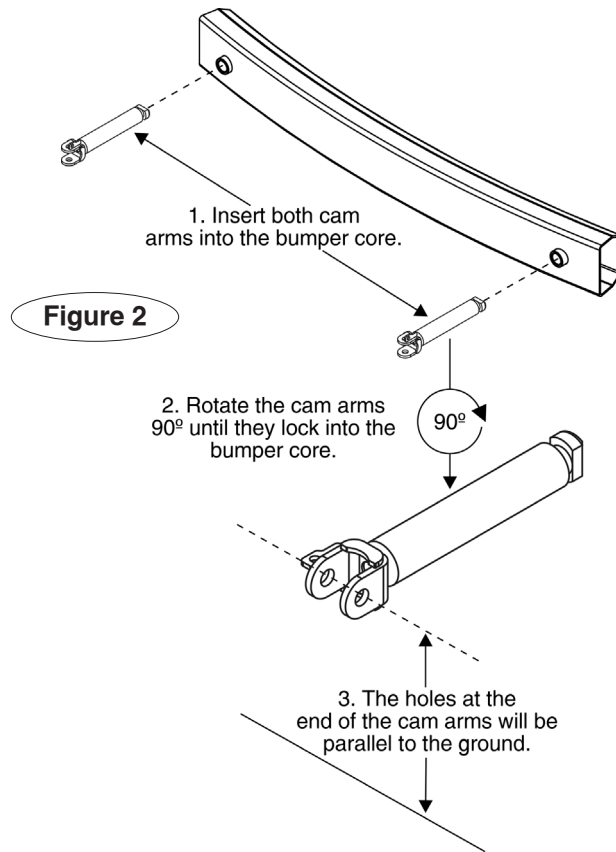

## Connecting the A-frame

*continued from preceding page*

**to properly attach and lock all pins will result in the loss of the towed vehicle, which may cause property damage, personal injury or even death.**

3. Lift the coupler up and move it forward or backward, as needed, to maneuver it over the ball hook.

If one of the A-frame arms does not slide forward or backward, lift the handle of the locking mechanism on that tow bar arm to unlock it.

4. Press and hold the coupler locking trigger (Figure 6) and lift the handle (Figure 6) up.

Lower the coupler over the ball hook so that it completely covers it; release the handle.

5. Be certain the coupler is properly locked onto the ball hook – the handle must be completely lowered, as shown in Figure 6, with the coupler completely covering the ball hook, for the coupler to be locked onto the ball hook.

### **WARNING**

**If the coupler is not properly locked onto the ball hook, as described above, it will release during towing. The A-frame will separate from the motorhome, which may cause property damage, personal injury or even death.**

6. Plug in the lighting power cord according to the supplier's instructions and verify that all lighting systems are functioning. Use the two spring clips along the inside of one of the tow bar arms to secure the power cord.

Before towing the vehicle, make certain that the steering is unlocked, the transmission is in the proper setting, and the emergency brake is released. Remove the wheel chock.

Check the owner's manual for the proper towing procedures or requirement(s) for the vehicle to be towed.

### **WARNING**

**Do not tow the vehicle until the A-frame is properly attached with all pins, or the vehicle will detach, which may cause property damage, personal injury or even death.**

When you drive away, steer briefly to the left and then to the right, to extend, self-center and lock the A-frame.

Always stop at this time. Check the A-frame to ensure that both arms are locked, before assuming highway speed. Additionally, check the other components of your towing system, to ensure that they are fully engaged.

### **WARNING**

**Both A-frame arms must be locked before towing. If they are not, the momentum of the towed vehicle will apply excessive force to the A-frame arms and other components of the towing system, which may cause the towing system to fail, resulting in property damage, personal injury or even death.**

### **WARNING**

**Do not tow a vehicle with a ball hook or any supple-**

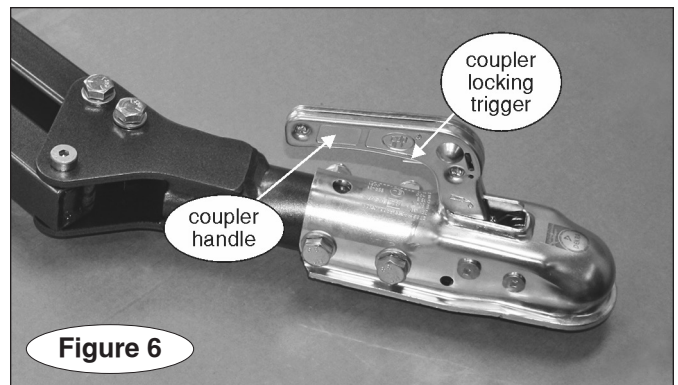
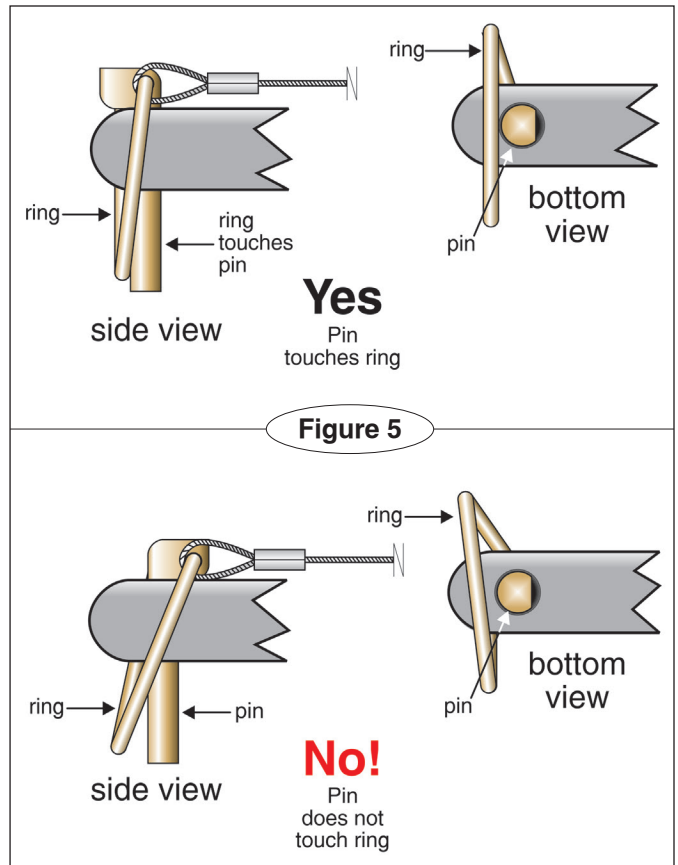

**mentary equipment rated less than the actual weight of the towed vehicle and all its contents.**

**If any supplementary towing equipment is not rated at the weight of the towed vehicle and all its contents it may fail during towing, causing property damage, personal injury or even death.**

## Disconnecting the A-frame

1. Disconnecting the A-frame is essentially the reverse of connecting it.

Before you begin, always try to park on level ground, with the towed vehicle in line with the motorhome. This will eliminate most of the tension between the two vehicles, allowing for an easier disconnect.

2. Chock one of the wheels, to prevent a runaway vehicle.
3. Lift the release handles (the Freedom Latches, Figure 3) on each tow bar arm to release the locking mechanisms.

### **WARNING**

**When the locking mechanisms are released, the towed vehicle may surge forward. For this reason, always stand to one side when disconnecting the A-frame. Never stand between the A-frame arms, or put any part of your body between the A-frame arms.**

4. Pull back on the coupler locking trigger and lift the handle (Figure 6) to release the coupler. Lift the coupler off the ball hook.

*Note: if you must park on an uphill incline, you may find that you cannot release the coupler even with the tow bar arms released. The weight of the towed vehicle trying to roll back (Figure 7) is binding the pins (Figure 4) in place.*

*Allow the towed vehicle to idle forward just enough to take the tension of this weight off the pins. Then hold the vehicle in position by first applying the emergency brake, then shifting into park.*

*Once the tension is off, pull back on the coupler locking*

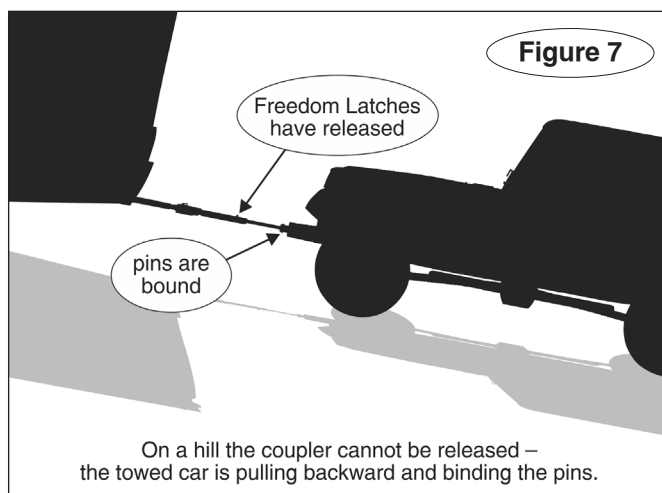

*lever to release the coupler.*

5. Pull the pins from both of the A-frame arms to disconnect them; collapse the arms.
6. Store the A-frame in any covered location that will protect it from the elements, or in its optional carry bag, part number 5052-BAG.
7. Remove both cam arms (Figure 2).

### **WARNING**

**Both cam arms must be removed when driving the towed vehicle. Otherwise, road vibrations will cause them to detach, which may present a hazard to other motorists. Property damage, personal injury or even death may result.**

## Care and cleaning

As is the case with most precision equipment, frequent cleaning and care results in better performance and longevity. Use the following guidelines to keep your A-frame clean and well-lubricated.

Always clean the A-frame before lubricating. Use an all-purpose, water-soluble cleaner to break down road film, dirt and grease.

### **CAUTION**

**Do not use petroleum-based products to clean or lubricate the A-frame. Petroleum will attract dirt and dust, which will make the arms difficult to slide.**

Clean all moving components, paying special attention to the inner arms and the locking mechanisms (the Freedom Latches). No matter what part is being cleaned, the method is the same – 1) spray a liberal amount of cleaner over it; 2) move the component back and forth to work out any accumulated dirt; 3) wipe it down; and 4) repeat until clean.

Spray cleaner at the intersection of the inner/outer arm assembly. Move the inner arm in and out to flush out dirt. Wipe the dirt off and repeat until the arm is clean; repeat for the other arm.

To clean one of the locking mechanisms, first spray cleaner into the mechanism, then move the release handle up and down to flush out dirt from the bottom of the assembly.

Now that you have a clean, dry A-frame, use a dry silicone spray to lubricate the A-frame – spray a liberal amount of silicone into all moving components, including the Freedom Latch locking mechanisms.

Flex the A-frame components, and push and release the locking mechanisms, to work the lubricant in.

### **CAUTION**

**Always clean the locking mechanisms before lubricating them. Silicone coats and covers in a thin layer. If it is not removed, it will reduce the clearance for the locking mechanisms, preventing proper operation.**

Lubricate the coupler ball socket and ball clamp. The manufacturer's instructions are on the next page

# Coupler information

Following are the coupler manufacturer's operation, latching and maintenance instructions, for your reference.

## Assembling, operating and maintenance instruction of coupling heads ZSK and BC type

### 1. Introduction

Coupling heads are made in accordance with the Directive 94/20/EWG and the Regulations ECE-R55. Coupling heads are of great importance for road safety, therefore numerous tests have been carried out to confirm their reliability. Nevertheless, to ensure their reliability it is essential that coupling heads are properly assembled, operated and maintained. Therefore, please read this instruction very carefully and follow all the directions.

### 2. Range of application

Coupling heads can be used only with those trailers where the required parameters marked on the trailer casing have not been exceeded. All coupling heads are to be coupled with A class tow-hook balls (50 mm in diameter) that are made in accordance with the Directive 94/20/EWG and the Regulations ECE-R55.

Ranges of rotation – see Figure A

### 3. Assembling instruction

A coupling head should be fastened so that the coupling point of the trailer (with horizontal positioning of the bodywork, the maximum permissible "Pmax" axle load and properly placed load) does not exceed the permissible S value (vertical thrust) engraved on the body of the coupling head, and is 430 ±35 mm above the surface of the tyre adhesion to the ground – see Figure B. All deviations must be taken into consideration when approving the trailer construction. Coupling heads (depending on a design) may be fastened onto pipe shafts (round or square), V-shaped shafts and inertia brake couplings.

#### 3.1. Assembling to a pipe shaft (round or square)

The casing of the coupling head should be placed on the shaft, properly positioned to the holes and screwed down with 2 bolts, 2 self-retaining nuts, 4 washers and 2 distancing jointing sleeves – see Figure C. When there are three vertical fastening holes, only two are to be used i.e. the front fastening hole and one of the rear ones.

#### 3.2. Assembling to a V-shaped shaft

The recommended way of fastening the coupling heads of ZSK-750K and BC-800L type to a V-shaped shaft with steel sections that are up to 24 mm wide and up to 60 mm high with the use of a connector, horizontally placed 4 fastening screws M12x35 (ISO 4017), 4 self-retaining nuts, M12 (ISO 7040), and 8 washers 12.5 mm inside diameter (ISO 7090), is shown in detail in – see Figure D.

The other method of fastening the coupling heads of ZSK-750K and BC-800L type to a V-shaped shaft with steel sections that are up to 30 mm wide and over 60 mm high with the use of a connector, 2 vertically placed fastening screws M12 x 35 (ISO 4017), 2 self-retaining nuts M12 (ISO 7040) and 4 washers 12.5 mm inside diameter (ISO 7090) – see Figure E.



It is obligatory to check if all the bolts are screwed down properly after 1,000 kilometers.

### 4. User's manual

In order to couple and uncouple the trailer safely one should

- Make sure that there is a vacant space round the ball of the hook to exclude possible collisions with the spare wheel, frame and other bodywork elements.
- The trailer should be loaded properly, without exceeding the permissible total weight "Pmax," so that the thrust on the coupling ball does not exceed the "S" value (marked on the body of the coupling head) – see Figure B.
- To make sure that the coupling head is properly fixed it is important to check the position of the indicator and the clearance between the coupling head and the ball of the hook – see Figure F.
- If the coupling between the ball and the coupling head slackens e.g. clatters start occurring during driving, it means that either the ball or the coupling head is used up and should be replaced at once. The diameter of the ball should be at least 49.13 mm. If the value is smaller it indicates that the coupling ball is used up.
- If a coupling head should get damaged or deformed in an accident or because of overload, it should instantly be replaced.
- Being of great importance for road safety, coupling heads should not be altered in any way.

### 5. Operating instructions of BC and ZSK type coupling heads

- In order to open the coupling head, push the safety bolt 'R' with the index finger upward and turn the coupling handle 'D' forward – see Figure G.
- The coupling head is opened when the indicator is in the OPEN position – see Figure F.
- In order to couple a coupling head, place the opened coupling head on the ball and push the coupling handle 'D' downward – see Figure H, until the bolt 'R' clicks outside.
- The coupling head is coupled properly if the safety bolt 'R' clicks outside and the indicator is in position  – see Figure F.
- If the indicator is in position  – see Figure F, it means that either the coupling head is fixed incorrectly or that the parts of the coupling head or the ball are worn and should be replaced immediately.

### 6. Maintenance

Proper maintenance will provide easy exploitation and proper functioning of a coupling head. To ensure that all joints and bearings should be lubricated – see Figure G, and the holding clamp should be cleaned and lubricated regularly.

Table of tightening moments for screws

Screw Size	Resistance Class	Tightening Moments
M10	8.8	46 Nm
M12	8.8 / 10.9* / 12.9**	79 Nm / 115 Nm / 137 Nm
M14	10.9*	180 Nm

\* Use for fitting the ball couplings of permissible maximum mass of a trailer above 1500kg to 2999kg.  
 \*\* Use for fitting the ball couplings of permissible maximum mass of a trailer above 3000kg.

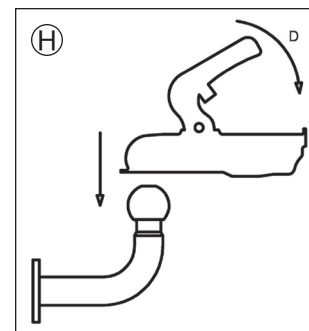
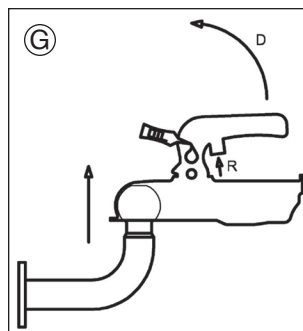
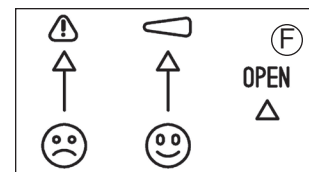
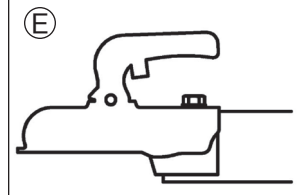
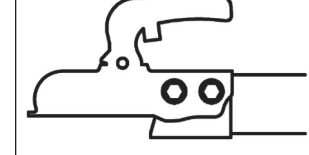
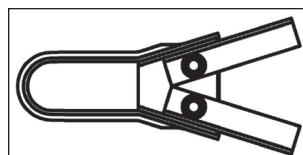
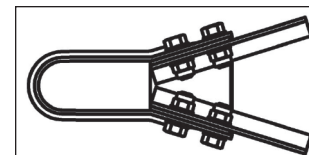
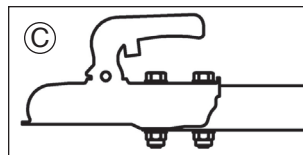
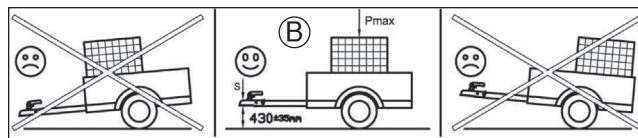
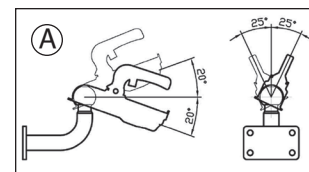



# TowMaster II parts

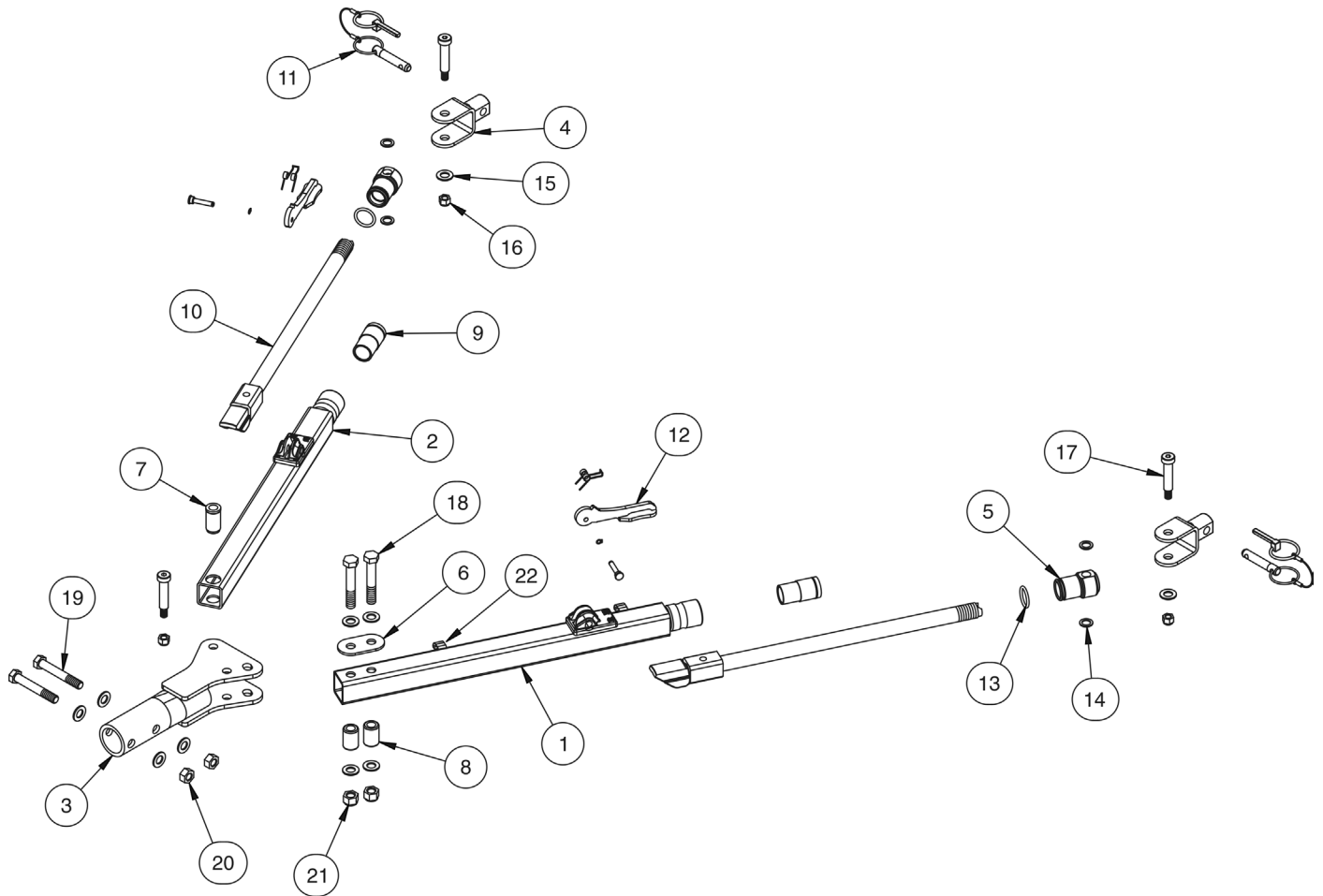

Item Number	Quantity	Part Number	Description
1	1	C-003232	Outer arm side one
2	1	C-003233	Outer arm side two
3	1	C-002851	Yoke
4	2	C-003234	Swivel collar
5	2	A-005504	Round nut
6	1	A-004976	Shim plate
7	1	A-001418	Step bushing
8	2	A-001413	Insert spacer
9	2	200029-70	Nose cone bushing
10	2	910552	Inner arm assembly
11	2	910047	Draw pin assembly
12	1	910003-45	Freedom latch assembly
13	2	200382-00	O-ring
14	4	350356-00	1/2" nylon washer

Item Number	Quantity	Part Number	Description
15	10	355720-00	M12 flat washer
16	3	350255-00	3/8-16 nyloc nut
17	3	350376-00	1/2" x 2" socket head shoulder bolt
18	2	350101-00	1/2-13 x 3" grade 5 hex bolt
19	2	357211-80	M12 x 1.75 x 80mm class 8.8 hex bolt
20	2	357212-50	M12 x 1.75 nyloc nut
21	2	350259-00	1/2-13 nyloc nut
22	2	357042-00	spring clip