

Slipper Spring Kit (part number 2580)

Item	Qty	Description	Part
1	8	3/8-16 x 1" GRADE 8 SELF TAPPING SCREW	350054-50
2	4	7/16-14 x 3-3/4" GRADE 5 BOLT	357044-00
3	6	9/16-12 x 4" GRADE 8 BOLT	350531-00
4	4	7/16-14 GRADE 5 NYLON INSERT LOCKNUT	350257-00
5	6	9/16-12 GRADE 8 NYLON INSERT LOCKNUT	350261-25
6	8	WEDGE WASHER	350308-50
7	4	9/16" GRADE 8 FLAT WASHER	350347-20
8	2	1" O.D. x 0.640" I.D. x 2" SPACER	A005848
9	4	WEAR PAD	C003558
10	4	3/4" O.D. x 0.500" ID. x 2 1/2" SPACER	A006291
11	2	SLIPPER SPRING BOX	B004008
12	4	8K LEAF SPRING-2580	D000110



Comfort Ride 2580

Slipper spring system
and shock absorber system (sold separately)
(part numbers 2450, 2460 and 2470)

Installation Instructions

All specifications are subject to change without notice.

Shock System Kit (part numbers 2450, 2460 and 2470)

Item	Qty	Description	Part
13	4	SHOCK ABSORBER	204000-00
14	8	1/2-13 x 1 1/2" GRADE 5 BOLT	350095-00
15	8	1/2-13 GRADE 5 NYLON INSERT LOCK NUT	350259-00
16	24	M12 FLAT WASHER	355720-10
17	8	M12 x 1.75 x 100mm BOLT - CLASS 8.8	357211-100
18	8	M12 x 1.75 NYLON INSERT LOCK NUT	357212-50
19	4	EXTENSION PLATE	A005494
20	8	1/2" SPACER	A005764
21	2	TIE PLATE FOR 2 3/8" AXLE-2450	C003264
	2	TIE PLATE FOR 3" AXLE-2460	C003169
	2	TIE PLATE FOR 3 1/2" AXLE-2470	C003294
22	2	TIE PLATE FOR 2 3/8" AXLE-2450	C003265
	2	TIE PLATE FOR 3" AXLE-2460	C003170
	2	TIE PLATE FOR 3 1/2" AXLE-2470	C003295

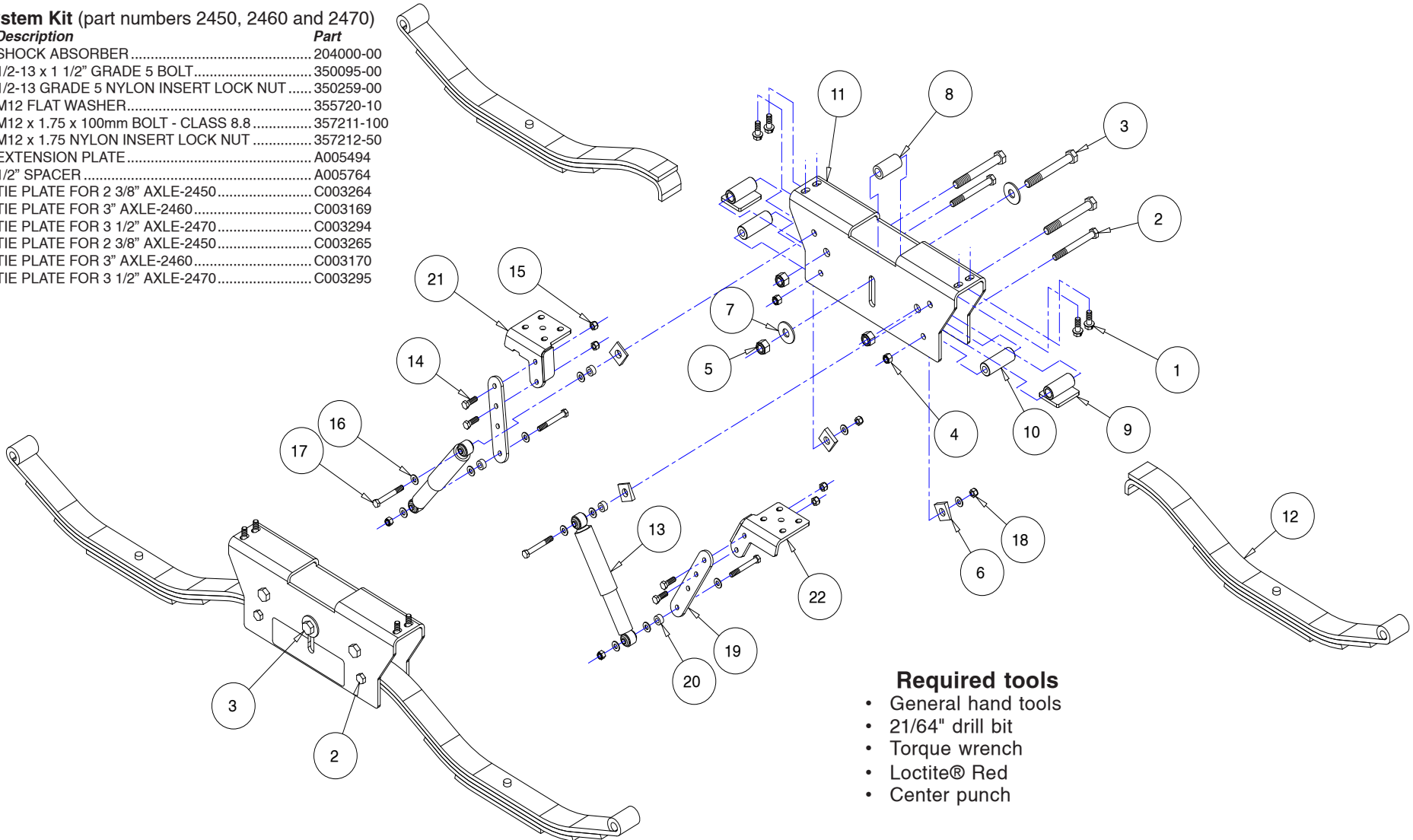

Required tools

- General hand tools
- 21/64" drill bit
- Torque wrench
- Loctite® Red
- Center punch

Before you begin the installation...

WARNING



Read all instructions before you install this product. Failure to understand how to install this product could result in property damage, personal injury or even death.

Note: If you're a professional installer, please give these instructions to the customer once the kit is installed.

Note: For ease of installation, the shock absorbers (sold separately) are shipped with restraining bands to hold them at a specific length. Don't remove the restraining bands until instructed to do so.



ROADMASTER, Inc. • 6110 N.E. 127th Ave.
Vancouver, WA 98682 • 800-669-9690
Fax 360-735-9300 • roadmasterinc.com
856166-14 06.23

CAUTION

If you are installing this kit on a triple axle trailer, refer to the instructions that came with that kit before proceeding with this installation.

Please also note that the leaf springs are to be used only in conjunction with a Comfort Ride shock absorber system. Don't install the leaf springs by themselves.

- Check that you have the correct kit. Kit number 2560 is for axles up to 5,000-pound capacity; kit number 2570 is for up to 7,000-pound capacity axles; and kit number 2580 is for up to 8,000-pound capacity axles.
- Ensure that the U-bolts attaching the trailer's leaf springs to the axles have at least $\frac{3}{4}$ " of thread showing beyond the nut. **Note:** If you need longer U-bolts, order **part 2630** for the 3" axles or **part 2635** for 3 $\frac{1}{2}$ " axles. You will need one pair per axle.
- Check for under-vehicle obstructions near the trailer's suspension (such as plumbing, wiring or other trailer components) that may prevent the installation of the product. It may be necessary to modify or relocate components in order to install this product.



Installation

1. Lift the trailer by the frame so that the suspension hangs. Ensure the trailer is level at all four corners.

CAUTION

Don't lift the trailer by the axles. Doing so could adversely affect the alignment of the axles or result in a bent or otherwise damaged axle.

2. Remove the wheels and tires.
3. Support all axles at both ends with stands. Position the stands at the ends of each axle, not in the middle.

4. Detaching the axles from the springs:
 - a. Test to see if the axle U-bolts can be removed. If they cannot, soak them in a quality penetrating oil.
 - b. Ensure that the trailer brake wiring will not be damaged when the axles are detached from the springs.
 - c. Detach the axles from the springs by removing the axle U-bolts and tie plates (Figure 2). Keep the tie plates and hardware for reinstallation.
5. How to remove the spring hanger bolts (Figure 3):

CAUTION

Do not attempt to turn the spring hanger bolt heads. On many trailers, these are splined bolts. If you turn the bolt head, the bolt may break and/or the spring hanger flanges may be damaged.

Follow the instructions below to remove them.

- a. Remove the spring hanger nuts from the bolts.
- b. Use a C-clamp or similar device to secure the spring hanger flanges to each other so they don't bend when the bolt is driven out.

continued on next page

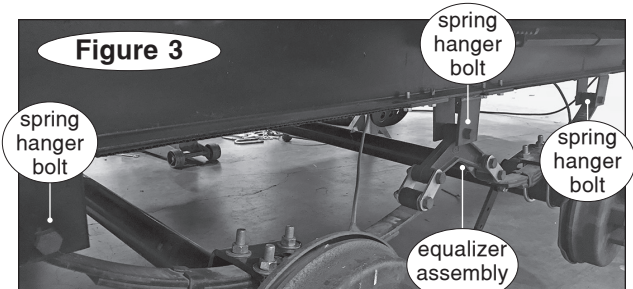
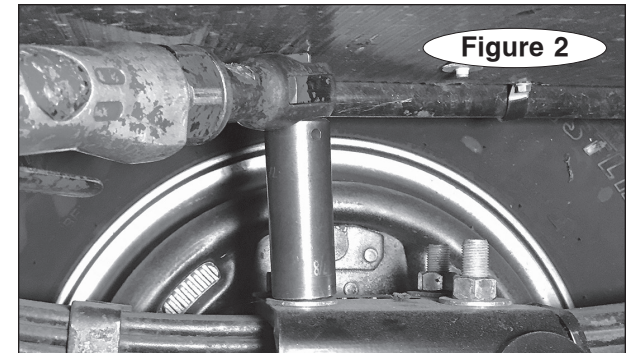

continued from preceding page

c. Position a center punch or similar device on the end of the bolt and hammer the center punch to drive the bolt out.

Note: You will be reusing these bolts. For that reason, don't hammer directly on the end of the bolt, or you will deform the threads.

d. Repeat for the other side of the trailer.

6. Remove the leaf springs and the equalizer assembly.

7. Ensure that the center equalizer hanger flanges are straight and vertical. If necessary, bend them (Figure 4).



Figure 4

8. Installing the slipper spring box:

a. Insert one of the included 2" pipe spacers between the flanges of the center equalizer hanger (Figure 5).

b. With the sticker (Figure 6) facing the outside of the trailer, slide the slipper spring box up and over the equalizer hanger bracket. Align the central slotted hole on the slipper spring box to the hole in the equalizer hanger bracket.

c. The slipper spring box must sit flush against the bottom of the frame. Check for obstructions such as underbelly material, plumbing, etc. and remove or reposition them.

Note: If it's necessary to trim underbelly material, use a utility knife and apply repair tape or other sealing product approved by the trailer manufacturer to seal the cut.

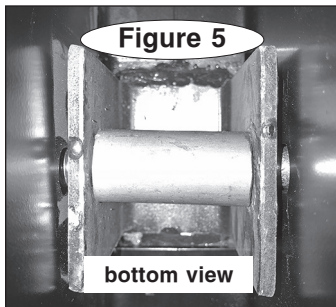

Figure 5

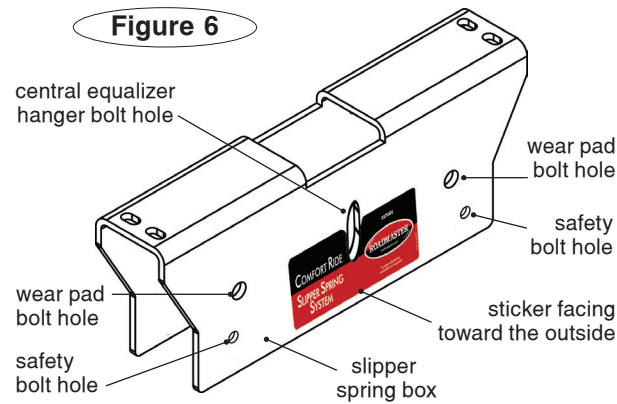

Figure 6

d. Position a 9/16" flat washer over one of the included 9/16" x 4" bolts and insert it through the central hole in the slipper spring box and the 2" pipe spacer. On the opposite side of the slipper spring box, finish with another 9/16" flat washer and 9/16" nylock nut. Leave loose at this time.

Figure 7 shows the slipper spring box.



Figure 7

9. Align the slipper spring box so that it is in line with the trailer's frame rail and centered underneath the frame rail.

Using the pre-existing holes in the top of the slipper spring box as templates, mark and drill four 21/64" diameter holes through the frame rail (Figure 8).

Tech tip: Start your first hole with a small self-drilling screw rather than a drill bit. Use the screw to keep the slipper box centered and properly aligned while you drill the rest of the holes. Don't forget to replace it with one of the included 3/8" self-tapping screws once all the holes have been drilled (step 10).

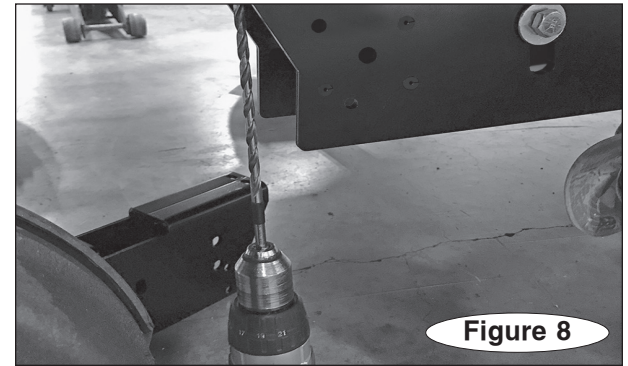

Figure 8

10. Use four of the included 3/8" self-tapping screws to attach the slipper spring box to the frame using the holes you just drilled. Use threadlocker on the screws; tighten to 40 lb-ft.

CAUTION

Do not over torque the screws or they may fail, causing the slipper spring box to separate from the frame. This may cause severe non-warranty damage if the trailer is being towed; other consequential, non-warranty damage may also occur.

11. Repeat steps 6 through 10 for the opposite side.
12. Installing the new slipper springs (refer to Figure 6 for the bolt locations in steps 12 and 13):

a. Insert the eyelet end of the spring between the flanges of the spring hanger, and reinstall the bolt you removed in step 5 (Figure 9). Drive the bolt home using a hammer to fully re-engage the splines.

continued on next page

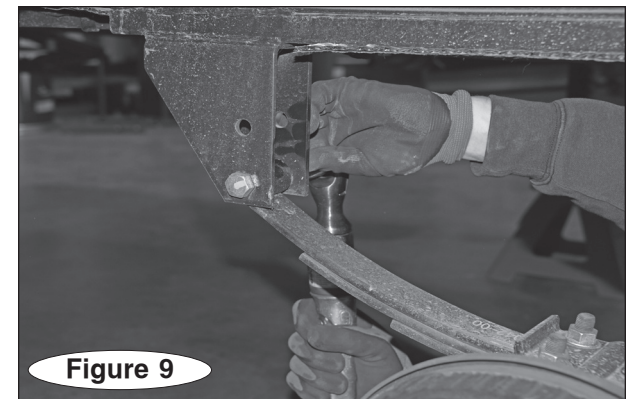

Figure 9

continued from preceding page

b. Using a cleaner/degreaser, clean and dry the threads on the end of the bolt. Apply Loctite® Red (not included) before proceeding to 12c.

c. Reinstall the nut on the spring hanger bolt.

WARNING

The spring bolts must be tightened so that the spring hanger hole rides on the shoulder of the bolt. If the spring hanger hole rides on the threads, the bolt will eventually fail causing severe, non-warranty damage.

The most common axle manufacturers' torque specifications are provided at the end of these instructions. Tighten the bolt to these specifications.

Ensure that the spring can still pivot freely inside the hanger.

d. Repeat for all other springs on the trailer.

Note: The slipper ends of each spring are always inside the slipper spring box; the spring eyelets don't go inside the slipper spring box.

13. Installing the safety bolts:

a. Pivot the slipper spring up until it's inside the slipper spring box. Move the slipper end until both ends of the spring are approximately level with each other.

b. Insert a 7/16" bolt through the safety bolt hole (refer to Figure 6), a 2½" pipe spacer, and then through the other side of the slipper spring box.

The slipper spring should now be resting on the pipe spacer (Figure 10).

Finish with a 7/16" nylock nut and torque to 40 lb-ft.

Before proceeding, torque the central 9/16" bolt and nut you installed in step 8d to 54 lb-ft.

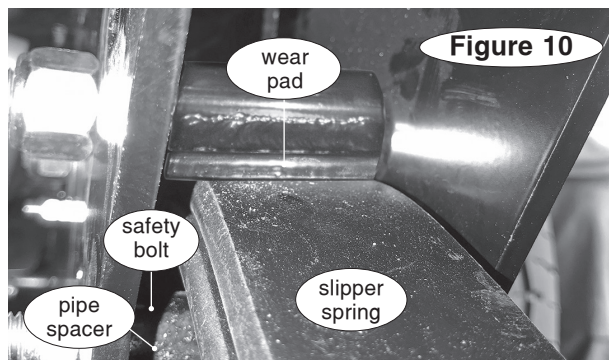

c. Repeat steps 12 and 13 for all other springs on the trailer.

14. Installing the wear pads (Figure 10):

a. Use the wear pad bolt hole for mounting the wear pad (Figure 11).

b. Position the wear pad inside the slipper spring box and insert a 9/16" x 4" bolt through the wear pad bolt hole, through the wear pad, and then out the other side. Finish with a 9/16" nylock nut. *Note: When positioned correctly, the wear pad will be above the end of the leaf spring. The spring will contact the wear pad once the suspension is loaded (Figure 10).*

Torque the bolt to 54 lb-ft. Don't overtighten the bolt but ensure that the wear pad still moves freely.

c. Repeat step 14 for the three remaining wear pads.

15. Install the Comfort Ride Shock Absorbers:

a. Position the tie plate so that the alignment pin on the leaf spring engages the center hole in the tie plate (Figures 12 and 13). Ensure the shock mounting flange faces toward the center of the trailer and is po-

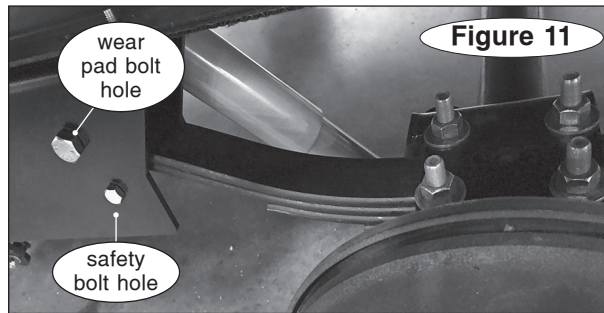

sitioned between the axles. Refer to the drawing on page 1 to better understand how the parts attach to each other.

b. Reinstall the U-bolts through the tie plate. If space allows, use the original factory tie plate that you removed in step 4c over the top of the new tie plate. This will add additional strength to the assembly. Install washers and finger tighten the U-bolt nuts.

IMPORTANT! When installing the tie plates, position the axle so that the alignment pins (shown in green, Figure 13) are seated against the tie plate (top view, Figure 13). Verify that it is the same on both sides AND on both axles. Failure to align the pins in this manner may result in an out-of-alignment axle, causing non-warranty tire wear.

Once the axle is positioned as described above, torque all U-bolts and nuts using the axle manufacturer's specifications at the end of these instructions.

continued on next page

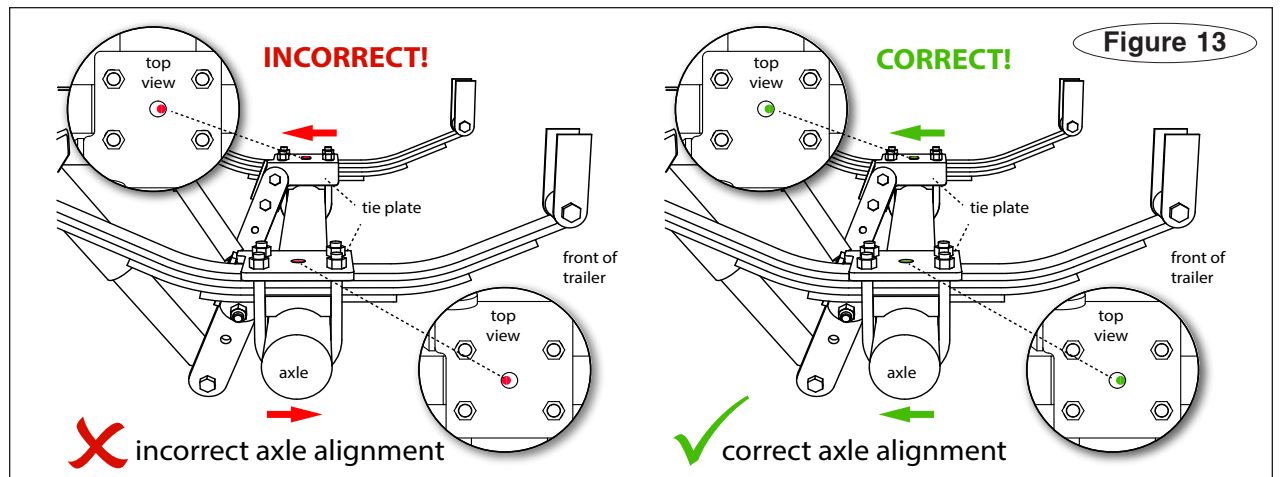
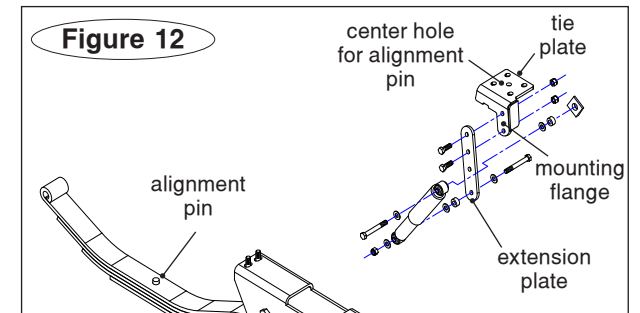

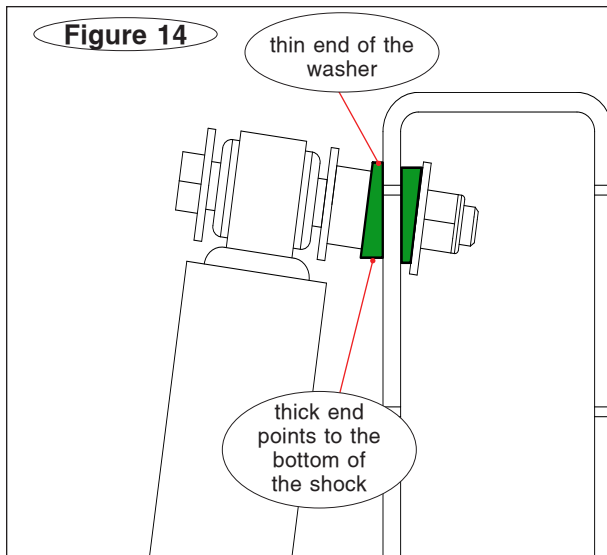

continued from preceding page

- c. Repeat this process for all tie plates and U-bolts.
- 16. Reinstall the wheels and tires, remove all jack stands and lower the trailer to load the suspension.
Note: If the trailer has the Correct Track system, check to see if it needs adjustment to align the axles after this installation.

CAUTION

Ensure the suspension is fully loaded, i.e., bearing the weight of the trailer, before installing the shock absorbers. Otherwise, the shock absorbers will be the wrong length once installed. The shock absorbers and trailer may be damaged. Other collateral, non-warranty damage may also occur.

- 17. Installing the shock absorbers to the slipper spring boxes (Figure 14):
 - a. Place a 12mm washer over a 12mm x 1.75 x 100mm bolt. Bolt through the top of the shock absorber, 12mm washer, a spacer, wedge washer (in green) and the slipper spring box. *Note: The wider portion of the shock absorber body should point to the top.*
 - b. Finish with another wedge washer (in green), 12mm flat washer and 12mm nylock nut.
 - c. Tighten the 12mm bolt and nut just enough so

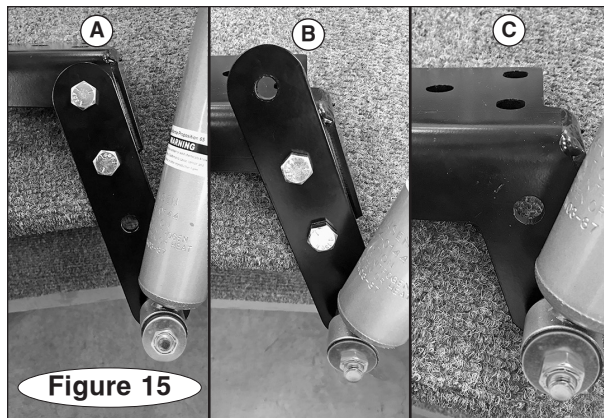

that the wedge washers will stay in place when you rotate them. (The wedge washers will be rotated, and the shock mounting bolts torqued, in a later step).

- d. Repeat for the remaining shock absorbers.
- 18. Mounting the shock absorbers to the mounting flanges or extension plates:
 - a. The purpose of the restraining bands on the shock absorbers is to hold them at a fixed length. This length will dictate where the bottom of the shock absorbers should be fastened.

Note: If the restraining bands are damaged or cut, restrain the shock absorbers at a 14½" length, hole-center to hole-center.

CAUTION

The shock absorbers must be restrained at a 14½" length, as described above, in order to position the frame brackets correctly. Otherwise the shock absorbers will break. Other consequential, non-warranty damage may also occur.

While holding the bottom of a shock absorber to the mounting flange or extension plate, determine which option shown in Figure 15 places the bottom of the shock absorber closest to a mounting hole. *Note: If the pre-drilled options do not align, use the shock absorber as a template and drill a new hole to accommodate it. IMPORTANT! Ensure that any hole you drill is at least ½" away from any other hole.*

Ensure that the angle of the shock is between 20 and 40 degrees (Figure 16).

CAUTION

Make sure the shock absorber extension plate doesn't extend below the level of the wheel rim. If it does, the plate or the shock absorber could be damaged in the event of a flat tire. Other consequential, non-warranty damage may also occur.

continued on next page

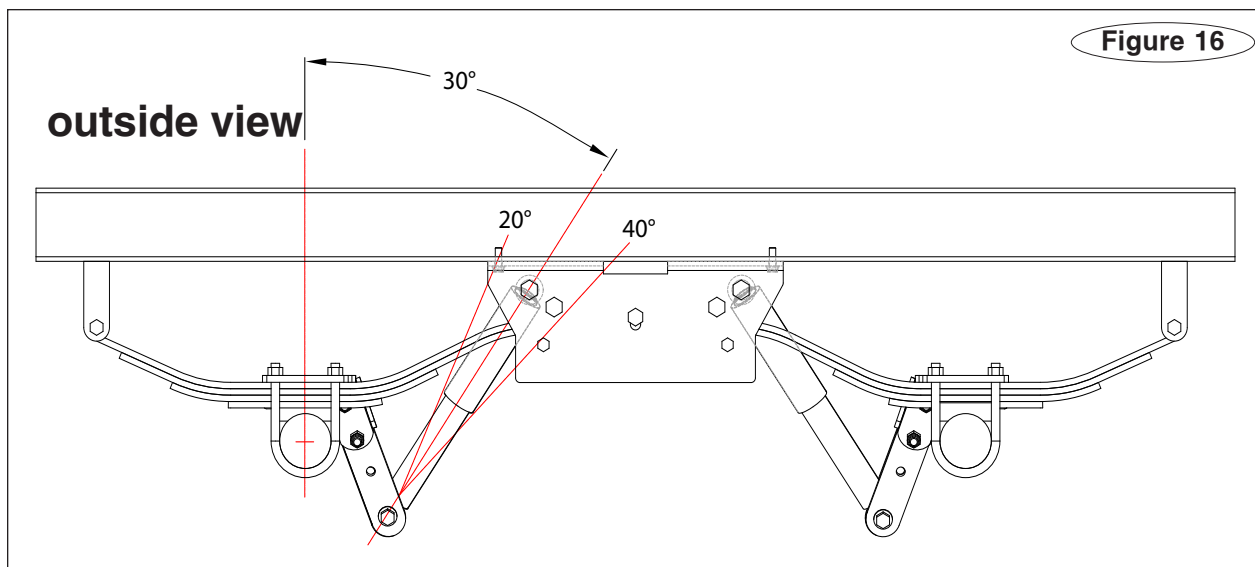

continued from preceding page

b. Position a 12mm washer over one of the included 12mm x 1.75 x 100mm bolts. Bolt through the extension plate, a spacer, 12mm washer and the bottom of the shock absorber. Finish with another 12mm washer and a 12mm nylock nut. Leave loose at this time.

c. Repeat for the remaining shock absorbers.

19. Referring to the drawing in Figure 14, verify the wedge washer orientation:

a. On the **INSIDE** of the slipper box, rotate the wedge washer so that the thin end points **DOWN, in line with the body of the shock.**

b. On the **OUTSIDE** of the slipper box, rotate the wedge washer so that the thick end points **DOWN, in line with the body of the shock.**

NOTE

The wedge washers provide a flat surface for mounting the shock while spacing the shock away from the slipper spring box.

continued from preceding page

CAUTION

If the wedge washers aren't positioned as described above, the shock absorbers may be damaged. Other collateral, non-warranty damage may also occur.

c. Tighten all top and bottom shock absorber mounting bolts to 55 lb-ft. Now, remove the restraining bands from the shock absorbers.

Re-check the torque of all fasteners. All bolts should be tight.

Torque Values for U-Bolts

These torque charts are furnished by the manufacturers of the most common axles in production. While these charts were correct at the time of publication, specifications may change without notice.

Dexter Axles

<i>Item</i>	<i>Torque Range (ft-lb)</i>
3/8" U-bolt	30-50
7/16" U-bolt.....	45-70
1/2" U-bolt with hex nut	45-70
1/2" U-bolt with flange nut	70-80
9/16" U-bolt	65-95

Lippert Axles

2,000- to 8,000-pound capacity axles

Bolt Type

Torque Specification (ft-lb)

U-bolts (2,000 lb axle)	35
U-bolts (3,500 lb axle with 1/2" U-bolts).....	50
U-bolts (5,000 lb axle)	65
U-bolts (6,000-8,000 lb axles).....	90

Rockwell American Axles

Bolt Type

Torque (ft-lb)

3/8" U-bolt	30-50
7/16" U-bolt.....	45-70
1/2" U-bolt.....	45-70
9/16" U-bolt.....	60-85

