



Time Tested • Time Proven

856180-00 11.20

# Bulb and socket kit

part number 155

## Installation Instructions

All specifications are subject to change without notice.

ROADMASTER, Inc. • 6110 N.E. 127th Ave. • Vancouver, WA 98682 • 800-669-9690 • Fax 360-735-9300 • roadmasterinc.com

### WARNING

Read all instructions before installing the kit components. Failure to understand how to properly install the kit could result in property damage, personal injury or even death.



### Before you begin the installation...

- This kit uses four-prong connectors to conduct lighting signals from the motorhome to the towed vehicle. If you would prefer electrical sockets at both vehicles, optional kits with sockets, mounting brackets and straight or Flexo-Coil™ electrical cords are available from ROADMASTER.
- If the motorhome has separate brake and turn signals (Figure 1), an optional Brite-Lite™ 3-to-2 wiring converter is required.

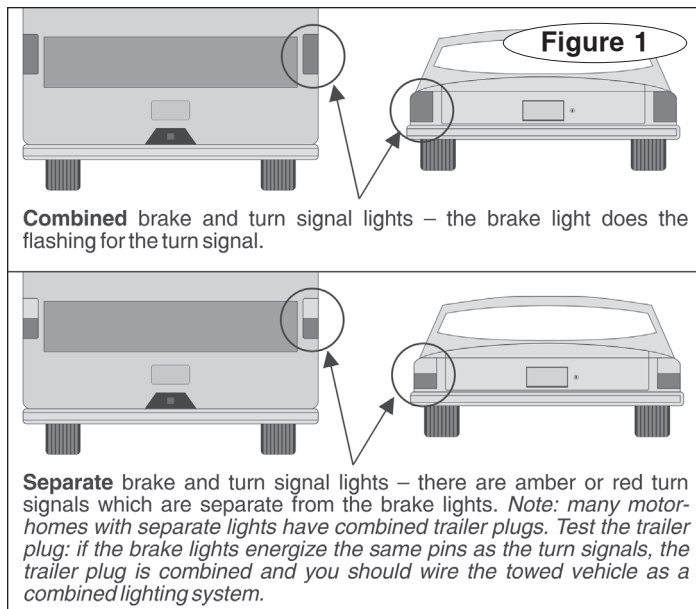

Installation instructions for these accessories are included with the kits.

*Note: if the motorhome has a separate lighting system, a 3-to-2 converter must be installed in order to use this kit. A 3-to-2 converter converts a separate system to a combined system.*

*Many late-model motorhomes come with converters already installed – test for this before installation: if the motorhome's trailer plug energizes the same pins for both brake lights and turn signals, then a 3-to-2 converter is already installed and the motorhome should be treated as combined.*

*If a converter is needed, install ROADMASTER's Brite-Lite™, part number 732.*

### Required Tools

- 1" hole saw or rotary cutting tool
- drill
- wire stripper
- wire crimper
- test light

### Installation Instructions

1. You will attach one end of the wiring harness to the taillight assemblies, then route the other end of the harness to the front of the vehicle.

Before you attach the wiring harness, plan a route to the front of the vehicle. Choose a route that avoids the possibility of fraying or melting the wiring against moving parts, sharp edges, the fuel lines or hot components. (If the OEM wiring harness is accessible, consider routing the harness alongside it.)

### WARNING

**Plan a route that will avoid moving parts, sharp edges, the fuel lines or hot components such as the engine or exhaust system.**

**Wiring exposed by moving parts, sharp edges or hot**

*continued on next page*

### IMPORTANT NOTICE!

#### Safety Definitions

These instructions contain information that is very important to know and understand. This information is provided for **safety** and to **prevent equipment problems**. To help recognize this information, observe the following symbols:

### WARNING

**WARNING** indicates a potentially hazardous situation which, if not avoided, could result in property damage, serious personal injury or even death.

### CAUTION

**CAUTION** indicates a potentially hazardous situation which, if not avoided, may result in property damage, or minor or moderate personal injury.

### CAUTION

**CAUTION** used without the safety alert symbol indicates a potentially hazardous situation which, if not avoided, may result in property damage.

### NOTE

*Refers to important information and is placed in italic type. It is recommended that you take special notice of these items.*

continued from preceding page

**components may cause a short circuit, which can result in damage to the vehicle's electrical system as well as other, consequential damage.**

**Wiring which is attached in close proximity to the fuel lines may ignite the fuel.**

2. Look for a location to mount the bulb sockets inside the taillight housings. The mounting point should be as flat as possible, and must meet the following conditions: 1) the bulb sockets must be installed underneath red lenses; and 2) there must be at least ¼" clearance between the bulbs and the lenses.

**! WARNING**

**Install the bulb sockets underneath red lenses. If the sockets are installed under amber or clear lenses, drivers behind the towed vehicle will not be alerted when the motorhome stops, which may cause a collision.**

**CAUTION**

**Unless there is at least ¼" of clearance between the bulb and the lens, the lens will melt and/or discolor.**

3. If it will be necessary to drill a hole to route the wiring, drill the hole now.

Cut one of the four-wire flats from the wiring harness, leaving three feet of the harness attached. (You may use this section later at the motorhome.)

Route the cut end of the harness through the hole so that the other end of the harness, with the four-wire flat, can be routed to the front of the vehicle.

4. Expose the wires behind both taillight assemblies. (It may be necessary to remove the taillight assemblies from the exterior of the vehicle to gain access.)

5. Drill one-inch circular holes through the back of the taillight housings at the mounting points you have selected.

The holes must be circular, in order to hold the sockets in place. A hole saw works best, but the shape and location of some taillights may require a rotary cutting tool.

**! WARNING**

**Be certain not to cut into any wires or other components. Severe electrical damage or injury may result.**

6. Bend the spring-loaded tabs that encircle the sockets outward slightly, then snap the bulb sockets into the holes.

If the tabs are not bent, road vibrations will cause the sockets to fall out of the holes. For this reason, make certain the sockets are securely attached before continuing.

*Note: if one of the holes is not completely circular, bend one or more of the tabs farther to accommodate the shape of the hole.*

7. Use the butt connectors to attach the four-wire electrical harness to the sockets. Figure 2 is ROADMASTER's recommended wiring schematic.

Attach the appropriate wires to either one of the sockets. Then separate the wires, peel back the appropriate wire(s) to the other side and attach them in the same manner.

*Note: use the larger yellow connectors for two-wire*

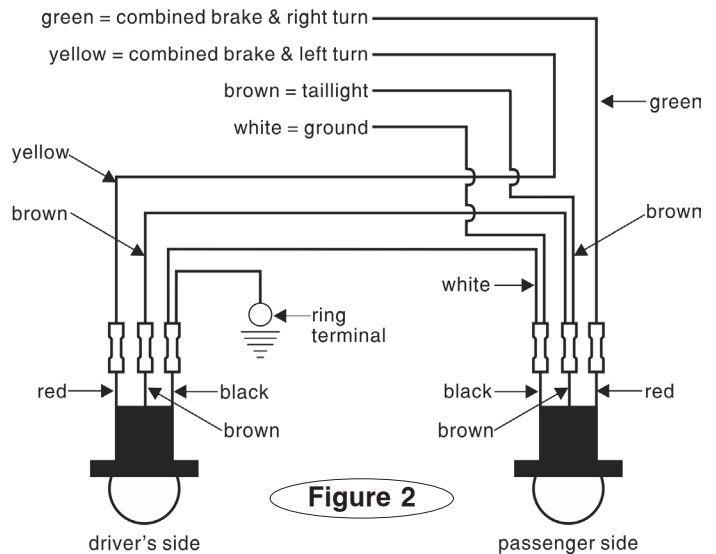

Figure 2

connections; use the smaller blue connectors for single-wire connections.

8. Use one of the included ring terminals and the self-tapping screw to ground the towed vehicle, as shown in Figure 2.

To avoid grounding problems, attach the wire to any good chassis ground, preferably directly to the frame.

**CAUTION**

**Failure to establish a good ground between the towed vehicle and motorhome could cause aftermarket accessories to malfunction, damage to both vehicle's electrical systems, and other consequential damage.**

9. Route the other end of the wiring harness to the front of the vehicle, using the route you planned in step 1. Where appropriate, use a section of the included split loom to protect the wires; use one or more of the included wire ties to secure the wiring in place.

10. If it was necessary to drill a hole to route the harness, seal the hole with silicone sealant after you have run the harness through.

11. After you route the wiring harness to the front of the vehicle, choose a mounting point for the four-wire flat. Look for a mounting point near the center, away from pre-existing components, with a surface of sufficient strength to hold it firmly in place.

**CAUTION**

**The four-wire flat must be mounted near the center. If it is attached too far to either side, it may be damaged or pulled away when the motorhome turns.**

12. Use one of the included wire ties to attach the four-wire flat. Allow enough slack so that it can easily be connected and disconnected from the matching male connector on the six-foot power cord.

13. Choose an attachment point at the rear of the motorhome for the three feet of electrical harness and the female connector you removed in step 2. Look for a mounting point

continued on next page

*continued from preceding page*

away from pre-existing components, close to the center.

*Note: attach the connector close to the center. If the harness is attached too far to either side, it may be pulled away when the motorhome turns.*

**14.** Attach the connector with one of the included wire ties. Allow enough slack so that it can be easily connected and disconnected from the matching male connector on the six-foot power cord.

**15.** With a test light, identify the wires conducting the brake, turn signal, taillight and ground signals from the motorhome. Use butt connectors (not supplied) to connect the appropriate wires to the section of electrical harness.

Use a second ring terminal (not supplied) to ground the motorhome, preferably directly to the frame.

**16.** Connect the power cord to the motorhome and towed vehicle. Test to make certain that the towed vehicle's turn signals, taillights and brake lights operate in conjunction with those of the motorhome.