



Time Tested • Time Proven

856299-02 11-23

# Stinger replacement kit

Part Number 910520

## Installation Instructions

All specifications are subject to change without notice.

ROADMASTER, Inc. 6110 NE 127th Ave. Vancouver, WA 98682 800-669-9690 Fax: 360-735-9300 www.roadmasterinc.com

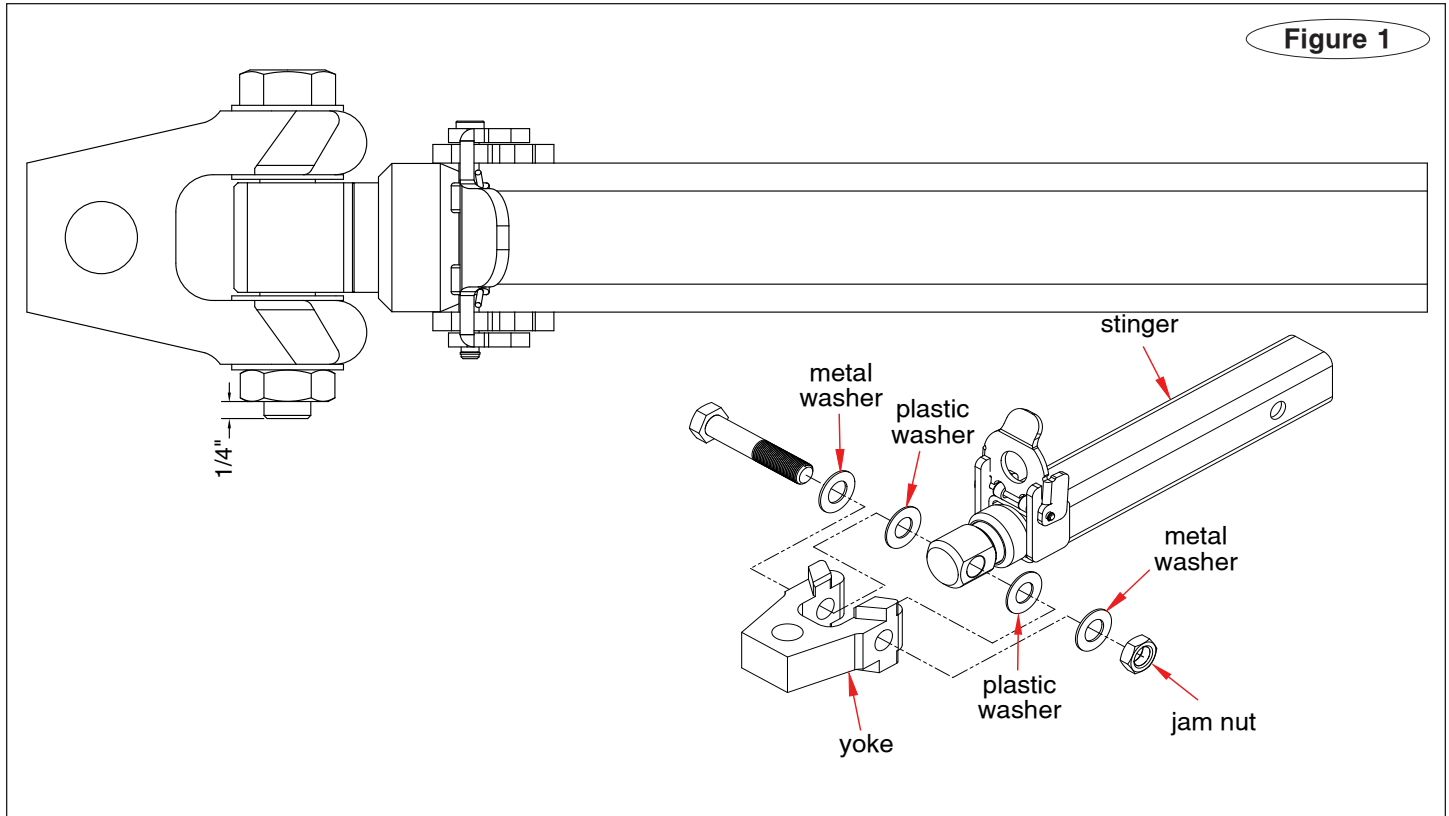

### WARNING

Read the instructions before installing the kit components. Failure to follow these instructions may result in property damage, serious personal injury or even death.

#### Kit components

This kit contains the components to replace the stinger on your Nighthawk or Sterling All Terrain tow bar.

- (2) plastic washers
- (1) stinger assembly
- (1) jam nut

You will retain the 3/4" x 3" bolt and 3/4" metal flat washers from the existing stinger and yoke on the tow bar.

#### Required tools

- (2) 1-1/8" wrenches or sockets

#### Installation instructions

1. Remove the bolt that secures the stinger to the yoke. Retain the 3/4" metal flat washers and the 3/4" x 3" bolt, as they will be used to install the new stinger.
2. Loosely assemble the new parts using Figure 1 above as a reference. *Note: The plastic washers fit between the yoke and the stinger while the metal washers go on the outside of the yoke.* Make certain you use the new jam nut. Re-use of the old jam nut may result in failure.
3. Tighten the jam nut. There should be approximately 1/4" of thread beyond the jam nut. The stinger should still pivot but with resistance.