



TOWING & SUSPENSION SOLUTIONS



Time Tested - Time Proven
800-669-9690
roadmasterinc.com



The ROADMASTER Difference - Since 1970

ROADMASTER strives to keep all of our processes right here in the USA. We are proud of our diverse group of craftspeople and support staff at our Vancouver, WA and Portland, OR facilities who transform raw steel, aluminum, and brass into the finest towing and suspension equipment available.



The Basics of Towing... What to Know Before

There are four major components to any towing system: **1** the tow bar, **2** the baseplate, **3** the braking system, and **4** combo kits and accessories. ROADMASTER designs, tests and manufactures products to make every aspect of your towing experience safe and pleasurable.

1 Tow Bar

CONNECTING YOUR VEHICLE AND RV



The tow bar is the secure link between your towed vehicle and motorhome. A tow bar is by far the most common method of towing. It allows for the quickest connection to the motorhome; plus, it's lightweight, easy to handle and simple to store.

3 Braking System

STOPPING POWER FOR SAFETY



Supplemental brakes are required in most states, and for an excellent reason — the laws of physics. Supplemental braking systems are designed to stop the towed vehicle-motorhome combination in about the same distance as the motorhome alone.

Our Promise to You

- Superior customer service. Superior products.
- Unsurpassed strength through computerized and physical testing.
- Easiest-to-use, longest-lasting, and most trouble-free.
- The leader in tow bar innovation — visit roadmasterinc.com/patents
- A true American manufacturer
- All products covered by a limited-lifetime warranty

You Tow

IMPORTANT — Before towing any vehicle, consult your owner's manual to be sure your vehicle can be towed with all four wheels on the ground without damage to the transmission. Some vehicles can be towed as is, but others may require a transmission lube pump system or driveshaft disconnect.

If your vehicle cannot be flat towed, consider a tow dolly (see PAGE 41).

2 Baseplate *STRONG & HIDDEN*



The strongest connection between your tow bar and your vehicle. Designed specifically for each vehicle model.

4 Combo Kit *EVERYTHING YOU NEED*



When towing a vehicle behind your RV, you're going to need some things. Our tow bar combo kits are put together specifically for each tow bar we produce.

CONTENTS

TOW BARS & BASEPLATES	1-8
Nighthawk®	1
Falcon 2®	2
StowMaster® & Tracker®	2
Sterling® All-Terrain.....	3
Falcon® AT & Blackhawk® 2 AT	4
Baseplates	7-8
SUPPLEMENTAL BRAKING SYSTEMS	9-18
Overview	9-10
InvisiBrake®	11-12
Even Brake®	13
BrakeMaster®	14
Second Vehicle Kits.....	15
Second Motorhome Kits	15
Braking Accessories.....	16-18
TOWING ACCESSORIES	19-32
Combo Kits & Safety Cables.....	19-20
Towed Vehicle Wiring Kits	21
Electrical	22-25
Covers.....	26
Vehicle Protection.....	27
Tow Bar Adapters.....	28-29
Pins & Clips	30
Hitch Accessories	31
Spare Tire Carriers.....	32
SUSPENSION & HANDLING	33-40
Overview	33-34
Anti-Sway Bars.....	35
TruTrac® Bars	36
Reflex Steering Stabilizer	37
Exact Center® Steering Stabilizer	38
Trailer & 5th Wheel Suspension	39-40
OTHER PRODUCTS	41-46
Tow Dolly.....	41
Care & Cleaning.....	42
Hoses & Wheel Covers.....	43-45
Trailer Equipment.....	45-46

TOW BARS & BASEPLATES

ADVANCED DESIGN
STRONGEST AND LONGEST



The World's Only Illuminated Tow Bar

The Nighthawk is a non-binding, aluminum alloy tow bar designed exclusively for ROADMASTER's direct-connect baseplates (see PAGE 7), with the longest tow bar arms ever produced, for maximum stability and better towing characteristics.

The Nighthawk is a clean, sleek looking tow bar. Unique to the Nighthawk is a dazzling row of amber LEDs along each tow bar arm that illuminate with the motorhome's lights. The 300-lumen LEDs add safety and convenience to nighttime towing — what was the darkest portion of the towing system is now easily visible to other drivers. The LEDs provide ample lighting for hooking up in the dark.



Mounts to:	Motorhome
Capacity:	8,000 lbs
Weight:	35lbs
Length:	57 in
Safety / Power Cables & Plugs	Included
Receiver Hitch Size:	2 in

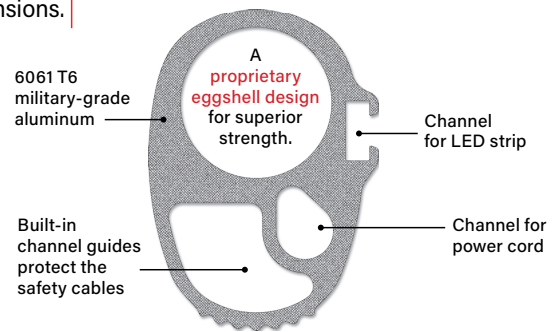

NIGHTHAWK

Nighthawk Tow Bar	676
Nighthawk Tow Bar - fits Blue Ox baseplates (not shown)	677
Nighthawk Combo Kit - the accessories you need, matched to your Nighthawk tow bar — see PAGE 19 (not shown)	9284-2



Falcon 2[®]

Autowlok[®] System

Storage Latch

Mounts to:	Motorhome
Capacity:.....	6,000 lbs
Weight:.....	38lbs
Length:.....	56in
Receiver Hitch Size.....	2 in

A. FALCON 2 - 520

A. FALCON 2

- Stainless steel in virtually every moving component for smooth, trouble-free operation.
- Autowlok[®] locking mechanism — allows both tow bar arms to extend or retract for a quick connection. Drive away and the arms self-center and automatically lock.
- Easily connect/disconnect the Falcon 2 in seconds.
- A lustrous powder-coat finish for maximum durability.

Stow and go

In the folded position, the Falcon 2 conveniently stores out of the way on the back of your motorhome. A tow bar cover (055-3 - sold separately) keeps your tow bar clean.

Easy-to-use!

One person can easily connect or disconnect the Falcon 2 in seconds.

Falcon 2 Tow Bar..... 520

Falcon 2 Tow Bar - fits Blue Ox baseplates (not shown)..... 525

Falcon 2 & StowMaster Release Tool - aids in unlocking tow bar arms when bound (not shown) 066



STOWMASTER[®]

StowMaster pintle ring

Mounts to:	Car
Capacity:.....	6,000 lbs
Weight:.....	38 lbs
Length:.....	47 in

B. STOWMASTER - 501 - 581

B. STOWMASTER

- Stainless steel in virtually every moving component for smooth, trouble-free operation.
- Autowlok locking mechanism — allows both tow bar arms to extend or retract for a quick connection. Drive away and the arms self-center and automatically lock.
- Self-lubricating nylon bushings eliminate friction between the arms. Other manufacturers use steel on steel.
- Plug-welded arms — steel plugs seal both ends of the tow bar, preventing corrosion from moisture and debris.
- Full-length, steel crossbar for maximum support.
- A lustrous powder-coat finish for maximum durability.
- Easily folds to car for compact storage.

StowMaster tow bar - 2" coupler..... 501

StowMaster tow bar - 2⁵/₁₆" coupler..... 504

StowMaster tow bar - 2¹/₂" pintle ring 581

StowMaster tow bar - 3" pintle ring 583



TRACKER[®]

Mounts to:	Car
Capacity:.....	5,000 lbs
Weight:.....	38 lbs
Length:.....	44 in

C. TRACKER - 020

C. TRACKER

The safest, strongest, easiest, most durable, trouble-free, 5,000-lb. rated, rigid A-frame tow bar manufactured...BAR NONE! Arms hinge together for storage.

Tracker tow bar fits standard 2" ball..... 020

Note: Optional set of quick-disconnects (part number 201) is necessary to remove the front baseplate arms.

Note: Will not fit 'direct-connect' style baseplates.



Length, Strength, and Stability

The Sterling All-Terrain was designed, tested and manufactured to the highest standards. The Sterling is a non-binding, aluminum alloy tow bar designed exclusively for ROADMASTER's direct-connect baseplates (see PAGE 7), with longer tow bar arms for maximum stability and better towing characteristics.

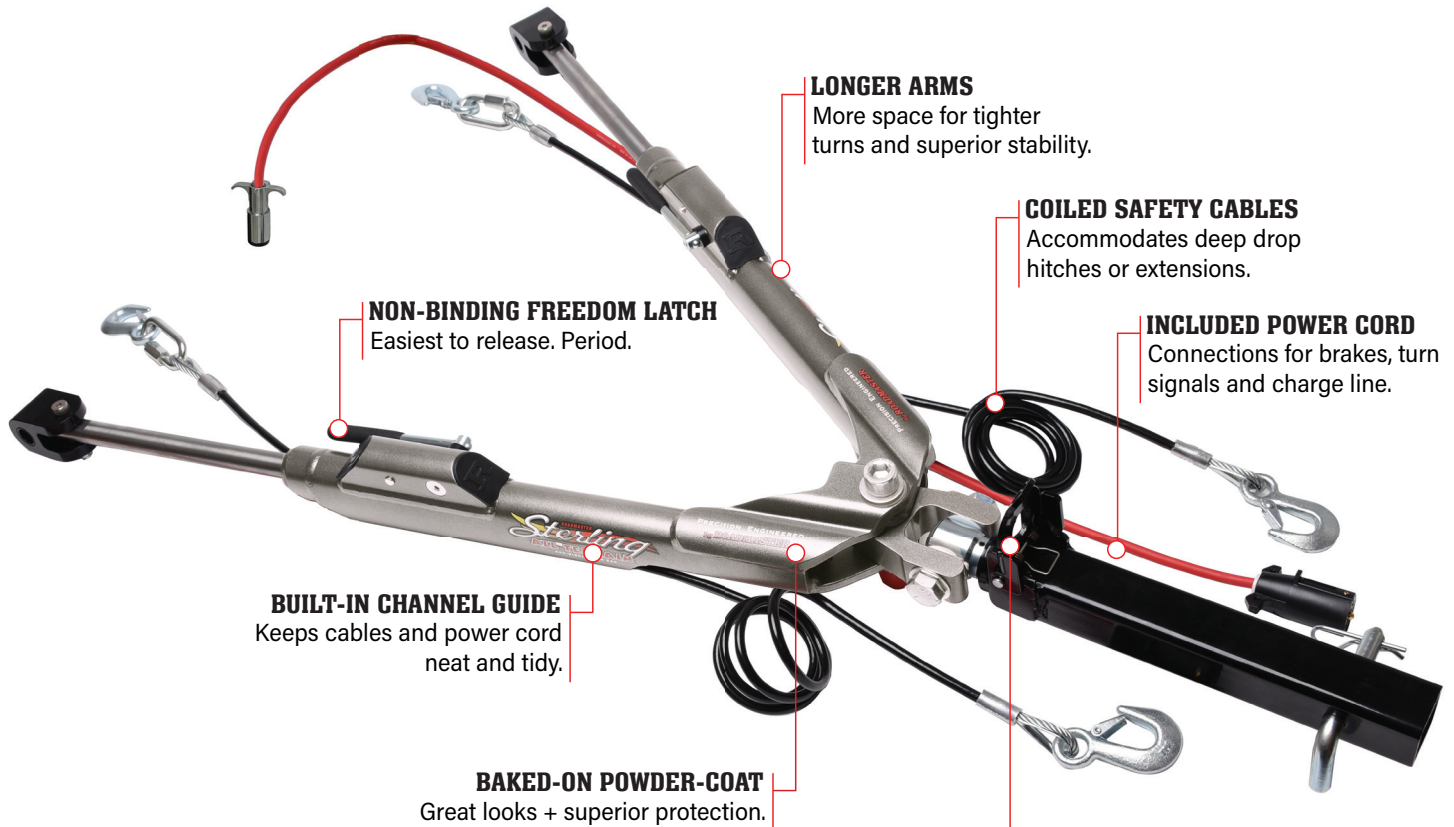

LONGER ARMS

More space for tighter turns and superior stability.

COILED SAFETY CABLES

Accommodates deep drop hitches or extensions.

INCLUDED POWER CORD

Connections for brakes, turn signals and charge line.

NON-BINDING FREEDOM LATCH

Easiest to release. Period.

BUILT-IN CHANNEL GUIDE

Keeps cables and power cord neat and tidy.

BAKED-ON POWDER-COAT

Great looks + superior protection.

ONE STEP STORAGE LATCH

Easily fold and stow - automatically clicks into place.

6061 T6 military-grade aluminum

A proprietary eggshell design for superior strength.

Built-in channel guides protect the safety cables and power cord

Mounts to:	Motorhome
Capacity:	8,000 lbs
Weight:	35lbs
Length:	56 in
Safety / Power Cables & Plugs	Included
Receiver Hitch Size:	2 in

STERLING ALL-TERRAIN

Sterling All-Terrain Tow Bar	576
Sterling All-Terrain Tow Bar fits Blue Ox baseplates (not shown).....	586
Sterling All-Terrain Combo Kit the accessories you need, matched to your Sterling All-Terrain tow bar — see PAGE 19 (not shown).....	9284-2

ALL-TERRAIN

Exclusive Features

- One-step storage latch**
 Fold the tow bar toward the motorhome and it will “click,” automatically locking in place.
- Built-in channel guides**
 Cables and power cord route through built-in channel guides for a clean look and protection against damage.
- Solid stainless steel inner arms**
 For smooth, trouble-free operation and easy maintenance. Stainless steel looks better, lasts longer and prevents corrosion that binds — ROADMASTER tow bars are the most rust-free in the industry.
- Collapsible and Adjustable**
 Each telescoping inner arm can be extended or retracted independently. That range of motion means there’s no wasted time lining up your towed vehicle to connect it. ROADMASTER tow bars are just like horseshoes — “close” is good enough. Long arms extend the turning radius, making maneuvering in and out of gas stations and campgrounds easier.
- Metal-flake powder-coat finish is baked on**
 This finish exceeds all 500-hour salt spray, extreme weather and high-impact standards.
- Self-aligning design**
 Just hook up and drive away — the tow bar arms automatically extend, self-center and lock into position.

Freedom Latch non-binding technology

No more binding! (or skinned knuckles, or “#%#@?!”) The Freedom Latch transforms linear motion into rotary motion at a 400-to-1 ratio — 5 lbs of force against the latch equals 2,000 lbs of force against the lock. Freedom Latches are non-binding for easy, trouble-free disconnects.

- A. FALCON® ALL-TERRAIN**
 Simple. Durable. Non-Binding.
Falcon All-Terrain Tow Bar **522**
Falcon All-Terrain Tow Bar - fits Blue Ox baseplates (not shown) **527**
Falcon All-Terrain Combo Kit (not shown) **9243-1**

- B. BLACKHAWK® 2 ALL-TERRAIN**
 For heavy-duty, hard-core, serious towers. Same great features as the Falcon All-Terrain, but with thicker steel for a 10,000lb rating.
BlackHawk 2 All-Terrain tow bar **422**
BlackHawk 2 All-Terrain tow bar (fits Blue Ox baseplates) (not shown) **427**
BlackHawk 2 All-Terrain Combo Kit (not shown) **9243-3**

For items designed to go with your tow bar, such as combo kits and protective covers, see our TOWING ACCESSORIES section.



FALCON ALL-TERRAIN



Mounts to:	Motorhome
Capacity:	6,000 lbs
Weight:	38 lbs
Length:	56 in
Receiver Hitch Size:	2 in

A. FALCON ALL-TERRAIN - 522

BLACKHAWK 2 ALL-TERRAIN



Mounts to:	Motorhome
Capacity:	10,000 lbs
Weight:	38 lbs
Length:	56 in
Receiver Hitch Size:	2 in

B. BLACKHAWK 2 ALL-TERRAIN - 422

At-A-Glance Tow Bar Features



Nighthawk



Sterling AT



Blackhawk 2 AT



Falcon AT



Falcon 2



StowMaster



Tracker

	NIGHTHAWK	STERLING AT	BLACKHAWK 2 AT	FALCON AT	FALCON 2	STOWMASTER	TRACKER
BUILT-IN LED LIGHTING	X						
NON- BINDING FREEDOM LATCH	X	X	X	X			
COLLAPSES FOR STORAGE	X	X	X	X	X	X	X
PINLESS STORAGE LATCH	X	X	X	X	X		
BUILT-IN CABLE GUIDE	X	X	X	X			
MULTI-AXIS SWIVEL	X	X	X	X	X		
SOLID STAINLESS STEEL INNER ARMS	X	X	X	X	X	X	
MADE FROM	ALUMINUM	ALUMINUM	STEEL	STEEL	STEEL	STEEL	STEEL
POWDER-COATED FINISH	X	X	X	X	X	X	X
COMPUTER DESIGNED & TESTED	X	X	X	X	X	X	X
SAFETY & ELECTRICAL CABLES	X	X					
MADE IN THE USA	X	X	X	X	X	X	X
RV MOUNTED	X	X	X	X	X		
CAR MOUNTED						X	X
WEIGHT CAPACITY (IN LBS)	8,000	8,000	10,000	6,000	6,000	6,000	5,000



Tow Bar Testimonials

"After more than 20 years of full-time RVing, we trust our ROADMASTER tow bar to keep our car safe & secure behind our motorhome. It's built like a tank, and incredibly quick and easy to connect and disconnect at any angle. Thanks to ROADMASTER we can relax on the road with the peace of mind that comes from knowing our toad will safely follow us wherever we go!"

— P. Knize & J. Sullivan, www.thervgeeks.com

"My tow bar has served me well, above expectations, since I bought it in 1992. It has been on two motorhomes and four tow vehicles. I would highly recommend ROADMASTER."

— J. Eaton, Helena, MT

"I was parked in a truck stop with my car attached to my RV by your Sterling tow bar. A semi-trailer backed up and pushed my car onto the back bumper of my RV. When I walked back to my car, the front wheels were three feet off the ground and the tow bar was holding it up! The police officer who took my statement couldn't believe the strength of your system."

— J. Miller, Cedarville, NJ

"I sure like my Falcon 2 tow bar, and especially the tow bar bracket on my Honda CRV. It fits perfectly, and looks great."

— S. Vaughn, Jr., Kilgore, TX

"I love the ROADMASTER system. In early February this year, I worked the parking detail at the FMCA INTO Rally at Pima County Fairgrounds in Tucson. We had almost 450 rigs of all sizes and shapes. The majority had toads, so in five days of helping park RVs, I saw virtually every tow system out there... ROADMASTER, Blue Ox and some I had never heard of. Many were flat towed; some were towed with dollies; and some were towed on trailers.

We had the RVs unhook their toads prior to parking them. So I saw a ton of ways toads were hooked up. BY FAR, from what I saw, ROADMASTER was the easiest and quickest way to tow a vehicle behind an RV. I watched people unhook from other systems, stow cables and cords, and go through major issues getting their vehicles to drive. The ROADMASTER is so quick, and very reliable, and it showed at the Rally.

From a personal note, I travel full time, and alone. It takes me literally about three minutes to unhook and drive away in my Honda Fit and at the most five minutes to hook it up and be ready to tow it down the road.

I am a firm believer in your system."

— J. Fitzpatrick, Sioux Falls, SD



Award-Winning Design

ROADMASTER has been winning awards for as long as we have been making tow bars. We are truly honored and a bit tickled. For over 50 years, we have provided outstanding towing solutions.

Time-proven and robust, our tow bars stand out with innovative designs built for a wide range of applications.



BASEPLATES

HIDDEN, STRONG, AND
EASIEST TO INSTALL.

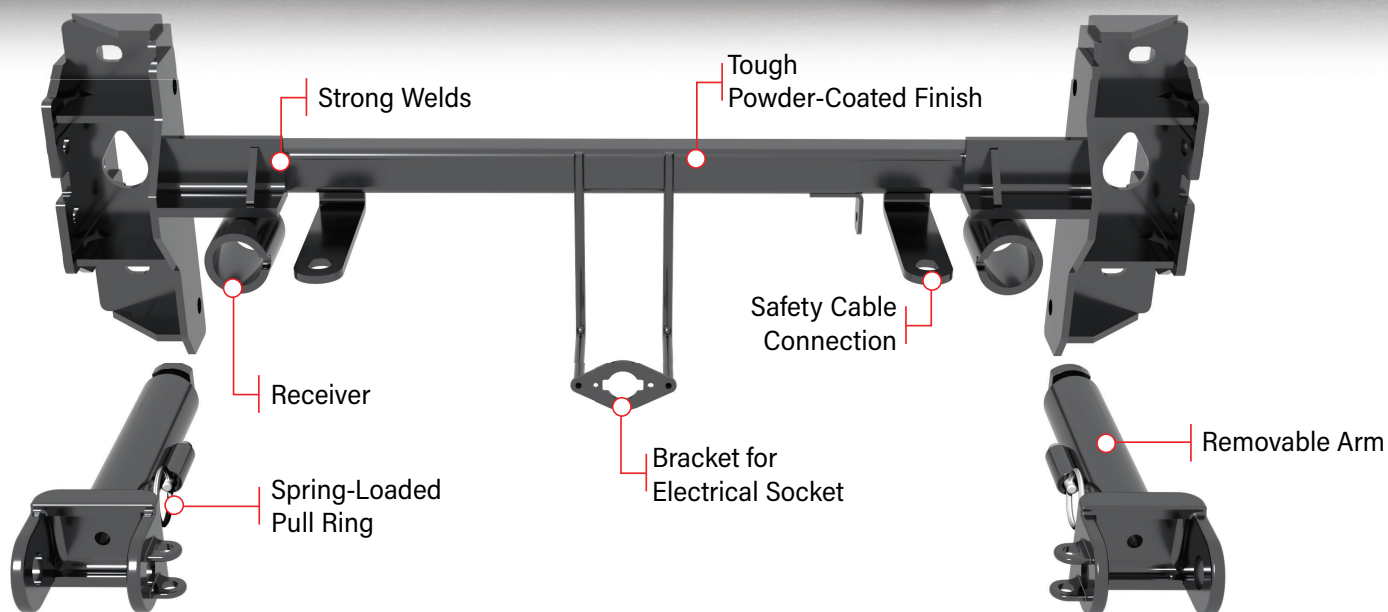

Designed and Crafted to Exacting Standards.

- A better design — our baseplates are integrated into the frame and undercarriage of the vehicle, connecting to existing holes and fasteners wherever possible, for a quick, easy installation by your local professional.

- Easier installation — our baseplates are 30 percent quicker to install, on average, than other brands — there are fewer components to unbolt or remove and fewer holes to drill.

- Computer-tested — every baseplate design is subjected to computer-simulated “Finite Element Analysis” (next page) to ensure structural integrity and maximum strength.

- Custom fit — every baseplate is custom-made to fit a specific vehicle year, make and model.

- We have the baseplate for your car — we have more than 1,000 different baseplates available (far more than any other company) — which fit nearly every towable vehicle made during the last 25 years.

- Baked-on finish — every baseplate is powder-coated. In this process, charged particles of pigment are baked into the surface of the baseplate. They fuse to the metal to form a lustrous, uniform and extremely durable finish.

Leveraging Technology, Art, & American Ingenuity

WHAT IS 'FEA?'

ROADMASTER's computerized testing method is called "FEA," which stands for "Finite Element Analysis."

Every FEA design is displayed as a full-scale, three-dimensional object, which engineers can rotate and study on the screen as they apply extreme forces across the load-bearing components. Stress in the steel is pinpointed and the design is manipulated to remove it.

The result is an optimized design, in both materials and components, which has been tested and verified at maximum linear strain — the strongest, safest and easiest-to-use baseplates in the industry.

ROADMASTER was the first towing products manufacturer to use computerized stress testing — as well as "real world" physical testing — on our tow bars and baseplates to ensure structural integrity, longevity and the safety of your family.

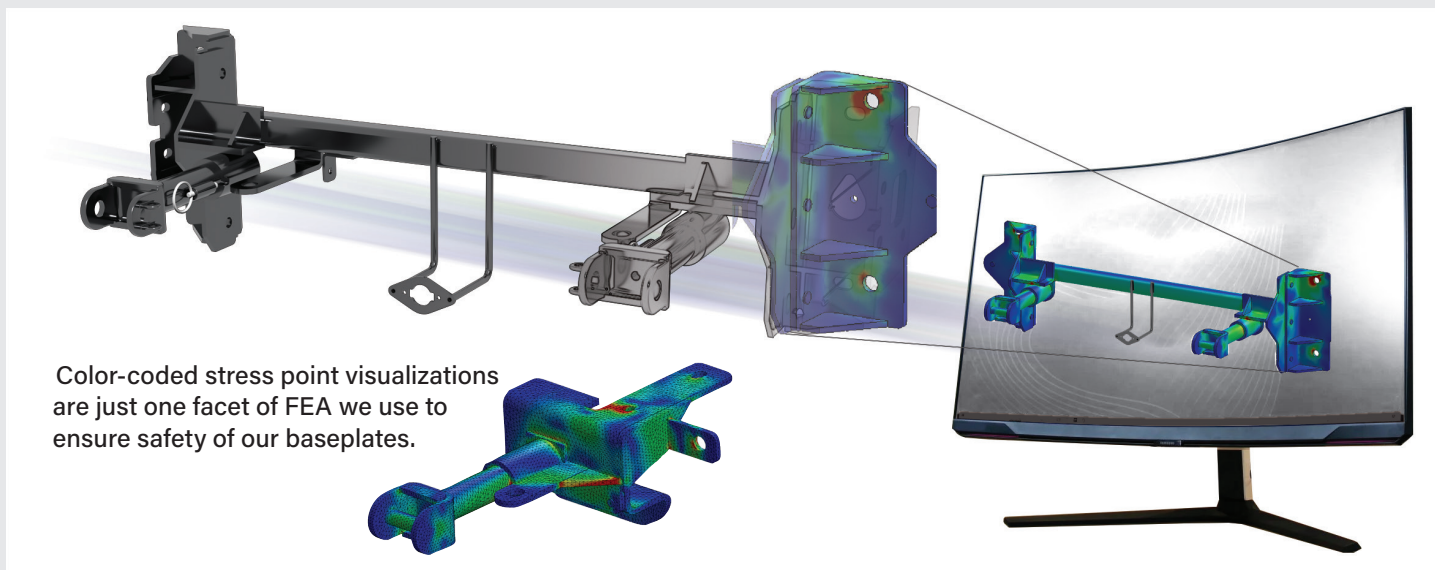

Color-coded stress point visualizations are just one facet of FEA we use to ensure safety of our baseplates.

Hidden Baseplates

All late model baseplates have been manufactured with front arms that are easily removed when the vehicle isn't being towed.



NOW YOU SEE 'EM...



NOW YOU DON'T

Designed and Crafted in the USA

Each of our baseplates is created from raw steel at our manufacturing facility in Vancouver, Washington.

Why does this matter?

ROADMASTER takes great pride in designing, testing and manufacturing our products in America.

Other manufacturers build overseas, some 'Assemble in America.' But few take their products from raw steel and craft them into finished products like we do.

Quality craftsmanship ensures a beautiful, long-lasting, safe and easy-to-use product.



FIND YOUR FIT

Scan the QR code or visit fitmaster.roadmasterinc.com and enter your vehicle's year, make and model.



Here Are 5 Reasons Why You Need Supplemental Brakes...

1 SAFETY FIRST!

Take the load off the motorhome with supplemental brakes. When the motorhome and towed vehicle brake in tandem, it takes significantly less time and distance to come to a safe, controlled stop.

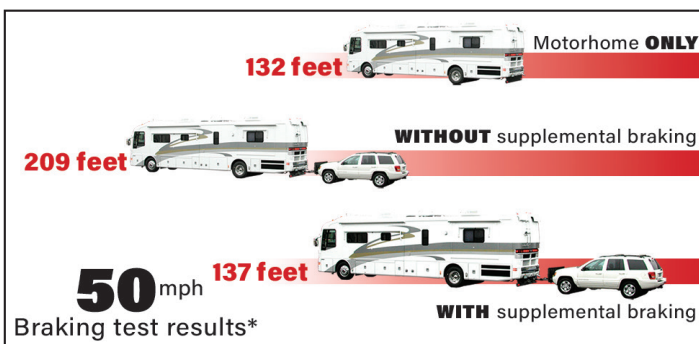

- Relieve stress on the tow bar and baseplates. A panic stop without supplemental brakes is a leading cause of tow bar system failure.
- Reduce the chance of a catastrophic brake failure at the motorhome as a result of sustained braking.

2 IT'S REQUIRED

According to the American Automobile Association, most states (plus many Canadian provinces) require brakes if the towed weight exceeds 3,000 lbs.

3 CHASSIS WARRANTY

Workhorse/Chevrolet can void your chassis warranty if you tow more than 1,000 lbs without supplemental brakes; Ford stipulates 1,500 lbs.

4 WEAR AND TEAR

Because they aren't braking for two vehicles, your motorhome brakes last longer.

5 IT JUST MAKES GOOD SENSE

Every other trailer on the road today (fifth wheels, travel trailers, boat trailers or semi-trailers) has its own braking system. When you're towing two or three extra tons, you should have a supplemental braking system to stop it!

Which System is Right for You?

DIRECT SYSTEM

BrakeMaster is recommended if your RV has air brakes. Because it connects directly to the motorhome's braking system, the initial installation is longer than a portable system. But once installed, it's a truly proportional, trouble-free and easy-to-use braking system.



BrakeMaster™
Proportional braking system

SET-IT-AND-FORGET-IT

InvisiBrake is recommended if you like convenience above all else. InvisiBrake is not a portable system, but the major components can be removed and installed in a new towed vehicle.



InvisiBrake®
'Set-it-and-forget-it' braking system

PORTABLE SYSTEM

Even Brake is recommended if you change towed vehicles or motorhomes often. Its plug & play design makes it easy to move from vehicle to vehicle. Even Brake is a sophisticated system with proportional braking.



Even Brake®
Portable proportional braking system

All three braking systems

- Greatly decrease your stopping distance, helping you avoid the danger and hassle of an accident.
- Include an emergency break away system, to stop your towed vehicle should it separate from your motorhome.
- Bring your towed vehicle into compliance with U.S. and Canadian requirements.
- Work with virtually any motorhome.
- Designed and manufactured in Vancouver, WA, USA

Weight Limits for Towing Without Supplemental Brakes

IT'S REQUIRED!

The states in red require supplemental brakes if the towed weight exceeds 3,000 lbs. The color key for the other states, as well as state-by-state weight limits, is listed below.

FEDERAL REGULATIONS

Title 49 (49CFR571) of the Federal Motor Vehicle Safety Standards defines a 'trailer' as: "Trailer means a motor vehicle with or without motive power, designed for carrying persons or property and for being drawn by another motor vehicle."

Specific Weight Limits United States

If the towed weight exceeds the following, a supplemental braking device is required.

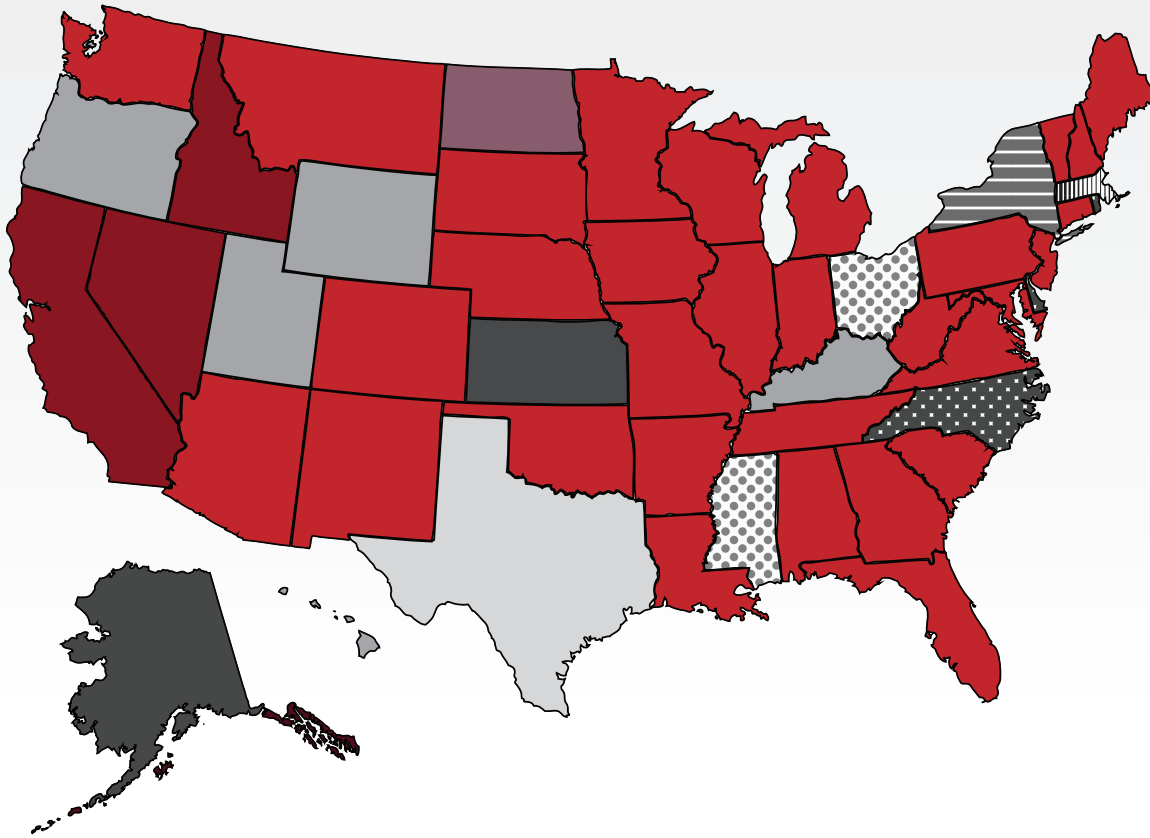
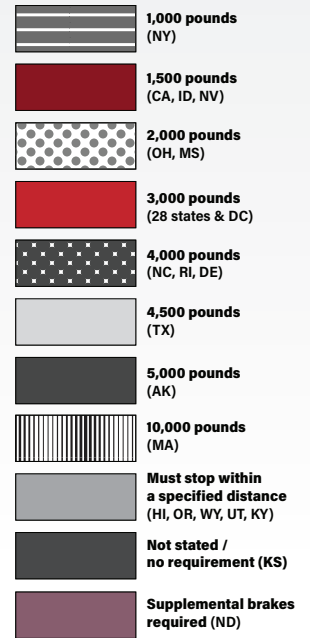

BRAKING SYSTEMS

United States

WEIGHT LIMIT (lbs)	WEIGHT LIMIT (lbs)	WEIGHT LIMIT (lbs)
Alabama.....3,000	Kentucky.....'A'	North Dakota.....'C'
Alaska.....5,000	Louisiana.....3,000	Ohio.....2,000
Arizona.....3,000	Maine.....3,000	Oklahoma.....3,000
Arkansas.....3,000	Maryland.....3,000	Oregon.....'A'
California.....1,500	Massachusetts.....10,000	Pennsylvania.....'C'
Colorado.....3,000	Michigan.....3,000	Rhode Island.....4,000
Connecticut.....3,000	Minnesota.....3,000	South Carolina.....3,000
Delaware.....4,000	Mississippi.....2,000	South Dakota.....3,000
District of Columbia.....3,000	Missouri.....3,000	Tennessee.....3,000
Florida.....3,000	Montana.....3,000	Texas.....4,500
Georgia.....3,000	Nebraska.....3,000	Utah.....'A'
Hawaii.....3,000	Nevada.....1,500	Vermont.....3,000
Idaho.....1,500	New Hampshire.....3,000	Virginia.....3,000
Illinois.....3,000	New Jersey.....3,000	Washington.....3,000
Indiana.....3,000	New Mexico.....3,000	West Virginia.....3,000
Iowa.....3,000	New York.....1,000	Wisconsin.....3,000
Kansas.....'B'	North Carolina.....4,000	Wyoming.....'A'

Canada

WEIGHT LIMIT (lbs)
Alberta.....2,000
British Columbia.....4,400
Manitoba.....2,000
New Brunswick.....3,000
Newfoundland.....'C'
Northwest Territories.....3,000
Nova Scotia.....4,000
Nunavut.....'B'
Ontario.....3,000
Prince Edward Island.....3,300
Quebec.....2,860
Saskatchewan.....3,000
Yukon Territory.....2,000

KEY

- 'A' Must stop within a specified distance
- 'B' Not stated / no requirement
- 'C' Supplemental brakes always required

Important! Every reasonable effort was made to verify the accuracy of this information; however, ROADMASTER, Inc. does not warrant its accuracy and disclaims all liability for any claims or damages which may result from errors or omissions.

INVISI BRAKE®



A revolutionary innovation in supplemental braking — NOTHING.

Zip. Zero. Zilch. Nothing. Nada. Nil. That's what you have to do to connect and disconnect InvisiBrake. There's nothing to take in or out of your towed vehicle and there's nothing to push, pull, set, adjust, activate or deactivate. What could be easier than nothing at all?

'Set-It-and-Forget-It' Braking
Simple. Reliable. Made to last.

BRAKING SYSTEMS

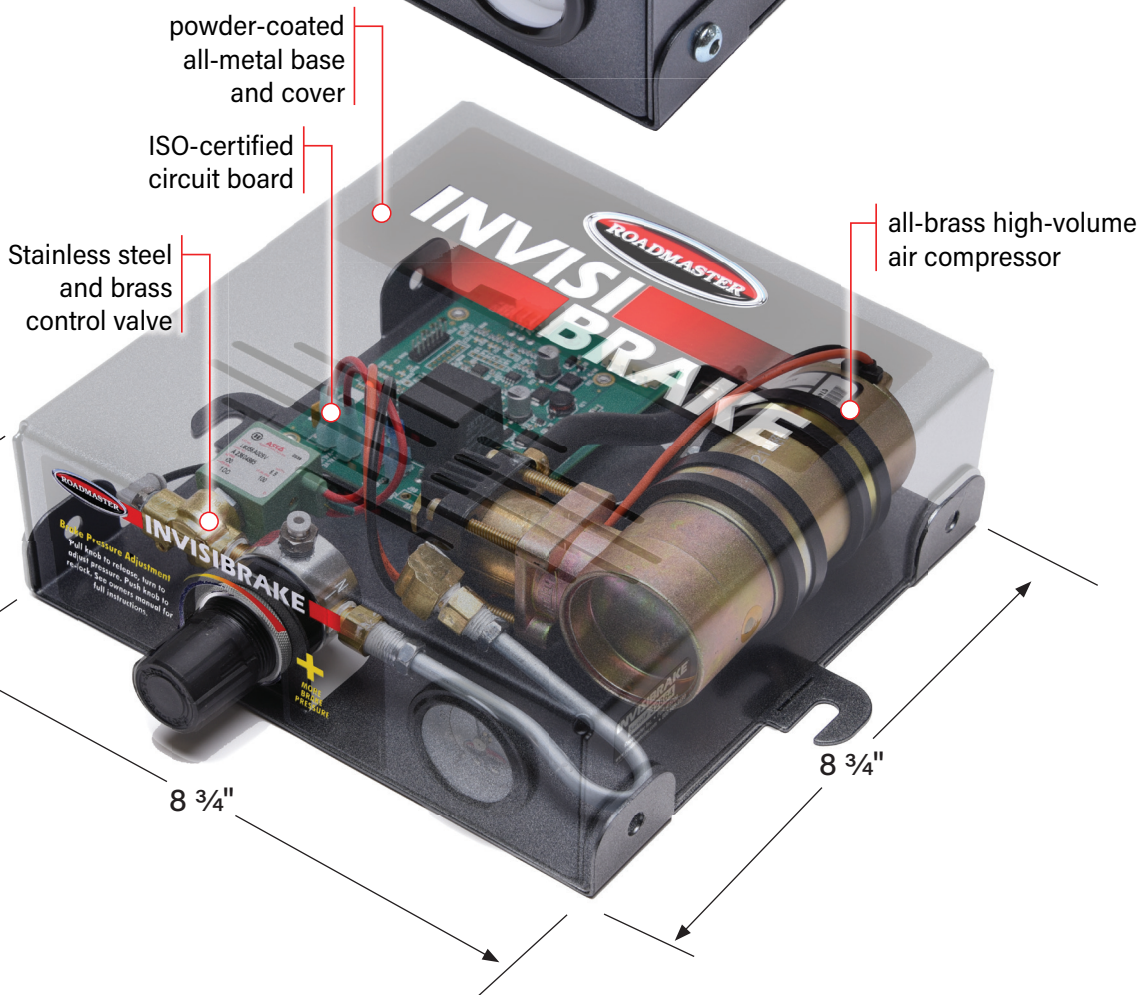

powder-coated
all-metal base
and cover

ISO-certified
circuit board

Stainless steel
and brass
control valve

all-brass high-volume
air compressor

2 3/4"

8 3/4"

8 3/4"



A. INVISIBRAKE - 8700

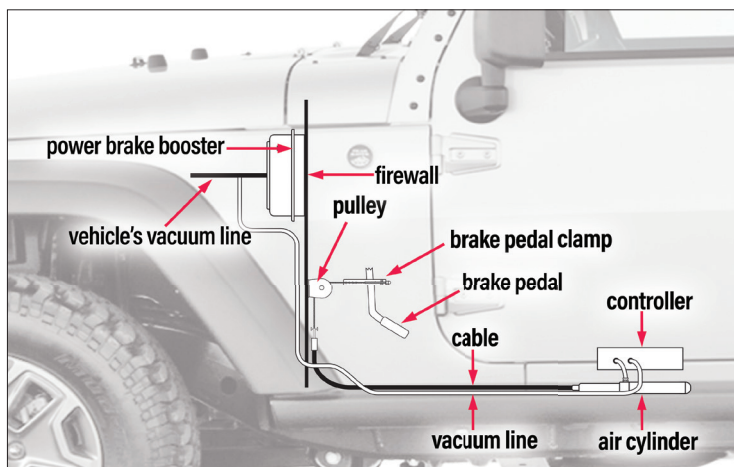

How does InvisiBrake work?

1. The controller receives a braking signal from the motorhome.
2. The vacuum created by the controller activates the power brakes.
3. The air cylinder pulls a cable that applies the brakes.



INCLUDES EXCLUSIVE TWO-STAGE MOTORHOME MONITOR

INCLUDES EMERGENCY BREAKAWAY SYSTEM

TRICKLE CHARGES THE TOWED VEHICLE'S BATTERY

INVISIBRAKE®
'Set-it-and-forget-it' braking

WHAT IS INVISIBRAKE?

InvisiBrake is a fully-automatic supplemental braking system that uses the electrical connections already in place on your towed vehicle (the towed vehicle's electrical harness) to brake when you brake the motorhome — the same electrical signal that activates the towed vehicle's brake lights also activates InvisiBrake.

- **OUT OF SIGHT**
InvisiBrake is so small (8¾" x 8¾" x 2¾") it can usually be mounted under the driver's seat, under the rear seat, behind interior panels or in the trunk.
- **SET-IT-AND-FORGET-IT BRAKING**
Once it's installed, InvisiBrake just works. Nothing for you to remember — not even an 'on' switch — just plug in the umbilical cord like you always do and you're ready to go!
- **CHARGES YOUR BATTERY WHILE TOWING**
InvisiBrake trickle-charges your battery during towing — InvisiBrake will never cause a dead battery.
- **TWO-STAGE MOTORHOME MONITOR**
Includes an LED monitor for a visual reference of braking activity; an audible alert at the motorhome will warn you if the brakes have been on for too long.
- **ACTIVATES ONLY WHEN THE MOTORHOME'S BRAKE LIGHTS ILLUMINATE — NO FALSE BRAKING!**
- **ENERGIZES YOUR POWER BRAKES** — InvisiBrake energizes power brakes instead of working on a 'dead' pedal.
- **WORKS IN NEARLY ANY TOWED VEHICLE**
with vacuum-powered brakes including hybrids and those with full-time ('active') power braking systems.
- **INCLUDES EMERGENCY BREAK AWAY SYSTEM**
- **EASILY ADJUSTS TO INDIVIDUAL PREFERENCES**
Braking pressure is adjustable from 5 to 100 psi.
- **MEETS U.S. AND CANADIAN BRAKING REQUIREMENTS**

A. INVISIBRAKE® SUPPLEMENTAL BRAKING SYSTEM

The best system available — Crafted in the USA.

Invisibrake — Complete Kit.....**8700**

EVEN BRAKE®
Portable Proportional Braking
 Even Brake ...Even Safer.

Even Brake is the ultimate portable, proportional towed vehicle braking system. It automatically increases or decreases braking pressure in direct proportion to the motorhome. In other words, it brakes evenly — at the same time, and at the same intensity, as you brake the motorhome.



Exclusive Features

- **FULL-TIME PROPORTIONAL BRAKING** — proportional braking is even braking — your towed vehicle's brakes respond to your motorhome's brakes, at the same time and intensity.
- **CONSTANT SELF-DIAGNOSTIC TESTING** — Even Brake monitors its own performance constantly, and any change in system status is transmitted to the motorhome monitor. Even Brake is the only supplemental braking system that checks itself, so you don't have to — a glance at the monitor assures you that Even Brake is fully operational.
- **'POWER SAVE' LOW BATTERY PROTECTION** — Even Brake warns you of a low battery in the towed vehicle with LED and LCD alerts at the motorhome monitor, giving you time to recharge the battery. If the battery voltage drops too low, Even Brake goes into sleep mode, while retaining emergency braking power.
- **'TERRAIN-SENSING LOGIC'** — Even Brake adjusts to uphill or downhill grades and to rough terrain by automatically leveling itself. Because it's always level, Even Brake always brakes with maximum efficiency.
- **NO FALSE BRAKING!** — Activates only when the motorhome's brake lights illuminate.

Additional Features

- **AUTOMATIC BRAKE PROTECTION** — the monitor alerts you after an extended period of continuous braking, then Even Brake releases braking pressure, avoiding excessive wear on the towed vehicle's brakes.
- **EASILY ADJUSTS TO INDIVIDUAL BRAKING PREFERENCES** — adjust braking force and sensitivity at the touch of a button.

A. EVEN BRAKE® SUPPLEMENTAL BRAKING SYSTEM
 Crafted in the USA.
EVEN BRAKE — Complete Kit **9400**



A. EVEN BRAKE - 9400



Even Brake's monitor gives you complete, continuous braking information — at a glance.
 Even Brake stays in constant communication with the motorhome, and with you. It reports any braking activity or a change in system status to a wireless monitor in the motorhome.

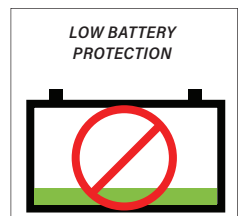
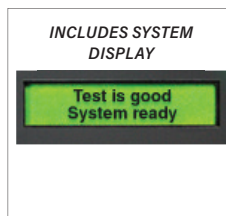



A. BRAKEMASTER - 9160

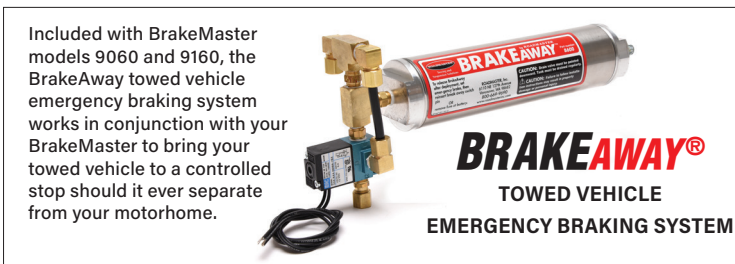

D. BRAKEAWAY - 8600

BRAKEMASTER®
Direct proportional braking

BrakeMaster is ROADMASTER's 'direct' proportional braking system. It connects directly to the motorhome's air or hydraulic braking system for rock-solid, reliable braking — brake line pressure in the motorhome controls the brakes in the towed vehicle. Because it connects directly to what powers your motorhome's brakes, BrakeMaster is a truly proportional, truly synchronized braking system — however you brake the motorhome, BrakeMaster automatically applies the same pressure. Every time.



Connects and disconnects from the towed vehicle in under a minute, without tools, adjustments or settings. Weighs just 3¾ lbs and measures 17 inches in length — stores almost anywhere.

BrakeMaster...

- ...has a robust, pneumatic design.
- ...works in virtually any motorhome.
- ...works in virtually any towed vehicle with power brakes.
- ...easily disconnects from the brake pedal — from towed car to road car in seconds!
- ...includes a break away emergency braking system.
- ...meets U.S. and Canadian braking requirements.

There's a BrakeMaster for all types of motorhome brakes...

- A. **BRAKEMASTER WITH BRAKEAWAY**
for motorhomes with air or air over hydraulic brakes..... **9160**
- B. **BRAKEMASTER WITHOUT BRAKEAWAY** (not shown)
for motorhomes with air or air over hydraulic brakes..... **9100**
- C. **BRAKEMASTER WITH BRAKEAWAY** (not shown)
for motorhomes with hydraulic brakes..... **9060**
- D. **BRAKEAWAY EMERGENCY BRAKING SYSTEM** (not shown)
(included with 9060 and 9160)..... **8600**

NOTE:
Brakemaster requires a vehicle-specific seat adapter.
(See Brakemaster accessories - page 16)

SECOND VEHICLE KITS

If you already have a supplemental braking system and want to put it in a new towed vehicle, these kits allow you that freedom, without the expense of purchasing a complete system. Just transfer the expensive components of your existing system. The labor to remove all of the wiring harnesses, air hoses and fittings can be expensive. The second vehicle kit contains these components and simplifies the installation of your core components in your new vehicle.

A. FOR BRAKEMASTER

If you switch BrakeMaster between two vehicles, install the 98100 or the 98160 in the second vehicle. The 98100 and 98160 are identical except the 98160 includes a BrakeAway kit.....**98100 / 98160**

B. FOR EVEN BRAKE (not shown)

If you switch Even Brake between two vehicles, install this break away system, ICX transmitter and Brake-Lite Relay in the second vehicle. 98400 is for Even Brakes with serial numbers up to 27,496; 98450 is for Even Brakes with serial numbers above 27,496).....**98400 / 98450**

C. FOR INVISIBRAKE RE-INSTALLATION

This kit facilitates the re-installation of an Invisibrake to a new vehicle.....**98700**



A. SECOND VEHICLE KIT - BRAKEMASTER - 98160



C. SECOND VEHICLE KIT - INVISIBRAKE RE-INSTALLATION - 98700

SECOND MOTORHOME KITS

These kits provide replacement components for your current supplemental braking system in case you change motorhomes.

D. FOR BRAKEMASTER

If you change motorhomes, install these components in the motorhome. The 98200 is for motorhomes with air or air over hydraulic brakes; the 98300 is for motorhomes with hydraulic brakes.....**98200 / 98300**

E. FOR EVEN BRAKE (not shown)

This is an Even Brake Monitor for your 2nd motorhome.**9410**

F. FOR INVISIBRAKE

These are the Invisibrake monitor/alarm components that need to be installed in a new or 2nd motorhome.....**98850**



D. SECOND MOTORHOME KIT - BRAKEMASTER - 98200



F. SECOND MOTORHOME KIT - INVISIBRAKE - 98850

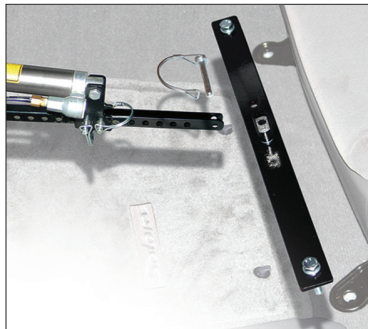

A. SEAT ADAPTERS - VARIES



B. BRAKE PRESSURE REDUCER
- 900002



C. AIR CYLINDER STORAGE BAG
- 104



D. 88-INCH PATCH CORD
- 921004-88



E. METRIC TO STANDARD TEE - 7921



G. METRIC TO STANDARD TEE - 7923



H. SPARTAN TOW BRAKE ADAPTER
- 921001-20



I. 12v EXTENSION CORD - 6'
- 9331



J. 12V OUTLET KIT - 4'- 9332



K. INVISIBRAKE PULLEY
MOUNTING BRACKET - 8700-PBC

BRAKEMASTER ACCESSORIES

A. SEAT ADAPTERS

Provide a vehicle-specific mounting location for the BrakeMaster air cylinder. They're designed to contour to the floor and use existing mounting points on the seat tracks, which streamlines installation and allows them to remain out of sight when BrakeMaster is not in use. Available for most vehicles. Find your fit at roadmasterinc.com/fitmaster..... **VARIES**

B. BRAKE PRESSURE REDUCER

This product allows you to install BrakeMaster in a hybrid, a Hummer H3 or in any vehicle with a full-time ('active') power braking system – reduced air pressure eliminates over-braking issues. Works in any supplemental braking system that utilizes a "dead" brake pedal and which uses pressurized air to brake the towed vehicle.....**900002**

C. AIR CYLINDER STORAGE BAG

Protects the Brakemaster air cylinder from dirt..... **104**

D. 88-INCH BRAKEMASTER PATCH CORD

If you're using a drop hitch, or any accessory which extends the length of the towing system, use this patch cord. It's 12 inches longer than the standard patch cord (part number 921004).
.....**921004-88**

METRIC-TO-STANDARD BRAKE LINE TEES

Use these tees to install the BrakeMaster 9060 proportioning valve in motorhomes with metric brake lines.

- E. For 12 millimeter brake lines (12mm x 1.25 thread) **7921**
- F. For 12 millimeter brake lines. (12mm x 1.50 thread) (not shown).....**7924**
- G. For 10 millimeter brake lines. (10mm x 1.0 thread)**7923**

H. SPARTAN TOW BRAKE ADAPTER

Connects a standard 1/4" air brake line to a Spartan tow brake quick coupler.....**921004-20**

INVISIBRAKE + EVEN BRAKE ACCESSORIES

- I. 12-VOLT EXTENSION CORD – six-foot cord.....**9331**
- J. 12-VOLT OUTLET KIT – four-foot cord..... **9332**
- K. INVISIBRAKE PULLEY MOUNTING BRACKET
Use this optional bracket to create a surface for mounting the pulley..... **8700-PBC**

BRAKING SYSTEMS ACCESSORIES

BRAKE LIGHT SWITCH

Why do you need a brake light switch? Brake light switches are necessary only if you're installing a supplemental braking system monitor, and the vehicle's OEM brake light switch doesn't work when the vehicle is in 'tow' mode.

Both the universal switch and our vehicle-specific switches are only activated when the brake pedal is depressed. No other manufacturer provides brake light switches with this level of specificity. If you know when the towed vehicle's brake pedal is depressed and released, then you know if the supplemental braking system is positioned properly and working as it should.

A. UNIVERSAL BRAKE LIGHT SWITCH

This switch sends a beam of infrared light to detect brake pedal movement. When the pedal moves down, it sends a signal to the monitor that the brakes have been applied.

- Works on any vehicle with a brake pedal.
- Works with any supplemental braking system that moves the brake pedal.751000

B. VEHICLE-SPECIFIC BRAKE LIGHT SWITCHES

Available for most popular towed vehicles

FIND YOUR FIT

Scan the QR code or visit fitmaster.roadmasterinc.com and enter your vehicle's year, make and model.



(not shown)..... VARIES

C. BRAKE LIGHT RELAY

Why do I need a Brake-Lite Relay?

It stops the brake lights from functioning until the vehicle is started. This prevents the towed vehicle's brake signal from overriding the motorhome's turn signal.

You only need a Brake-Lite Relay if you're installing a supplemental towed vehicle braking system that pushes or pulls the brake pedal. (comes standard with Even Brake®)

Exceptions -

- With the engine off, step on your brakes. If the brake lights do not illuminate, you do not need a Brake-Lite Relay.
- If you're using magnetic tow lights or a bulb and socket wiring kit, you do not need a Brake-Lite Relay.
- If the motorhome and towed vehicle are wired for separate brake and turn signals, you do not need a Brake-Lite Relay.

.....88400

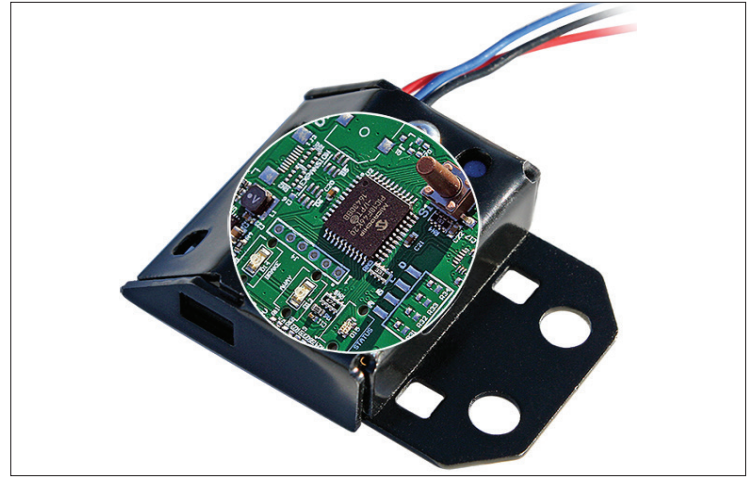

A. UNIVERSAL BRAKE LIGHT SWITCH - 751000



C. VEHICLE-SPECIFIC BRAKE LIGHT SWITCH - VARIES



C. BRAKE LIGHT RELAY - 88400

BRAKING SYSTEMS ACCESSORIES



A. WIRELESS UNIVERSAL BRAKING SYSTEM MONITOR - 9530

A. WIRELESS UNIVERSAL SUPPLEMENTAL BRAKING SYSTEM MONITOR

- The best upgrade or replacement monitor available –
- Truly universal – works with all braking systems that depress the brake pedal.
 - Exceptional range and reliability – line-of-sight transmission confirmed to 1,000 feet; proprietary send/repeat circuitry confirms each signal at 100 percent reception.
 - Protects the towed vehicle's brakes – reports any braking activity to the motorhome monitor; includes a low-battery alert, extended braking and break-away alarms, and five other audio and/or visual alarms and system status notifications.
 - 30-minute installation, all at the towed vehicle; simply plug the motorhome monitor into any 12-volt outlet.
 - Automatic operation – activates only when the vehicles are connected for towing.

Specifications

Frequency:	923 MHz
Voltage:	12V
Sleep Current:	30mA

UNIVERSAL BRAKING SYSTEM MONITOR..... 9530



B. BREAK AWAY SWITCH AND PIN - 650898

C. BREAK AWAY PIN AND RING - 200200-20

B. BREAK AWAY SWITCH AND PIN

Our replacement break away switch has a sealed, corrosion-resistant ABS housing and metal contact points. **650898**

C. BREAK AWAY PIN AND RING..... 200200-20



D. BREAK AWAY CABLE - 8603

D. BREAK AWAY CABLE

A self-supporting, coiled design provides lift off the road surface while still allowing plenty of slack for cornering. Extends to eight feet and conveniently retracts for storage. Ideal for virtually any break away system (includes snap hooks). **8603**

TOWING ACCESSORIES

THE EXTRAS YOU NEED FOR TOWING A VEHICLE

COMBO KITS

TOW BARS, YOU'VE MET YOUR MATCH.

Combo Kits contain the accessories you need, matched to your ROADMASTER tow bar. Each Combo Kit contains:

- A wiring kit with four 'Hy-Power' diodes
- A 7 to 6 way power cord with plugs to conduct lighting signals. Includes electrical socket and socket mounting bracket for the towed vehicle. (Note: The Sterling All-Terrain and Nighthawk come with power cords, so this kit does not include them)
- A pair of safety cables, rated at 6,000-, 8,000- or 10,000-lb. capacity (Note: The Sterling All-Terrain and Nighthawk come with safety cables, so this kit does not include them)
- Two or three case-hardened steel padlocks (keyed alike)
- A marine-grade vinyl cover to protect your tow bar
- A marine-grade vinyl storage bag — for all your accessories

- A. NIGHTHAWK AND STERLING ALL-TERRAIN COMBO KIT**
Includes the items listed above, a receiver hitch lock and silicone spray tow bar lubricant. Does not include safety cables or power cord.**9284-2**
- B. FALCON 2 AND FALCON ALL-TERRAIN COMBO KIT**
Includes the items listed above, 6,000 lb. rated straight safety cables and power cord.**9243-1**
- C. BLACKHAWK 2 ALL-TERRAIN COMBO KIT (not shown)**
Includes the items listed above, 10,000 lb. rated straight safety cables and power cord.**9243-3**
- D. STOWMASTER COMBO KIT (not shown)**
Includes the items listed above, 6,000 lb. rated coiled safety cables and power cord.**9252**



A. COMBO KIT - 9284-2



B. COMBO KIT - 9243-1



E. FOR 7- TO 6-WIRE TOWING COMBINATIONS - 15267



F. FOR 7- TO 4-WIRE TOWING COMBINATIONS - 15247

'ALL-IN-ONE' TOWED VEHICLE WIRING KITS

Complete wiring kits for the two most popular combinations.

- A 7 to 6 (or 7 to 4) coiled power cord
 - Four Hy-Power® diodes
 - A 27-foot length of 4-wire electrical cord
 - Three feet of split wire loom
 - Electrical socket & mounting bracket
 - A ring terminal & wire connectors
 - Cable ties & Flexo-Coil power cord
 - Step-by-step instructions
- E. FOR 7- TO 6-WIRE TOWING COMBINATIONS15267**
- F. FOR 7- TO 4-WIRE TOWING COMBINATIONS15247**



A. HYBRID CABLES - 674



C. STANDARD SAFETY CABLES - COILED - 643



F. STANDARD SAFETY CABLES - STRAIGHT - 645



K. SAFETY CABLE EXTENSIONS - 910648-8

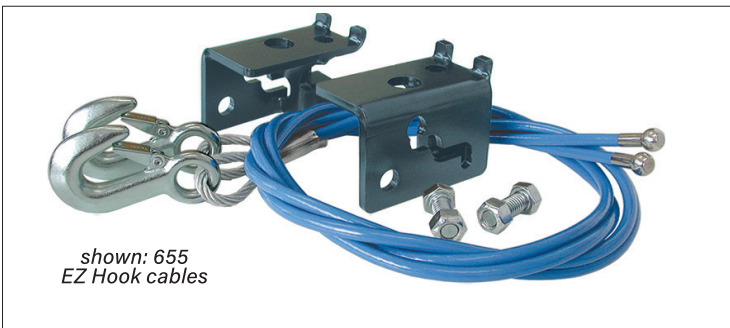

shown: 655
EZ Hook cables

K. EZ HOOK SAFETY CABLES- 655

SAFETY CABLES

These aircraft-type, galvanized steel cables are continuously tested to ROADMASTER's exacting standards.

- Vinyl coating prevents the safety cables from scratching or chipping the tow bar.
- Every snap hook is made of heavy-duty, drop-forged steel with spring-loaded latches for maximum strength and security.

HYBRID SAFETY CABLES

The straight portion of these cables can be routed through the channels built into the tow bar for a clean appearance and protection from road rash. The coiled portion of these cables expand to accommodate drop hitches or extensions. Cables expand to 80", then contract for storage. Each kit contains two cables, four snap hooks and two quick links.

- A. 80" 8,000-LB. CAPACITY PER PAIR CABLES 674
- B. 1 REPLACEMENT SAFETY CABLE FOR 674 (not shown).....910676

COILED AND STRAIGHT SAFETY CABLES

Each kit contains two cables, snap hooks and two quick links. Rated at 6,000-, 8,000- or 10,000-lb. capacity per pair, depending on the model you choose. All safety cables are sold in pairs.

- C. 68" 6,000-LB. SINGLE HOOK COILED643
- D. 68" 6,000-LB. DOUBLE HOOK COILED (not shown)643-2
- E. 76" 8,000-LB. SINGLE HOOK STRAIGHT (not shown)..... 645-76
- F. 64" 8,000-LB. SINGLE HOOK STRAIGHT645
- G. 64" 8,000-LB. DOUBLE HOOK STRAIGHT (not shown)646
- H. 64" 10,000-LB. SINGLE HOOK STRAIGHT (not shown).....649
- I. 64" 10,000-LB. DOUBLE HOOK STRAIGHT (not shown)..... 648
- J. 80" 10,000-LB. DOUBLE HOOK COILED (not shown)653

K. SAFETY CABLE EXTENSIONS

Extensions (or longer safety cables, see above) may be necessary for use with accessories which extend the length of the towing system. Each pair includes a pair of quick links - 8,000-pound capacity per pair

- | | |
|--------------------|--------------------|
| 8"910648-8 | 16"910648-16 |
| 10"910648-10 | 17"910648-17 |
| 12"910648-12 | 18"910648-18 |
| 13"910648-13 | 19"910648-19 |
| 14"910648-14 | 20"910648-20 |
| 15"910648-15 | 22"910648-22 |

EZ HOOK™ SAFETY CABLES

For legacy crossbar style baseplates only - 8,000 lb capacity per pair

- L. 68" EZ HOOK (1 pair - with anchor plates)655
- M. 68" EZ HOOK (1 pair - w/o anchor plates) (not shown)..655-68
- N. 68" EZ HOOK (1 cable only) (not shown).....910650-68
- O. 64" EZ HOOK (1 pair - w/o anchor plates) (not shown)...655-64
- P. 64" EZ HOOK (1 cable only) (not shown).....910650
- Q. 76" EZ HOOK (1 pair - w/o anchor plates) (not shown)....655-76
- R. 76" EZ HOOK (1 cable only) (not shown)..... 910650-76
- S. EZ HOOK ANCHOR PLATES (1 pair) (not shown)910653

TOWED VEHICLE WIRING KITS

A towed vehicle's turn signals, running lights and brake lights must mimic the motorhome's as required by law. There are a few ways to accomplish that:

- 1) diodes;
- 2) bulbs and sockets; or
- 3) magnetic / LED tow lights

Whichever one you choose, we have a kit with the necessary components. Not all kits will work with all vehicles.

FIND YOUR VEHICLE-SPECIFIC KIT

Scan the QR code or visit fitmaster.roadmasterinc.com and enter your vehicle's year, make and model.



UNIVERSAL WIRING KITS

These kits use a system of diodes to connect your towed vehicle's turn signals, running lights and brake signals to your motorhome's. Diodes prevent electrical feedback and protect both vehicles' electrical systems.

The Universal wiring kit includes:

- Four Hy-Power® diodes
- A 27-foot length of 4-wire electrical cord with 4-wire flat connectors
- Three feet of split wire loom
- A six-foot power cord with 4-wire flat connectors (connects electricity between the two vehicles)
- A ring terminal & wire connectors
- Cable ties & step-by-step instructions

- | | |
|--|-------|
| A. UNIVERSAL WIRING KIT | 154 |
| B. ECONOMY WIRING KIT | |
| Similar to the 154 Universal wiring kit but without the 4-wire plugs or six-foot power cord..... | 152RP |

SMART DIODE KITS FOR VARIABLE VOLTAGE VEHICLES

Diodes are frequently used to prevent the backflow of current to the electrical system of the towed vehicle or motorhome; however, many newer vehicles now use a multiplex wiring system, whereby multiple electrical signals may be sent down a single wire (brake and taillights, for example). This is called variable voltage.

If an ordinary diode is used in these applications, then the bulb will illuminate as though the vehicle is braking. That is, you can't tell the difference between the brake lights and running lights.

Smart Diodes correctly modulate the voltage to activate only the intended circuit. The result is vehicle lighting that looks and functions as intended. Whereas four regular diodes are required per vehicle, Smart Diodes only require two.

- | | |
|---|--------|
| C. TOWED CAR WIRING KIT WITH SMART DIODES FOR VEHICLES WITH LED BULBS | 153789 |
| D. TOWED CAR WIRING KIT WITH SMART DIODES FOR VEHICLES WITH INCANDESCENT BULBS | 153782 |
| E. TOWED CAR WIRING KIT WITH SMART DIODES FOR JEEPS WITH PARKSENSE (not shown)
(see roadmasterinc.com/pdf/85-6213.pdf for more info)
..... | 152789 |



A. UNIVERSAL WIRING KIT - 154

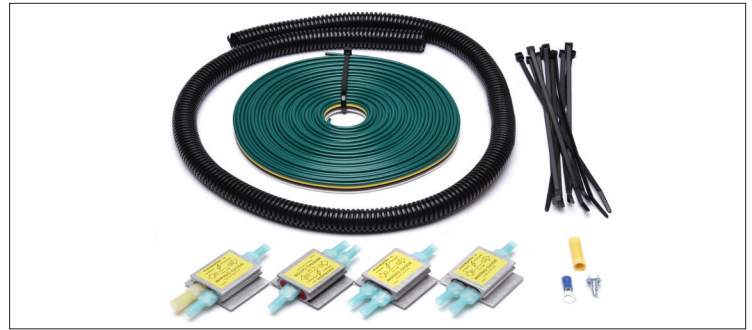

B. ECONOMY WIRING KIT - 152RP



C. TOWED CAR WIRING KIT (LED) - 153789



D. TOWED CAR WIRING KIT (INCANDESCENT) - 153782



A. BULB AND SOCKET KIT W/INCANDESCENT BULBS - 155



B. BULB & SOCKET KIT W/LED BULBS - 152-LED



C. LED TOWED CAR LIGHTING KIT - 157



D. MAGNETIC TOW LIGHTS - 2120

ELECTRICAL

INCANDESCENT BULB AND SOCKET KITS

A bulb and socket kit bypasses the towed vehicle's electrical system. This eliminates the concern of interacting with any vehicle electronics. However, it does require drilling a hole into the backside of the tail light.

This complete kit contains a 27-foot wiring harness, butt connectors, two incandescent bulbs, two sockets, zip ties, ring terminals, split loom and installation instructions.

Note: The towed vehicle's taillights must have room for an extra socket and bulb inside the lens housing. To see if a bulb and socket will fit in your vehicle, visit fitmaster.roadmasterinc.com.

A. BULB AND SOCKET KIT W/INCANDESCENT BULBS155

LED BULB AND SOCKET KIT

LEDs have significant safety and appearance advantages over incandescent bulbs — they're brighter, they activate faster and they last longer. They also draw significantly less amperage and are therefore less of a strain on the electrical system.

This complete kit contains a 27-foot wiring harness, two LED bulbs, two sockets, zip ties, ring terminals, butt connectors, split loom and installation instructions.

B. BULB & SOCKET KIT W/LED BULBS 152-LED

C. LED TOWED CAR LIGHTING KIT

Designed as a wiring solution for vehicles where traditional wiring diodes will not work. Kit includes a separate wiring harness that routes from the front to the rear of the vehicle. Adhesive backing allows the installer to place the lights at a convenient location.

- Color-coded wiring for easy plug-and-play installation
 - LED strip protected from moisture & dust with an IP68 rating.
 - Displays turn signals, running, and braking lights.
- 157

D. MAGNETIC TOW LIGHTS

Magnetic tow lights are a quick and easy way to connect your towed vehicle's electrical system to your motorhome's. With 4-wire flat plugs and harness.....2120

ELECTRICAL

HY-POWER® DIODES

Diodes are used to connect the towed vehicle's brake light, running light and turn signal wiring to the motorhome.

Diodes permit electrical current to flow in only one direction preventing electrical feedback and damage to both vehicles' electronics.

Hy-Power diodes have a heavy-duty aluminum heat sink, and each diode is protected against the elements — all components are housed inside an epoxy-sealed aluminum case. Heavy-duty 85 amp rating. Four diodes required for most vehicles.

- A. HY-POWER DIODE (qty=1) **790**
- B. HY-POWER DIODE (qty=2) **792**
- C. HY-POWER DIODE (qty=3) **793**
- D. HY-POWER DIODE (qty=4) **794**
- E. HY-POWER DIODE (qty=25) **790-25**

SMART DIODES

Smart Diodes correctly modulate the voltage to activate only the intended circuit. The result is vehicle lighting that looks and functions as intended. Whereas four regular diodes are required per vehicle, Smart Diodes only require two. Although designed for multiplexing vehicles, they can be used in place of regular diodes.

- F. 2-PACK FOR VEHICLES WITH INCANDESCENT BULBS **782**
- G. 2-PACK FOR VEHICLES WITH LED BULBS **789**
- H. 12-PACK FOR VEHICLES WITH INCANDESCENT BULBS **780-12**
- I. 12-PACK FOR VEHICLES WITH LED BULBS **787-12**

J. PARK LIGHT DIODE

Use a Park Light diode to stop any interaction between the two park light systems, preventing electrical feedback and electrical damage. Not necessary if using Hy-Power or Smart Diodes. **690**

K. BRITE-LITE® 3-TO-2 CONVERTER

If you have this — the motorhome has separate brake and turn signal lights; the towed vehicle has combined brake and turn signal lights.

You need this — the Brite-Lite converter connects a vehicle with a separate brake and turn signal system to a vehicle with a combined brake and turn system, while delivering more current to the towed vehicle's brake and turn signal lights for brighter illumination.

BRITE-LITE 3-TO-2 WIRING CONVERTER..... **732**

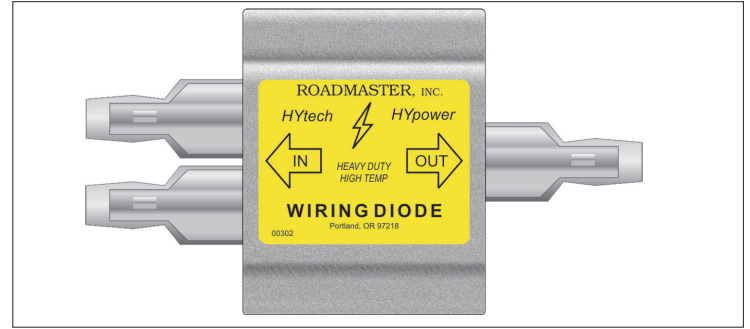

A. HY-POWER® DIODE - 790



G. SMART DIODES - LED - 789

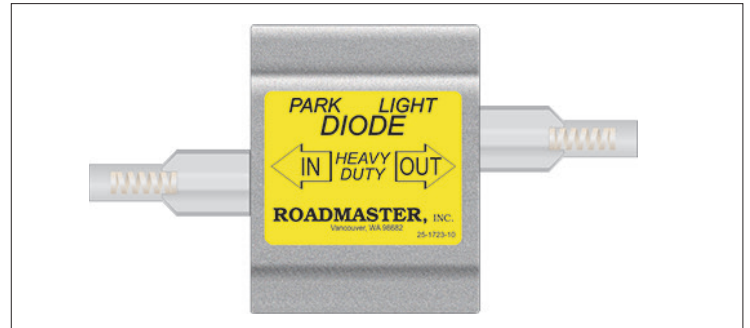

J. PARK LIGHT DIODE - 690



K. BRITE-LITE® 3-TO-2 CONVERTER - 732



A. 6-WIRE FLEXO-COIL CORD KIT - 1676-7



D. 6-WIRE FLEXO-COIL CORD KIT - 1466



F. 7- TO 6-WIRE STRAIGHT CORD KIT - 98146-7



K. STRAIGHT BRACKET - 910030

L. 90° BRACKET - 910030-5

ELECTRICAL

HYBRID & FLEXO-COIL® POWER CORD KITS

Connects electricity between the towed vehicle and the motor-home for braking, turn signals, and tail lights.

ROADMASTER's power cords are the best — the wires are water-, oil- and chemical-resistant, and the plugs are injected with silicone to prevent corrosion. Flexo-Coil cords expand to more than eight feet and conveniently contract for storage.

- A. 7- TO 6-WIRE HYBRID CORD KIT1676-7
- B. 7- TO 6-WIRE FLEXO-COIL CORD KIT
with plugs, sockets and socket bracket (not shown)146-7
- C. 7- TO 4-WIRE FLEXO-COIL CORD KIT
with plugs, sockets and socket bracket (not shown)164-7
- D. 6-WIRE FLEXO-COIL CORD KIT
with plugs, sockets and socket bracket1466
- E. 4-WIRE FLEXO-COIL CORD KIT
with plugs, sockets and socket bracket (not shown)1644

STRAIGHT CORD POWER CORD KITS

For tow bars with cable channel guides (All-Terrain)

- F. 7- TO 6-WIRE STRAIGHT CORD KIT
w/plugs, socket and socket bracket98146-7
- G. 7-TO 4-WIRE STRAIGHT CORD KIT
w/plugs, socket and socket bracket (not shown)98164-7
- H. 6-WIRE STRAIGHT CORD KIT
w/plugs and sockets (not shown)..... 98146
- I. 4-WIRE STRAIGHT CORD KIT
w/plugs and sockets (not shown)..... 98164
- J. BULK POWER CORD COMPONENTS
4-wire socket 910030-1 4-wire plug only....910030-2
6-wire socket.....910030-7 6-wire plug only ...910030-8
7-wire socket..... 9338-70 7-wire plug only9338-77

HEAVY-DUTY SOCKET BRACKETS

Built from thick steel, these brackets hold the towed vehicle's electrical socket firmly in place, making it easy to plug and unplug the power cord. Both brackets fit most electrical sockets, and can be either welded or bolted in place.

- K. STRAIGHT BRACKET.....910030
- L. BRACKET WITH 90° BEND.....910030-5

ELECTRICAL

A. REMOTE BATTERY DISCONNECT

Never disconnect the battery cable to tow!

After you install ROADMASTER's battery disconnect, your vehicle can be towed and then driven without any further adjustment to the battery — ever!

- Works on virtually all 12-volt batteries
- Pre-assembled for easy installation
- Provides a positive current source for break away systems or other accessories.
- Activates with a remote switch usually located inside the towed vehicle's passenger compartment.

REMOTE BATTERY DISCONNECT766

Note: Not for use with diesel engine vehicles.

For the complete vehicle fit list, visit fitmaster.roadmasterinc.com.



A. REMOTE BATTERY DISCONNECT - 766

B. HEAVY DUTY MANUAL BATTERY DISCONNECT

The 767 Battery Disconnect can be used for all vehicles including ones that require higher cranking amps often found in diesels. The 767 battery disconnect is typically mounted under the hood with the included hardware. In some cases, a vehicle will have two batteries. If BOTH batteries are on an engine starting circuit, you will need one disconnect per battery. Features high quality construction and an easy-to-read indicator dial. Although intended for dinghy towing, it has other applications, such as a hidden kill switch to deter auto thieves.....767

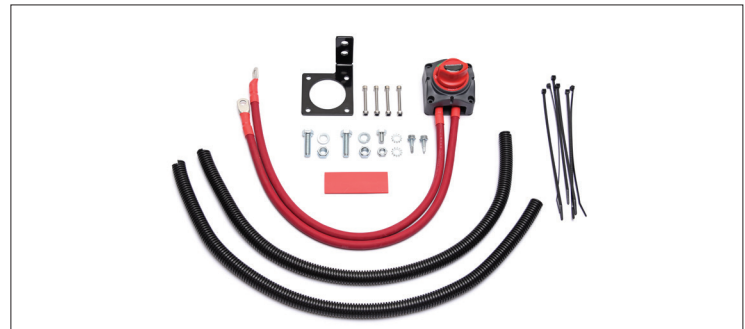

B. HEAVY DUTY MANUAL BATTERY DISCONNECT - 767

C. CHARGE LINE KITS

These simple, easy-to-install kits help maintain the vehicle's battery charge while in tow, supplying up to 15 amps of current. They also extend battery life by providing a constant maintenance charge during towing.

TOWED VEHICLE CHARGE LINE KIT156-25

MOTORHOME CHARGE LINE (not shown).....156-75

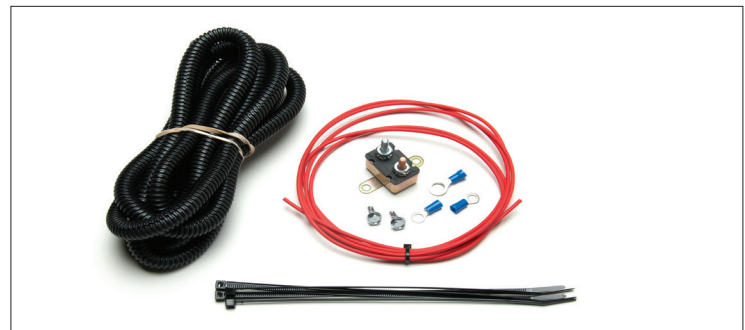

C. TOWED VEHICLE CHARGE LINE KIT - 156-25

D. FUSEMASTER

How about if you never had to spend another minute with your face on the floor mat, gazing up into a black void, hunting for a minuscule piece of plastic playing hide and seek? You don't have to. FuseMaster eliminates the necessity of having to remove a fuse for towing, then having to reinsert it for driving. After it's installed, you simply flip a switch to accomplish the same task.

..... **VARIES**

For the complete vehicle fit list, visit fitmaster.roadmasterinc.com.



D. DOUBLE-FUSE FUSEMASTER - 76514

FIND YOUR VEHICLE-SPECIFIC KIT

Scan the QR code or visit fitmaster.roadmasterinc.com and enter your vehicle's year, make and model.





A. MOTORHOME-MOUNTED TOW BAR COVER - 055-3



B. STOWMASTER TOW BAR COVER - 052-3



C. QUICK-DISCONNECT CROSSBAR COVER - 105

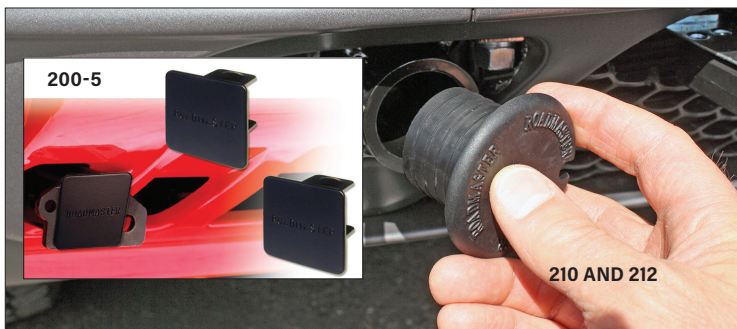

D. E. F. BASEPLATE PLUGS - 210 - 212 - 200-5



G. ROADWING - 4400

COVERS

MARINE-GRADE COVERS

Made of heavy-duty black vinyl, these covers are hand-crafted at the ROADMASTER plant for a custom fit.

Proudly displaying the ROADMASTER logo, each of these 'car wash safe' covers will help keep your tow bar, quick disconnects (Q.D.s), and Q.D. crossbar free of dirt and road grime when not in use, ensuring smooth and easy tow bar operation. The quick-disconnect crossbar cover is designed to cover the car-side Q.D.s and crossbar when the tow bar is disconnected.

- A. MOTORHOME-MOUNTED TOW BAR COVER 055-3
- B. STOWMASTER TOW BAR COVER 052-3
- C. QUICK-DISCONNECT CROSSBAR COVER..... 105

BASEPLATE PLUGS

These heavy-duty plugs help keep out dirt, gravel and grime when your baseplate arms are removed. Each plug is stamped with the ROADMASTER name and will give your towed vehicle that finished look.

- D. FOR 1½" INNER DIAMETER ROUND TUBES
1 pair, heavy-duty rubber 210
- E. FOR 1¼" INNER DIAMETER ROUND TUBES
1 pair, heavy-duty rubber 212
- F. FOR 1½" INNER DIAMETER SQUARE TUBES
1 pair, heavy-gauge steel 200-5

PROTECTION

ROADWING REMOVABLE MUD FLAP SYSTEM

RoadWing's 'anti-sail' design keeps the mud flaps down, where they can stay on the job — double-bolt attachment points hold the system in place and grooved interior channels deflect rocks, gravel and road debris down and away from your towed vehicle or trailer.

The RoadWing fits most 2" hitch receivers. It slides over your ball mount or tow bar stinger and is easily attached with set bolts, or just as easily detached. The 24" x 24" flaps can be trimmed to fit nearly any height of vehicle.

- G. ROADWING 77" - fits full size trucks 4400
- H. ONE REPLACEMENT MUD FLAP 200345-00

VEHICLE PROTECTION

TOW DEFENDER

A bumper-to-bumper blanket of protection!

The Tow Defender's all-weather, heavy-duty screen deflects rocks, gravel and road debris down and away, protecting your towed vehicle's finish, headlights and windshield against chips and dings. The vinyl-coated mesh lets air through, keeping it low and over the road. The Tow Defender offers 20 square feet of protection, and is held in place with shock-absorbing gas struts. Once you've reached your destination, roll up the Tow Defender and snap the elastic straps around each end for storage.

- Quick installation and release
- Lightweight and compact — weighs just 14½ lbs, and rolls up to four inches in diameter
- Powder-coated steel supports and heavy-duty gas struts for maximum cornering flexibility
- Reinforced seams and gussets for added longevity

- A. TOW DEFENDER** fits all ROADMASTER motorhome-mounted tow bars, Blue Ox tow bars, and Demco tow bars **4750**
- B. TOW DEFENDER** fits all ROADMASTER tow bars with quick-disconnects (does not fit 'direct-connect' style baseplates) **4700**



Gas struts automatically compress for cornering.

B. TOW DEFENDER - 4700 - 4750

GUARDIAN

Protects your towed vehicle from dings and rock chips.

The Guardian is crafted from rotationally-molded, high-impact polyethylene to absorb the impact of rocks, gravel and road debris — instead of ricocheting it back at the motorhome. The Guardian can be attached and removed in seconds, and fits all ROADMASTER tow bars equipped with quick-disconnects (Note: 'direct-connect' style baseplates will not accommodate the Guardian). If you tow more than one vehicle, the second vehicle kit has all the mounting hardware necessary to swap the Guardian from one vehicle to another. For ultimate protection, use the Guardian AND Tow Defender in tandem.

- C. GUARDIAN ROCK SHIELD** **4000**
- D. SECOND VEHICLE KIT** (not shown) **4000-1**
- E. GUARDIAN ADAPTER FOR TOW DOLLY** (not shown) **2000-8**



C. GUARDIAN - 4000

STOWAWAY

Guardian storage system

The Stowaway mounts over your tow bar's stinger or ball mount to convert the rear of your motorhome into a storage area for your Guardian rock shield. A center cut-out affords quick and easy access to the hitch and electrical socket. A simple hitch pin allows for easy removal of the Stowaway to gain rear compartment access or to check fluids on a rear diesel engine. With a set of optional quick-disconnects, the Stowaway will also store a StowMaster tow bar or a ROADMASTER quick-disconnect crossbar.

- F. STOWAWAY WITH REAR RV ACCESS** **4000-40**
- G. CAR SIDE Q.D.S ONLY** (see PAGE 29) **222**



F. STOWAWAY - 4000-40



OFF-ROAD BUMPER ADAPTER

A. TOW BAR ADAPTER - 035



C. TOW BAR ADAPTER - 035-G2

D. TOW BAR ADAPTER - 039-2

E. TOW BAR ADAPTER (single)- 039-1



F. TOW BAR ADAPTER - 031

G. TOW BAR ADAPTER - 031-5



H. TOW BAR ADAPTER - 034

I. TOW BAR ADAPTER - 034-5

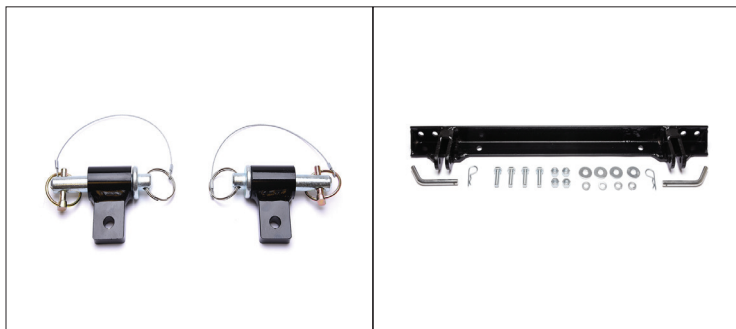

K. BASEPLATE ADAPTER - 030

M. BASEPLATE ADAPTER - 033

ADAPTERS

OFF-ROAD BUMPER ADAPTERS

To adapt ROADMASTER tow bars to aftermarket or off-road bumpers. *Before using these adapters, confirm that the bumper manufacturer has approved the bumper for flat towing.*

- A. Connects motorhome-mounted tow bars to 3/4" thick bumper mounts. Fits 1" or 7/8" diameter hole.....**035**
- B. Connects motorhome-mounted tow bars to 1" thick bumper mounts. Fits 1" or 7/8" diameter hole (not shown)**035-1**
- C. Connects motorhome-mounted tow bars to Smittybilt Gen2 bumpers.**035-G2**

TOW BAR ADAPTERS

Connects Blue Ox, Demco & Curt tow bars to direct-connect ROADMASTER baseplates

With our new universal adapter, customers can use our baseplates to make a clean, professional connection to nearly any brand of tow bar - no tools required

- D. TOW BAR ADAPTER - 1 SET**039-2**
- E. TOW BAR ADAPTER - SINGLE**039-1**
- F. Adapts these tow bars to Blue Ox baseplates: Falcon; Falcon All-Terrain; BlackHawk; BlackHawk 2 All-Terrain (serial #s up to 16,500); Sterling (serial #s up to 14,500) **031**
- G. Adapts these tow bars to Blue Ox baseplates: BlackHawk 2 All-Terrain (serial #s above 16,500), Sterling (serial #s above 14,500) and Nighthawk. Includes collar.....**031-5**
- H. Adapts these tow bars to Demco baseplates: Falcon; Falcon All-Terrain; BlackHawk; BlackHawk 2 All-Terrain (serial #s up to 16,500); Sterling (serial #s up to 14,500)**034**
- I. Adapts these tow bars to Demco baseplates: BlackHawk 2 All-Terrain (serial #s above 16,500), Sterling (serial #s above 14,500) and Nighthawk.)**034-5**
- J. Adapts Curt, Reese, Valley, Eaz-Lift, and Draw-Tite car-mounted tow bars to most ROADMASTER baseplates (will not fit direct-connect baseplates) (not shown)**025**

BASEPLATE ADAPTERS

- K. Adapts ROADMASTER direct-connect baseplates to Blue Ox motorhome mounted tow bars **030**
- L. Adapts ROADMASTER crossbar-style baseplates to most Blue Ox and Demco tow bars. The Guardian rock shield will work with this adapter. Easily unpins for baseplate arm removal. Will not fit direct-connect baseplates**032**
- M. Adapts ROADMASTER crossbar-style baseplates to most Blue Ox and Demco tow bars. Will not work with the Guardian rock shield. Will not fit direct-connect baseplates**033**

ADAPTERS

QUICK-DISCONNECTS

The connection points in ROADMASTER's legacy quick-disconnect ('Q.D.') system, available in full and half sets.

- A. FULL SET QUICK-DISCONNECTS (not shown)**201**
- B. TOW BAR SIDE Q.D.S ONLY.....**221**
- C. CAR SIDE Q.D.S ONLY.....**222**

- D. QUICK-DISCONNECT BASE - COMPLETE ASSEMBLY
INCLUDES:
 CROSSBAR (067)
 CAR SIDE QUICK-DISCONNECTS (222)
 TWO BASE PIN ASSEMBLIES (910029)
 (not shown).....**910021-00**

- E. QUICK-DISCONNECT CROSSBAR ONLY**067**
- F. BASE PINS WITH CABLE AND LINCH PIN (1 PAIR) **910029**
- G. 2-PACK Q.D. LINCH PINS (see PAGE 30) **910024**

H. QUICK-DISCONNECT COVERS

Give your towed vehicle that finished look, and protect your knees. These covers fit over all car-side quick-disconnects when not towing. Made of high-impact, rotationally-molded plastic that is fade- and crack-resistant.**202**

MISC

I. "CAR-IN-TOW" SIGNS

Printed in black on yellow plastic. Required by law in many states. Rear window suction cups included. Will not fade or warp. Dimensions: 5" x 12".

- "I GO WHERE I'M TOWED TO"**330**
- "THIS IS A TOWED CAR"**440**
- "CAR IN TOW AND READY TO GO!"**660**

TWO-SIDED -- "VEHICLE IN TOW"
 AND "I GO WHERE I'M TOWED TO"**770-2**

TOW BAR PADLOCKS

Don't spend your time worrying about a stranger or kids unlatching or removing your safety pins. Replace them with padlocks and peace of mind. Padlocks discourage theft and tampering and protect against accidental release. Hardened steel shackle, double ball locking mechanism, and solid brass tumblers.

- J. QUICK-DISCONNECT PADLOCK - 1 EACH (keyed alike) **301**
- K. 2-PACK QUICK-DISCONNECT PADLOCKS (keyed alike)**302**
- L. 2-PACK QUICK-DISCONNECT PADLOCKS AND 1 COUPLER
 PADLOCK (keyed alike) (not shown) **303**
- M. 4-PACK QUICK-DISCONNECT PADLOCKS (keyed alike)
 (not shown)..... **308**
- N. 1 RECEIVER HITCH LOCK AND 2-PACK QUICK-DISCONNECT
 LOCKS (not shown)..... **304**
- O. COUPLER PADLOCK..... **305**
- P. RECEIVER HITCH LOCK **315**
- Q. 2-PACK RECEIVER HITCH LOCKS (keyed alike)
 (not shown) **316**

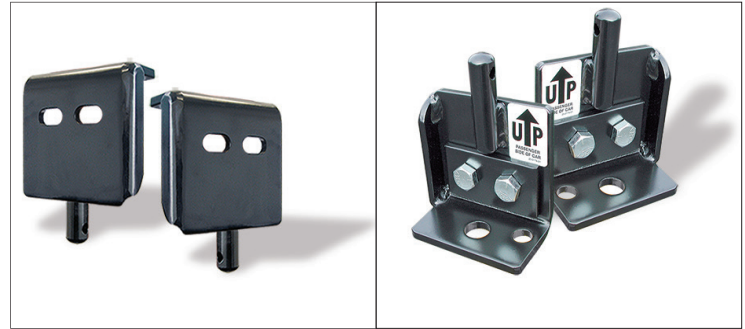

B. TOW BAR Q.D. - **221**

C. CAR SIDE Q.D. - **222**



E. QUICK-DISCONNECT (Q.D.) CROSSBAR - **067**

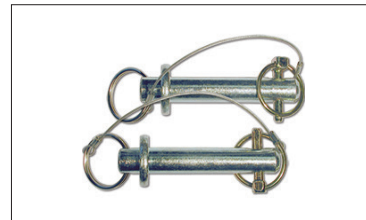

F. BASE PINS & LINCH PINS
 - **910029**

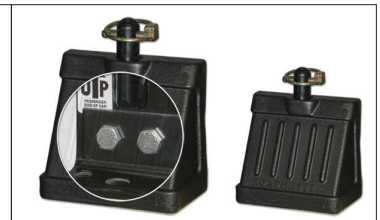

H. QUICK DISCONNECT COVERS
 - **202**

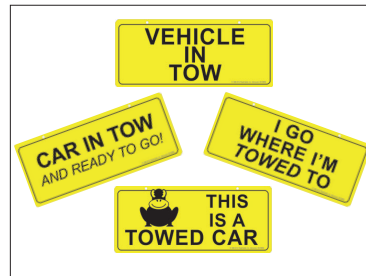

I. "CAR-IN-TOW" SIGNS

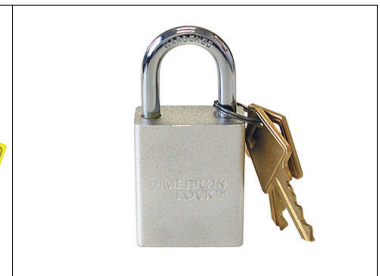

J. Q.D. PADLOCK - **301**



K. Q.D. PADLOCK - 2 PACK - **302**



L. 2-PACK Q.D. PADLOCKS AND
 1 COUPLER PADLOCK - **303**

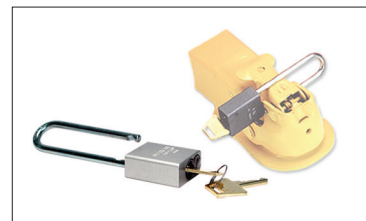

O. COUPLER PADLOCK - **305**



P. RECEIVER HITCH LOCK - **315**

PINS, CLIPS, AND PARTS

It's bound to happen — a pin gets lost or misplaced. Here's a partial list of the pins and clips we have available. If it's not listed here, call us at 800-669-9690 — we are happy to help.



A. - 910049



B. - 910008-00

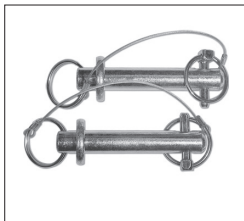

C. - 910029



D. - 910032



E. - 910027

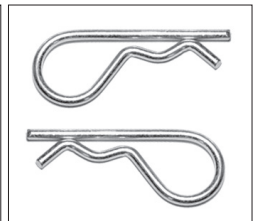

F. - 910028



G. - 910026

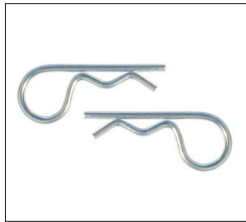

H. - 910023



I. - 910006



J. - 910024



K. - 910003-30



L. - 910003-85



M. - 910007



N. - 910048



O. - 910034



P. - 910031



Q. - 910022

		NIGHTHAWK	STERLING ALL-TERRAIN	STERLING	FALCON ALL-TERRAIN	FALCON 2	FALCON	BLACKHAWK 2 ALL-TERRAIN	BLACKHAWK	STOWMASTER ALL-TERRAIN	STOWMASTER	TRACKER	EAGLE	
A.	2-pack red handle base pin with cable and linch pin	▪	▪	▪	▪	▪	▪	▪	▪					910049
B.	Large base pin with cable and linch pin (one each)	▪	▪	▪	▪	▪	▪	▪	▪					910008-00
C.	2-pack large base pin with cable and linch pin	▪	▪	▪	▪	▪	▪	▪	▪					910029
D.	Coupler pin									▪	▪	▪		910032
E.	Hitch pin and clip for 2" receiver	▪	▪	▪	▪	▪	▪	▪	▪					910027
F.	2-pack clip only for receiver pin	▪	▪	▪	▪	▪	▪	▪	▪					910028
G.	2-pack safety pin with clasp					▪	▪							910026
H.	2-pack storage hairpin									▪				910023
I.	Tracker or 031 adapter pin and clip											▪		910006
J.	2-pack Q.D. linch pins	▪	▪	▪	▪	▪	▪	▪	▪	▪	▪			910024
K.	Component repair kit - Nighthawk / Sterling AT	▪	▪	▪										910003-30
L.	Component repair kit - Falcon AT / Blackhawk 2 AT				▪			▪						910003-85
M.	2-pack 3" pin with lanyard and linch pin for 034, and 034-5 adapters													910007
N.	2 pack of pins and clips for 035, 035-1, and 035-G2 adapters													910048
O.	Hitch pin and clip for 2 1/2" receiver (tow bar requires adapter to fit 2 1/2" receiver)													910034
P.	Safety cable snap hook													910031
Q.	2-pack safety cable quick links													910022

HITCH ACCESSORIES

The leading cause of tow system failure is an "out of level" tow bar — when the tow bar is at an upward or downward slope. These accessories will help you connect at a safe, level height.

Note: Longer safety cables or safety cable extensions may be necessary.

HIGH-LOW HITCH FOR 2" RECEIVERS

The 07 series adapters have a 6,000-pound capacity and a 200-pound maximum tongue weight. The 048 series adapters have a solid-steel shank, allowing a 10,000-pound capacity and 400-pound maximum tongue weight. Fits nearly all two-inch receiver hitches. In two-, four-, six-, eight- and 10-inch sizes.

	size	weight capacity (lbs)	
A.	2"	10,000.....	048-2
B.	2"	6,000.....	072
C.	4"	10,000.....	048-4
D.	4"	6,000.....	070
E.	6"	10,000.....	048-6
F.	6"	6,000.....	076
G.	8"	10,000.....	048-8
H.	10"	10,000.....	048-10

2½" TO 2" HIGH-LOW ADAPTERS

It's an adapter and a drop hitch! These adapters fit 2½" receivers and accept a 2" insert. Great for tow bars, bike carriers, etc. 10,000 lb capacity; 400 lb maximum tongue weight; fits nearly all 2½" receivers.

	size	weight capacity (lbs)	
I.	2"	10,000.....	058-2
J.	4"	10,000.....	058-4
K.	6"	10,000.....	058-6

DUAL HITCH RECEIVERS

With this dual-purpose hitch receiver, you can add a bike carrier or other hitch accessory to the rear of your motorhome. 10,000 lb capacity; 400 lb max tongue weight

L.	BOTH RECEIVERS OFFSET BY 2".....	077-2
M.	ONE RECEIVER OFFSET BY 2", THE OTHER BY 4".....	077-4
N.	ONE RECEIVER OFFSET BY 2", THE OTHER BY 6".....	077-6
O.	ONE RECEIVER OFFSET BY 2", THE OTHER BY 8".....	077-8
P.	ONE RECEIVER OFFSET BY 2", THE OTHER BY 10".....	077-10
Q.	ONE RECEIVER OFFSET BY 0", THE OTHER BY 4".....	068-4
R.	ONE RECEIVER OFFSET BY 0", THE OTHER BY 6".....	068-6
S.	ONE RECEIVER OFFSET BY 0", THE OTHER BY 8".....	068-8
T.	ONE RECEIVER OFFSET BY 0", THE OTHER BY 10".....	068-10

HITCH RECEIVER EXTENSIONS — 6,000-POUND CAPACITY

The hitch receiver extensions provide 7½" and 12", for towing systems that need a little more reach. Rated at 6,000 lbs capacity and 200 lb maximum tongue weight.

U.	7½" HITCH RECEIVER EXTENSION.....	071-75
V.	12" HITCH RECEIVER EXTENSION.....	071

HITCH RECEIVER EXTENSION — 10,000-POUND CAPACITY

This 7½" extension has a solid steel shank. 10,000 lb capacity and a 400 lb tongue weight. A threaded hitch pin hole and bolt eliminate the rattle, wander and sway.

W.	7½" HITCH RECEIVER EXTENSION.....	071-1075
----	-----------------------------------	-----------------

IS YOUR TOWING SYSTEM WITHIN THE SAFE ZONE?

It's easy to bring an out-of-level tow bar into the 'Safe Zone.' Use one of ROADMASTER's hitch accessories to raise or lower the height.

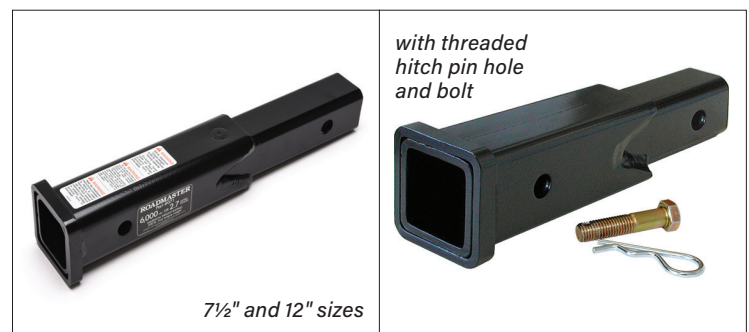
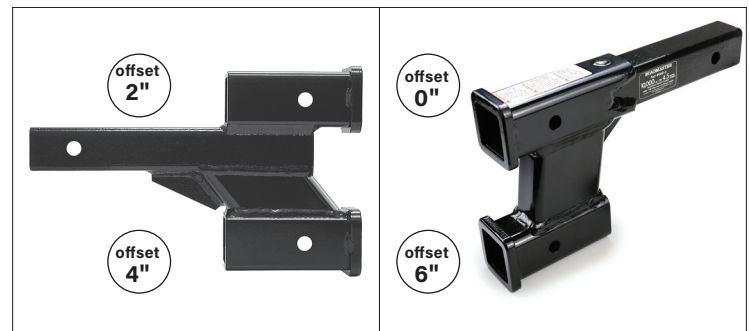
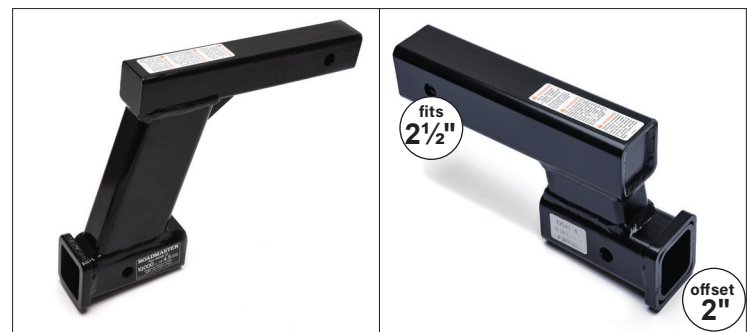
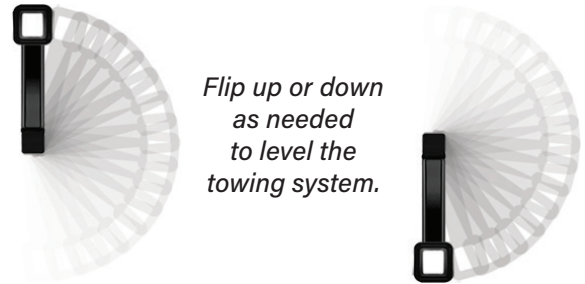
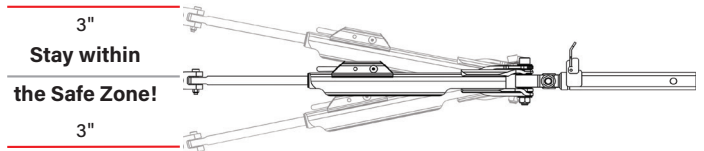

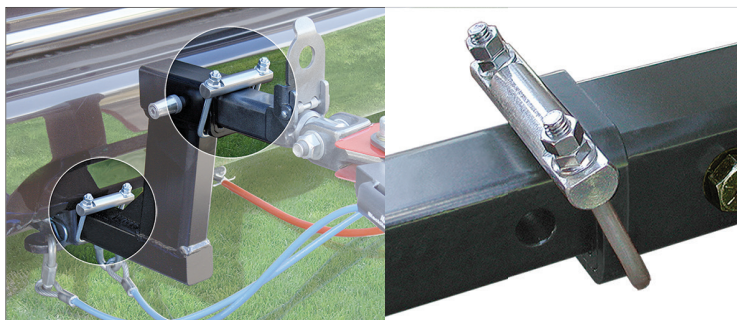

A. QUIET HITCH - 061

QUIET HITCH®

Quiet Hitch stops sway and wander before it begins by eliminating any free play between the receiver and the tow bar (or bike rack, ball mount or whatever you insert). Quiet Hitch keeps your towing combination tracking straight through curves, crosswinds and sudden maneuvers. Especially effective on towing combinations with multiple hitch extensions; also reduces hitch rattle. All three Quiet Hitches bolt on in seconds (The receiver must have a ring or collar around it for Quiet Hitch to attach).

- A. QUIET HITCH FOR 2" HITCH RECEIVERS061
- B. QUIET HITCH FOR 2½" HITCH RECEIVERS062
- C. QUIET HITCH FOR 1¼" HITCH RECEIVERS..... 061-125



D. SPARE TIRE CARRIER FOR MOTORHOMES- 195225-S



F. SPARE TIRE CARRIER FOR VANS, TRUCKS, AND SUVS -195125

SPARE TIRE CARRIERS

ROADMASTER's proactive approach to a flat tire —

- Fits most 2" hitch receivers
- Solid steel construction
- With a ready-to-go spare, you're back on the road quickly.
- Keeps your tires matched
- Carrying your own spare allows you to control the cost.
- You have a place to put your spare, without taking up any valuable cargo space.
- Comes with a two-inch receiver hitch for a tow bar, hitch rack or other hitch-mounted accessory.
- The carrier can be lowered to either side for engine access or ladder clearance.
- Powder-coated for durability and longevity
- Bolts into the receiver to help prevent rattle

Specifications

For 16", 16.5", 19.5", 22.5", 24" and 24.5" dually wheels
10,000 lb capacity, 400 lb tongue weight

- D. SPARE TIRE CARRIER FOR MOTORHOMES & BUSES
2" RECEIVER195225-S
- E. SPARE TIRE CARRIER FOR MOTORHOMES & BUSES
2-1/2" RECEIVER (not shown) 195250-S
- F. SPARE TIRE CARRIER FOR VANS, TRUCKS, AND SUVS
All the convenience and performance features of the original spare tire carrier — automatic locking, the patented hinge mechanism for raising or lowering the spare, and an anti-rattle attachment bolt — for smaller vehicles (will not fit dually wheels).
 - Fits most standard wheels with lug nut circles up to 8"
 - Mounts in a standard 2-inch receiver hitch
 - 6,000 lb capacity, 200 lb tongue weight

.....195125

TOWING ACCESSORIES

SUSPENSION & HANDLING

MOTORHOME MANUFACTURERS MAKE YOUR RV "LIVABLE."
WE HELP MAKE IT "DRIVABLE."

Every "yes" to the following questions is a "yes" for a ROADMASTER suspension solution.

- Does the vehicle "roll" when cornering?
- Does driving for an extended period of time leave you physically exhausted?
- Do passing trucks and crosswinds push and pull you out of your lane?
- Is your rig all over the road — can't keep it between the lines?
- Would you lose control if one of the front tires blew out?
- Does the steering wheel have a mind of its own?
- Is driving a 'white knuckle' experience?
- Does your trailer or 5th wheel push your truck around or frequently sway?
- Can you feel the severe bouncing and jolting of your trailer or 5th wheel on rough roads?

Which component is right for you?

The chart on this page identifies the primary benefits of aftermarket suspension products. Each one has value — for a specific application. Use the chart to make an informed, educated decision about what aftermarket suspension product(s) will enhance your vehicle's stability, handling and maneuverability.

PORPOISING	WIND BUFFETING	BLOW OUT	WHITE KNUCKLING	SOFT STEERING
RUT TRACKING WANDER	SWAY	BOUNCING	ROUGH RIDE	TRAILER SWAY

SUSPENSION & HANDLING

SUSPENSION ISSUE	SOLUTION							
	Shock Absorbers	Air Bags	ROADMASTER RSS Anti-Sway Bar	Bell Crank	ROADMASTER RSS TruTrac Bar	Generic Steering Dampener	ROADMASTER Exact Center & Reflex Steering Stabilizers	ROADMASTER Comfort Ride Shocks & Springs for Trailers & 5th Wheels
Bouncing	✓							✓
Porpoising (up and down movement)	✓							✓
Rough Ride	✓	✓						✓
Trailer Sway								✓
Sway (body roll)			✓					
Soft Steering			✓	✓	✓	✓	✓	
Wind Buffeting			✓		✓		✓	
White Knuckling			✓		✓		✓	
Wander				✓	✓		✓	
Rut Tracking					✓		✓	
Blow Out Protection						✓	✓	
Load Leveling		✓						

SUSPENSION OVERVIEW

ROADMASTER offers a range of high-quality products designed to enhance the performance and stability of recreational vehicles, trailers and 5th wheels. These products offer reliable and smooth handling, improved safety, and greater comfort during long journeys. ROADMASTER's products are the perfect solution for RV and trailer enthusiasts who want to maximize their driving and towing experience.



MOTORHOME SOLUTIONS



Anti-Sway Bars



TruTrac



Reflex



Exact Center



TRAILER & 5TH WHEEL SOLUTIONS



Comfort Ride Shocks



Comfort Ride Springs

What do our customers say?

Anti-Sway Bars

"After installing the (anti-sway) bar, the truck handles like a Ferrari! Unbelievable how this has changed the unfavorable handling characteristics into a finely-tuned, very user-friendly vehicle with exceptional road manners. After the installation, I test-drove doing hard swerves... like being on rails! I highly recommend adding these to your chassis."

— C. Sommer, Fort Wayne, IN

TruTrac

"My F53 chassis would vibrate so bad that it shook the whole motorhome. The only way to stop the vibration was to slow down to 20 mph — which almost got me rear-ended twice. Finally my wife told me, 'I'm not riding in that motorhome any more.' A mechanic told me about TruTrac bars. I had one installed and the vibrations stopped immediately. I drove that motorhome for another 150,000 miles (with my wife back on board) and it was solid as a rock. Buying that ROADMASTER TruTrac bar was the best move I ever made."

— John Kielty, Reno, Nevada

Reflex Steering Stabilizer

"I recently purchased a ROADMASTER Reflex steering stabilizer for my F350, and was amazed at the difference. I'm now able to be proactive behind the steering wheel, rather

than having to react to it. The Reflex steering stabilizer also made an amazing difference when towing a trailer."

— R. Paul, Pilot Hill, CA

Exact Center Steering Stabilizer

"Right away, the noticeable difference was in the steering, of course. Steering was tighter and when coming out of curves, it would want to return to center. Traveling down the freeway was comparable to driving our pickup (Toyota Tundra). I felt it followed the road more than the conditions and ruts of the road. Overall, I look forward to the drive more than I used to when I felt in the past it was going to be a fight between me, the road and the elements. It was a good, solid decision."

— Ronald B, Vancouver, WA

Comfort Ride Shocks & Springs

"Prior to self-installing the ROADMASTER system we had pulled our RV 20,000 miles in about 32 states. Our first pull with the new system was 269 miles from Ohio to Indiana. It was not a long pull, but it was the best 269 miles we have ever pulled. The suspension was absolutely everything that it was advertised to be. It was outstanding."

— Jamey M, Tennessee

ANTI-SWAY BARS

Driving your RV should be an enjoyable experience. And it can be. Adding a set of ROADMASTER anti-sway bars to your suspension has an immediate effect on stability and cornering control.

Does your motorhome (or SUV, pickup truck or Sprinter van) handle like the Queen Mary? Does it pitch and roll with every gust of wind or passing semi, or list to port or starboard on the curves, or waddle over speed bumps, railroad tracks and driveways?

Well, it shouldn't.

As a matter of fact, motorhomes can be made to handle just like what they are — motor vehicles.



SWAY



WHITE KNUCKLING



WIND BUFFETING



SOFT STEERING

Why fight it?



Does your suspension
get the best of you?
...beat you down?
...control you?

THE SOLUTION TO POOR HANDLING IS IN THE SUSPENSION

Adding a set of custom anti-sway bars to your suspension system results in an immediate improvement in handling stability and tracking, especially on the curves.

For many, this is an empowering experience. What was beyond your control just yesterday, is suddenly within it — cornering with confidence, quicker maneuvering and

a remarkably level ride over uneven terrain — all without launching the dishes out of the cupboard.

Even after eight or 10 hours at the wheel you arrive fresh, instead of fatigued, which means you can start enjoying the Grand Canyon, the Grand Tetons or the grandkids right away.

A Better Anti-Sway Bar

Bigger is better — RSS anti-sway bars have a thicker diameter than stock bars (often, a quarter to three-eighths of an inch more). Each incremental increase in diameter has an exponential effect on performance — on average, torsional roll stiffness is increased by 30 percent with every 1/8" increase in diameter. In plain English — RSS anti-sway bars offer up to 90 percent more resistance to sway.

A high-grade alloy — RSS anti-sway bars are made of 4140 "chromoly" steel (a chrome and molybdenum alloy) which is considerably stronger and more durable than the standard spring steel (a 1020 grade) used in many stock anti-sway bars.

A better pivot point — RSS anti-sway bars have polyurethane bushings, which, unlike the rubber used in stock bushings, is impervious to gas, oil and ozone corrosion, is more resistant to abrasion, and doesn't buckle under heavier load weights.

Baked-on finish — Every anti-sway bar is powder-coated. In this process, charged particles of pigment are baked into the surface of the sway bar. They fuse to the metal to form a lustrous, uniform and extremely durable finish.

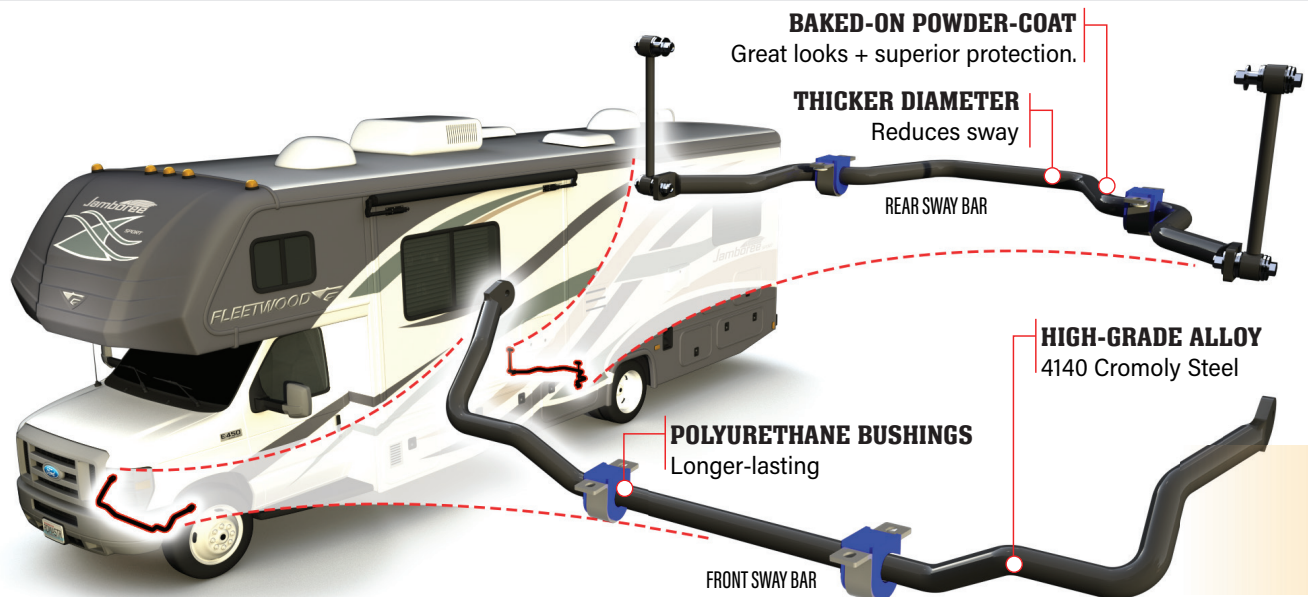

TRUTRAC® STABILIZER

Does your motor-home have leaf spring suspension?

Does it vibrate from side to side?

Are 'wandering,' 'rut tracking' and 'lazy steering' a problem?

Tired and fatigued trying to keep in line going down the road?

TruTrac bars link the chassis to the front axle, eliminating excessive axle side play, without affecting normal up-and-down suspension travel. The result is precise, predictable handling. The benefits are an immediate improvement in both vehicle performance and safety, as well as increased driver comfort — more positive control means less driver fatigue.

Each TruTrac bar comes complete with all mounting hardware, and installs using pre-drilled factory holes — no drilling or welding required. They will not interfere with original equipment or affect any factory warranty.

TruTrac bars are available for Ford F53 chassis (V8 and V10), all Workhorse motorhome chassis (W16, W18, W20, W22 and W24) and Kodiak 45/5500 chassis. They use polyurethane bushings for maximum stability and longevity.

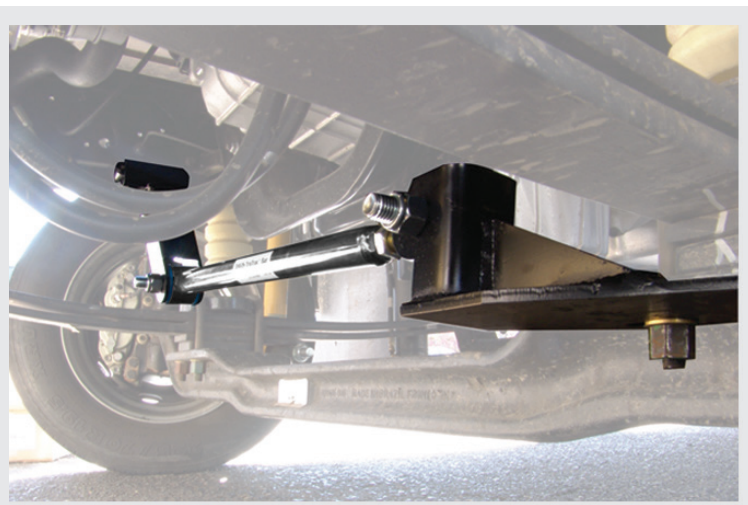

RUT TRACKING



WHITE KNUCKLING



WIND BUFFETING



SOFT STEERING

ISO-Certified Quality System

ISO certification is essential for ROADMASTER Suspension Solutions' Anti-Sway Bars and TruTrac bars as it ensures that these products are manufactured, tested, and maintained to the highest quality standards, providing customers with superior performance, reliability, and ease of installation.



Our certified quality system allows us to produce anti sway bars for OEM suppliers of heavy-duty government vehicles.

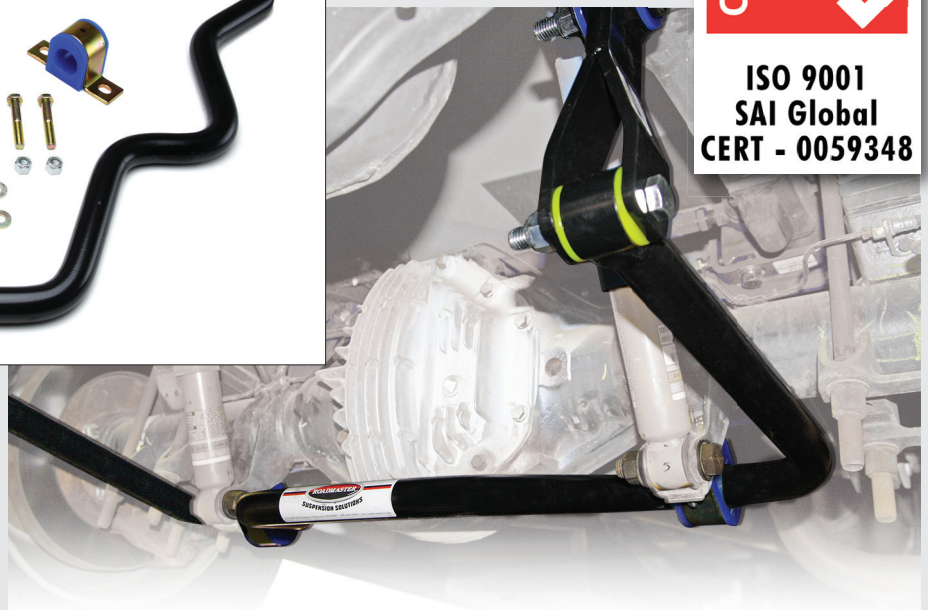

SUSPENSION & HANDLING

FIND YOUR FIT

Scan the QR code or visit fitmaster.roadmasterinc.com/?sus and enter your vehicle's year, make and model. Chances are, we have a ROADMASTER suspension solution for your vehicle.



STEERING STABILIZERS

REFLEX

*Tried-and-True
Stabilizer*



A. REFLEX STEERING STABILIZER - RSSA
(for Larger Motorhomes and Buses)



REFLEX

A tried-and-true favorite, the Reflex steering stabilizer provides front tire blowout protection while greatly reducing driver fatigue. Poor handling characteristics are the unfortunate norm in the RV industry. Reflex greatly improves the drive by compensating for oversteer caused by potholes, rut tracks, other unfavorable road conditions, as well as crosswinds and passing 18-wheelers. Because Reflex is on the job 24/7, it greatly reduces stressful, white knuckle driving while putting the recreation back in RVing.

Reflex helps you handle...

- **FRONT TIRE BLOW OUT** — when you blow out a front tire, your vehicle will make an abrupt turn, causing you to veer into oncoming traffic or off the road. Reflex reacts instantaneously to help maintain control and bring the vehicle back to center.
- **CROSSWINDS AND PASSING TRAFFIC** — works to keep your steering centered and prevents oversteering to help control your vehicle more effectively.
- **ROAD FATIGUE** — Reflex stops the constant wandering, hunting and seeking that cause stress and exhaustion.
- **RUT TRACKING** — ruts cause you to oversteer. With Reflex, your reactions become easier, eliminating oversteer.
- **RUT EDGING** — when your tire drops off the edge of the pavement, it can startle even the most careful driver. Reflex keeps you going straight — helping you control the vehicle until you're safely back on the road.
- **POT HOLES AND DEBRIS** — with Reflex in place, the motorhome stays straight and goes where you want, even through pot holes or road hazards.



B. REFLEX STEERING STABILIZER - RSSC
(for Class B / C Motorhomes and Sprinter Vans)



C. MOUNTING KIT - VARIES
(REQUIRED for Reflex)

- A. REFLEX STEERING STABILIZER **RSSA**
- B. REFLEX STEERING STABILIZER **RSSC**
Check website for vehicle applications.

- C. **MOUNTING KITS**
Vehicle-specific mounting kits are required for Reflex.
Visit fitmaster.roadmasterinc.com to find your fit.
..... **VARIES**



SUSPENSION & HANDLING

Stop fighting the road.
Enjoy the journey.



A. EXACT CENTER - 481225A



B. EXACT CENTER - 481300A



C. MOUNTING KIT - VARIES (REQUIRED for Exact Center) *Many models are available - check website.*

EXACT CENTER

What is it?

Exact Center is a steering stabilizer, but it's different from anything else on the market today.

Why is it unique?

It's proactive. Exact Center aggressively holds your steering at a true center and resists external forces that push it away from center. Other systems do little to hold the steering at center. Instead, they reactively try to bring the steering back to center, but only after it has wandered. Exact Center's substantial force results in a tight, responsive feel without the wander.

- A dramatic improvement in handling and control.
- Improves steering safety & comfort. Reduces driver fatigue.
- Allows for limited backing up with some towed vehicles.
- Prevents rut-tracking, lane wander and fuzzy center.
- Gives a true 'Exact Center' for a sports-car-like feel.
- Stainless steel construction

- A. EXACT CENTER STEERING STABILIZER481225A
 - B. EXACT CENTER STEERING STABILIZER481300A
- Many other models are available:
Check website for vehicle applications.

- C. MOUNTING KITS
- Vehicle-specific mounting kits are required.
Visit fitmaster.roadmasterinc.com to find your fit..
-VARIES



SUSPENSION & HANDLING

FIND YOUR FIT

Scan the QR code or visit fitmaster.roadmasterinc.com/?sus and enter your vehicle's year, make and model. Chances are, we have a ROADMASTER suspension solution for your vehicle.



TRAILER AND 5TH WHEEL RIDE CONTROL

COMFORT RIDE

Floats Your Trailer Over the Toughest Roads



**CARS HAVE SHOCKS.
YOUR TRAILER SHOULD TOO.**

Have you ever opened the door to your trailer and looked into your own personal earthquake zone? Cabinet drawers wide open, knick-knacks all over the floor? The solution is ROADMASTER's Comfort Ride Shock Absorbers and Slipper Springs Systems.

OVER 80% REDUCTION IN ROAD-INDUCED FORCES

Independent tests* show Comfort Ride shock absorber and slipper spring systems reduce energy transmission to trailers/fifth wheels by more than 80 percent, over a variety of surfaces.

- **VERTICALLY MOUNTED SHOCKS** — patented mounting brackets allow the shocks to be mounted vertically, where they have the leverage to limit up-and-down motion on both compression and rebound.
- **ANGLED TO PROVIDE SWAY CONTROL** — because the shocks are angled to the outside, the trailer's weight stays centered over the tires, which helps control sway by limiting lateral suspension travel and side-to-side rocking.



COMFORT RIDE SHOCK ABSORBERS

COMFORT RIDE SHOCK SYSTEMS

- Tandem axle kit for 2-3/8" axle diameters **2450**
- Third axle kit (components for a third 2-3/8" axle) **2450-50**
- Tandem axle kit for 3" axle diameters **2460**
- Third axle kit (components for a third 3" axle) **2460-50**
- Tandem axle kit for 3-1/2" axle diameters **2470**
- Third axle kit (components for a third 3-1/2" axle) **2470-50**

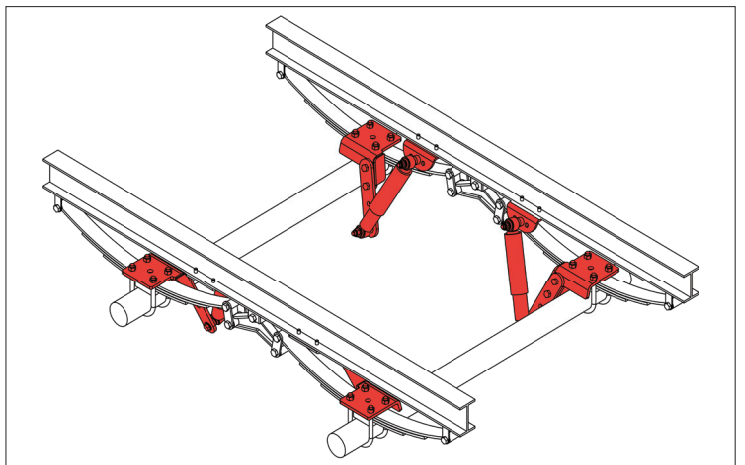

COMFORT RIDE SHOCK ABSORBERS INSTALLED

A COMPLETE SYSTEM

Comfort Ride Shock Absorber and Slipper Spring Kits are available separately, but when installed together offer a more significant improvement in ride quality.



* At the Navistar Proving Grounds in New Carlisle, IN

SUSPENSION & HANDLING



ROUGH RIDE



TRAILER SWAY

To determine your fit, measure the diameter of your axle.



COMFORT RIDE SPRINGS

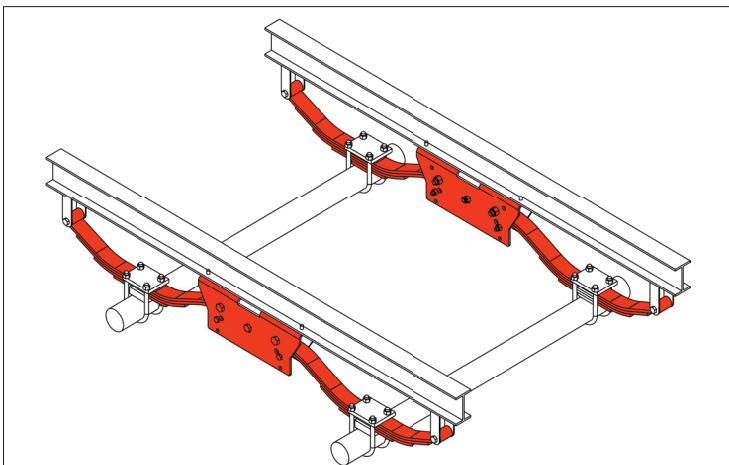

COMFORT RIDE SLIPPER SPRINGS INSTALLED

A SMOOTHER, MORE COMFORTABLE RIDE

Comfort Ride slipper leaf spring systems will significantly reduce the cause of these common suspension-related symptoms:

- **CHUCKING** — The truck is rocked forward and aft when the trailer goes over uneven pavement (dips, frost heaves and the infamous bridge expansion joints).
- **AXLE ROLL-UP** — During braking, the trailer's rear tires are lifted enough to cause a loss in traction (and a rise in the driver's blood pressure).
- **SUSPENSION REBOUND** — When a tire goes over an obstacle, the trailer tips sideways. After clearing the obstacle, the leaf springs (and the trailer with them) rebound like a pogo stick.

WHY DO THEY WORK BETTER?

- **THE AXLES ARE ISOLATED** — the slipper leaf springs attach to a central hanger that isolates each axle, so the two springs are no longer connected. Each spring is free to absorb and dissipate energy independently.
- **FEWER MOVING PARTS** — 10 of the 14 moving parts in a conventional trailer suspension have been eliminated; the remaining four are lubricated with long-life bushings.

SLIPPER SPRING SYSTEMS

Tandem axle kit for axles rated up to 5,000 lbs **2560**
 Third axle kit - 5k (components for one additional axle) **2560-50**

Tandem axle kit for axles rated up to 7,000 lbs **2570**
 Third axle kit - 7k (components for one additional axle) **2570-50**

Tandem axle kit for axles rated up to 8,000 lbs **2580**
 Third axle kit - 8k (components for one additional axle) **2580-50**



ROUGH RIDE



TRAILER SWAY

To determine your fit, simply determine the weight rating of your axle. A ratings sticker can be found on your vehicle's axle itself.

OTHER PRODUCTS

TOW DOLLY

Tow virtually any car on a rugged, adaptable tow dolly with built-in ROADMASTER quality, value and safety features.

A dolly is an ideal choice for anyone who wants to tow multiple vehicles without having to buy a tow bar or install a baseplate.

- Slideable ramps quickly adjust your dolly to tow virtually any car weighing up to 4,250 lbs.
- Unique TrueGrip laser-cut tread pattern provides positive traction in both directions for safe loading and unloading.
- Accu-Lube hubs — easily repack the wheel bearings with a grease gun instead of by hand.
- Built-in electric brakes for safer stops
- Deck swivels for easy cornering and maneuvering
- Ramps, axle and deck are powder-coated for maximum life.
- Complete with tie-down ratchets and straps (fit tire diameters of 30" or less, with 11" or less tread width)
- Easy assembly (average assembly time: one to two hours)

Specifications

Minimum tire width:	34" inside to inside
Maximum tire width:	77" outside to outside
Overall length:	121"
Overall width:	102"
Height at fenders:	29"
Weight — empty:	545 lbs
Tires:	ST205-75 R14 radials
Maximum weight of towed vehicle:	4,250 pounds
Trailer ball size:	2"
Wiring:	7-way connector

A. TOW DOLLY **2050-1**

TOW DOLLY ACCESSORIES

B. SPARE TIRE AND WHEEL **200330-80**

C. TIE DOWN RATCHET (not shown) **2110**

D. TIE DOWN STRAPS Adjustable tie-down strap fits tires with diameters of 30" or less, with 11" or less in tread width **2150**

E. SPARE TIRE CARRIER FOR TOW DOLLY

Mount your spare tire and wheel on your tow dolly using this heavy-duty steel, powder-coated mounting bracket. Bolts on and off in seconds. (spare tire not included) **2000-7**

F. GUARDIAN CARRIER FOR TOW DOLLY

Mount your Guardian rock shield with this heavy duty steel, powder-coated mounting bracket. The Guardian protects your towed vehicle from rock chips and dings.

Guardian sold separately (see PAGE 27) **2000-8**

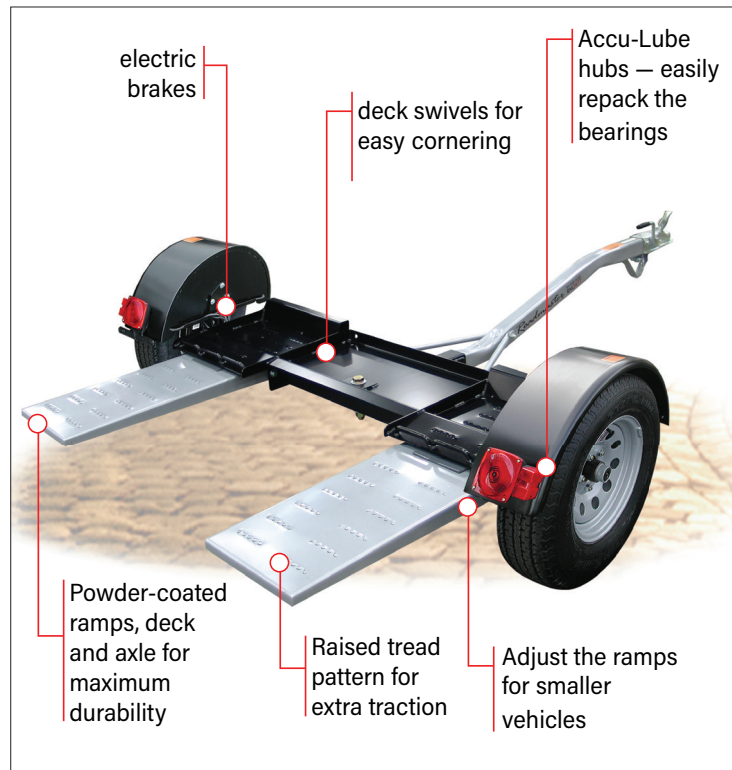

A. TOW DOLLY - 2050-1



B. SPARE TIRE CARRIER - 2000-7
SPARE TIRE - 200330-80

D. TIE-DOWN STRAPS - 2150



F. GUARDIAN CARRIER FOR TOW DOLLY - 2000-8
(Guardian not included)



A. LUBEMASTER - 747



B. TOW BAR CLEANER - 9932



C. VOOM RV CLEANER - 9911 - 9910



D. VOOM GOLD - 9941 - 9940

CARE AND CLEANING

A. LUBEMASTER® SILICONE SPRAY

LubeMaster is the ideal lubricant for tow bars, awning arms, window tracks, folding steps or for hundreds of other applications around the home and RV. It's a dry silicone, which doesn't attract dirt or road grime that can cause binding. Meets Volatile Organic Compound (VOC) standards.

LUBEMASTER747

B. TOW BAR CLEANER

A fast-acting, environmentally-friendly solution that makes cleaning your tow bar a breeze. Removes dirt and grime build-up, penetrating into blind holes and between adjacent surfaces. Melts away road film, diesel exhaust, bugs, tar, grease and grime, dirt and debris. Biodegradable, non-toxic, contains no phosphates or petroleum distillates. Designed for tow bars but works wonders on any surface that's hard to clean.

TOW BAR CLEANER - 22 oz. spray 9932

C. VOOM™ RV CLEANER

Use just one cleaner for all of your RV's cleaning and maintenance. From top to bottom, front to rear, inside and out, Voom RV is the only cleaner you will ever need.

Voom RV is an all-purpose cleaner that's safe for all surfaces not harmed by water. And it's safe for the planet — Voom RV is biodegradable and contains no petroleum distillates. Great for around the home, too!

Exterior uses: aluminum; awnings; black streaks; chrome; bug stains; painted surfaces; rubber; rubber roofs; screens; tar; wheels and more!

Interior uses: appliances; carpets; counter tops; fiberglass; grease; hard water stains; mold and mildew; pet stains; spot cleaning; tubs; toilets; upholstery.

VOOM RV CLEANER - 32 oz. spray9911

VOOM RV CLEANER - 1 gallon..... 9910

VOOM RV CLEANER - 55 gallon drum 9955

D. VOOM™ GOLD RV

A beautiful shine and great UV protection

Simply spray on and wipe off for that showroom shine. Voom Gold protects your finish from fading by encapsulating your RV with a microfine UV and chemical resistant film. The rich luster will deepen with each application protecting the finish from oxidation and deterioration.

Works on both smooth and textured finishes. Shines and renews painted metal, fiberglass, plastic, vinyl, and rubber. Voom Gold contains no acrylic polymers that will yellow and crack over time. Spray on and wipe off for a shine that lasts for months.

VOOM GOLD RV POLISH - 22 oz. spray9941

VOOM GOLD RV POLISH- 1 gallon 9940

INFLATION HOSES & EXTENDERS



Don't settle for less!
Our goal is to be America's first choice for innovative solutions to our customers' needs for wheel and tire performance, safety and beauty.

We won't settle for less. Neither should you.

DUAL TIRE INFLATORS

Easy to install, the inflation hoses attach to your existing valve stem (no need to remove your valve core) allowing you to inflate and equalize your tires in seconds!

A typical dual tire inflator kit includes:

- Four stainless steel hoses with quadruple-crimped plated brass fittings
- Mounting brackets
- Retaining nuts
- Valve caps
- All attachment hardware

A. HUB-MOUNT - STAINLESS STEEL

4-hose kit for 16" to 19½" wheels.....	8001
2-hose kit for 16" to 22½" inner dual wheels	8002
4-hose kit for 22½" wheels.....	8004
2-hose kit for 22½" inner dual wheels.....	8005
4-hose kit for 22½" aluminum wheels.....	8110A
HUB-MOUNT TWO-PLY RUBBER	
4-hose kit for 16" to 19½" wheels.....	8003
2-hose kit for 16" to 19½" inner dual wheels	8006

B. HAND HOLE-MOUNT

HAND HOLE-MOUNT STAINLESS STEEL	
2-hose kit for 16" to 19½" inner dual wheels.....	8009
HAND HOLE-MOUNT TWO-PLY RUBBER	
2-hose kit for 16" to 19½" inner dual wheels.....	8007

C. WHEEL COVER-MOUNT

WHEEL COVER-MOUNT STAINLESS STEEL	
4-HOSE KIT for 16" to 19½" dual wheels, with 45° extenders for front tires	8208

D. WHEEL COVER-MOUNT TWO-PLY RUBBER

4-HOSE KIT for 16" to 19½" dual wheels, with 45° extenders for front tires	8008
--	-------------

DUAL TIRE VALVE EXTENDERS

Enjoy easy access to your hard-to-reach valve stems with these durable, nickel-plated brass valve extenders. They make checking and inflating your dual tires easy. All sets include two extenders and two caps

E. 2" STRAIGHT VALVE EXTENDER.....	80292
F. 3" STRAIGHT VALVE EXTENDER.....	80293
G. 4" STRAIGHT VALVE EXTENDER.....	80294
H. 45° VALVE EXTENDER.....	8029
I. 90° VALVE EXTENDER	802990
J. 135° VALVE EXTENDER.....	8029135
K. 180° VALVE EXTENDER	8029180



DUAL TIRE INFLATOR KIT - typical



A. HUB-MOUNT STAINLESS STEEL - typical

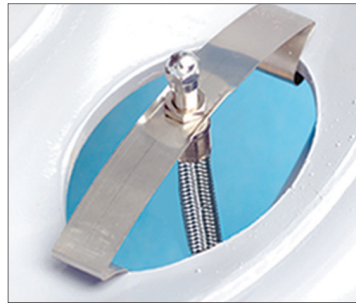

B. HAND HOLE-MOUNT STAINLESS STEEL - typical



C. WHEEL COVER-MOUNT STAINLESS STEEL - typical



D. WHEEL COVER-MOUNT TWO-PLY RUBBER 4-HOSE KIT - 8008



E. 2" STRAIGHT VALVE EXTENDER - 80292



H. 45° VALVE EXTENDER - 8029



I. 90° VALVE EXTENDER - 802990



J. 135° VALVE EXTENDER - 8029135



K. 180° VALVE EXTENDER - 8029180



CUSTOM LUG NUT COVERS - typical



A. LUG NUT COVERS FOR 22 1/2" HUB PILOTED WHEELS - 9005-6



B. UNIVERSAL LUG NUT COVER PLIERS - 8211



C. VALVE STEM END CAPS - 8030



D. DELUXE TIRE PRESSURE GAUGE - 8216



E. LONG DUAL FOOT TIRE PRESSURE GAUGE - 8216-4



F. 90° TIRE PRESSURE GAUGE - 8216-5



G. SHORT DUAL FOOT TIRE PRESSURE GAUGE - 8216-6

LUG NUT COVERS & PRESSURE GAUGES

CUSTOM LUG NUT COVERS

Dress up your plain wheels or replace lost lug nut covers with stainless steel lug nut covers. Designed to stay rust- and corrosion-free for years. Each cover fits snugly over your existing lug nuts and stays in place even in the toughest conditions.

- 1" GM/CHEVROLET - STAINLESS - QTY 8 8010
- 1-1/16" - FORD - STAINLESS - QTY 8 8011
- 1 1/2 - N/A - STAINLESS - QTY 6 8012
- 7/8" - FORD - STAINLESS - QTY 8 8019

SNAP-IN FOUR-PRONG LUG NUT COVERS

- FOR WHEEL COVERS - 4 PACK 9003-4
- SNAP-IN FOUR-PRONG LUG NUT COVERS FOR WHEEL COVERS - 5 PACK 9003-5

- A. LUG NUT COVERS FOR 22 1/2" HUB PILOTED WHEELS (33MM) — STAINLESS STEEL, SIX PACK 9005-6

B. UNIVERSAL LUG NUT COVER PLIERS

Remove and install your lug nut covers quickly with these universal lug nut cover pliers. The rubber-coated handles provide a non-slip grip and their 9" length makes it easy to reach down into deep dish wheels. Made of heavy gauge steel for durability and strength. 8211

C. VALVE STEM END CAPS

These sturdy valve stem caps look great, plus they don't rust, providing you with years of detailed beauty. They also assist in maintaining proper tire air pressure. — six-pack 8030

TIRE PRESSURE GAUGES

D. DELUXE TIRE PRESSURE GAUGE

Proper air pressure is an integral part of a safe road adventure and boosts your gas mileage. These professional-quality, easy-to-read gauges are designed to help you get to your next stop safe and sound while saving you money. Deluxe tire pressure gauge

- For trucks and RVs
- Measures from 10 to 160 psi
- High ANSI grade B accuracy
- Easy-to-read dial
- Protective case
- Convenient pressure release button

..... 8216

E. LONG DUAL FOOT TIRE PRESSURE GAUGE

- Either push or pull onto the valve stem
- For trucks and RVs
- Measures from 10 to 150 psi
- For all valve stem applications

..... 8216-4

F. 90° TIRE PRESSURE GAUGE

Can't reach your valve stem because of those small hand holes? This 90° bend gauge allows you access to those hard-to-reach areas to properly check tire pressure

- Durable stainless steel construction
- Easy-to-read indicator
- Measures in two-pound increments from 10 to 160 psi.

..... 8216-5

G. SHORT DUAL FOOT TIRE PRESSURE GAUGE

- Measures from 10 to 120 psi
- For all valve stem applications
- Spring pocket clip

..... 8216-6

WHEEL COVERS & MIRRORS



WHEEL COVERS

- A. 16" WHEEL SIZE, ALL MAKES*, FRONT & REAR
qty 4..... **7160B0**
- B. 16" WHEEL SIZE, ALL MAKES*, FRONT & REAR
qty 1..... **7160B1**
- C. 16-1/2" WHEEL SIZE, ALL MAKES*, FRONT & REAR
qty 4..... **7165B0**
- D. 16-1/2" WHEEL SIZE, ALL MAKES*, FRONT & REAR
qty 1..... **7165B1**
- E. 19-1/2" WHEEL SIZE, FORD^, FRONT & REAR
qty 4..... **719580**
- F. 19-1/2" WHEEL SIZE, FORD^, FRONT
qty 1..... **719581**
- G. 19-1/2" WHEEL SIZE, FORD^, REAR
qty 1..... **719583**
- H. 19-1/2" WHEEL SIZE, ALL MAKES*, FRONT & REAR
qty 4..... **7195B0**
- I. 19-1/2" WHEEL SIZE, ALL MAKES*, FRONT
qty 1..... **7195B1**
- J. 19-1/2" WHEEL SIZE, ALL MAKES*, REAR
qty 1..... **7195B3**
- K. 3-PRONG CENTER CAP FOR ALL NAMSCO WHEEL COVERS
qty 1..... **9130**
- L. 4-PRONG SNAP-IN LUG NUT COVER FOR WHEEL COVERS
qty 4..... **9003-4**
- M. 4-PRONG SNAP-IN LUG NUT COVER FOR WHEEL COVERS
qty 5..... **9003-5**
*no Budd or split rim
^no split rim

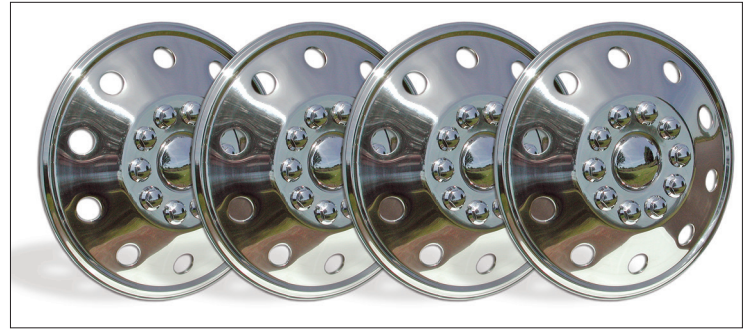

A. STAINLESS STEEL WHEEL COVERS - **7195B0**



L. 4-PRONG SNAP-IN LUG NUT COVER FOR WHEEL COVERS - **9003-4**

VISION PLUS™ PORTABLE SIDE VIEW MIRRORS

Mount these portable mirrors quickly and easily on the door or fender of your tow vehicle. Each mirror extends up to 17" so you can see to back up and monitor how your trailer is tracking.

Adjustable-length nylon strap and non-scratch hooks at the top and bottom of the door or fender hold the 9½" long x 6¾" wide x 2½" deep stainless steel mirror heads securely in place.

The mirrors are powder-coated for durability and good looks; rubber padding helps control vibration and prevent scratching.

- N. VISION PLUS MIRROR (two-pack)..... **6500**
- O. VISION PLUS 5" ROUND CONVEX
WIDE-ANGLE MIRROR..... **6510**
- P. EAGLE VISION 7" SQUARE MIRROR ASSEMBLY **6600**
- Q. WIDE ANGLE SPOT MIRROR, 3¼" X 3¼" **6800**



D. VISION PLUS MIRROR - **6500**

TRAILER EQUIPMENT

LEVEL MASTER™ TRAILER LEVELS

These giant all-in-one RV levels provide visual side-to-side and front-to-rear leveling assistance for trailers, fifth wheels and motorhomes.

Both can be viewed from the driver's seat to help locate the best level location for parking your RV. Each mark on the side-to-side scale indicates one inch of blocking.

The front-to-rear scale is adjustable and can be easily viewed while operating your tongue jack.

The leveling bars are encased in UV-resistant plastic — no leaking or rusting sometimes associated with other levels. Both levels come with instructions to easily install them on your trailer or motorhome. The Level Master bracket (part number 6700BK; see below) can be used with either level.



A. LEVEL MASTER - 6700



B. LEVEL MASTER W/6700BK BRACKET - 6780



C. LEVEL MASTER 2 (without bracket) - 67200



D. LEVEL MASTER BRACKET - 6700BK

E. QUICK FOOT - 725014

- A. LEVEL MASTER — 11" x 2¾" all-in-one level — metal housing.....6700
- B. LEVEL MASTER with 6700BK mounting bracket.....6780
- C. LEVEL MASTER 2 — 10¾" x 2-7/8" all-in-one level — UV-resistant plastic housing.....67200

LEVEL MASTER BRACKET

Adds flexibility to the installation of the Level Master 6700 or 67200 on pin box surfaces that are 25° to 90°.

- Heavy-duty plastic
- Mounting hardware included
- Easy to mount
- Adjustable to fit your needs
- Fits most fifth wheel pin boxes

- D. LEVEL MASTER BRACKET6700BK

QUICK FOOT TONGUE JACK EXTENSION

If your tongue jack takes forever to raise and lower, you need Quick Foot. Just drop it and pin it to gain up to six inches of trailer tongue height in ten seconds or less! Quick Foot is...

- always right where you need it — Quick Foot slides up the tongue jack for easy storage.
- adjustable — extends two, four or six inches.
- tough — Quick Foot is constructed entirely of steel, with corrosion-resistant zinc plating.
- stable — a 7-inch diameter footplate provides maximum stability and resists "sinking in."
- a 'no-brainer' improvement over wooden blocks — wooden blocks are an accident waiting to happen, and the insects hiding in them can be an ecological disaster.

- E. QUICK FOOT TONGUE JACK EXTENSION.725014

Fits virtually all standard tongue jacks - both manual and electric with two-inch diameter inner tubes. 5k-pound tongue weight rating

What Do Our Customers Say?

"I would like to share an experience I recently had with ROADMASTER. I have a Falcon tow bar that I'm sure is 10 to 15 years old. When one of the locking caps broke as a result of sun exposure and wear and tear, I e-mailed ROADMASTER and asked them to send me a replacement and bill me for the parts. They responded by sending me a repair kit with very detailed instructions on doing the fix — at no charge.

I would recommend ROADMASTER to anyone thinking about buying a tow bar. How many companies stand behind their products that long after the sale?"

— **M. and L. Ferner**
Urbandale, Iowa

"I compliment you upon your excellent service department and your philosophy of standing behind what you sell. It's really refreshing to find a business so concerned with customer service."

— **M. and D. Groves**
Salem, Oregon

"We were at The Rally in Atlanta this month and while visiting the vendors, we got a surprise. One of your service agents found, inspected, cleaned and lubed our tow bar. This was a great surprise and we'd like to thank your service people for the great work."

— **F. Gravel**
Southington, Connecticut

"I have all your products and tout them all, as well as your 'over-the-top' customer service, to everyone. You have great people working for you."

— **B. Moore**
Edmonds, Washington

"The level of expertise and commitment to doing the job right speaks volumes for ROADMASTER. I am a big fan and have sent many of our friends to your service center.

I have always felt that we have received good value for our dollar when doing business with ROADMASTER -your equipment is outstanding, and your people make a real difference. ."

— **W. Ervin**
Woodburn, Oregon

"ROADMASTER technical support is always there to assist with any and all problems that may arise."

— **M. Rogers**
Yuma, Arizona

Our Philosophy

Jerry A. Edwards founded ROADMASTER in 1970 with not much more than a "can-do" attitude, plus a philosophy of personal and corporate self-sufficiency.



That ethos has allowed ROADMASTER to flourish, enabling the employment of over 200 people at our over 200,000 sq. ft. of manufacturing facilities.

'Hands-on' Design and Manufacturing

All of our core products are designed, engineered and manufactured in the great Pacific Northwest.

There are two reasons for 'hands-on' manufacturing. The first is simple: quality. "Quality starts on the inside, and when you control the process, you control the quality," as Jerry Edwards says. To our way of thinking, "quality first" is the reason more ROADMASTER towing products are on the road and last longer than any other brand.



The second reason is equally important: it's better to keep the jobs in America.

Over 200,000 Sq Feet of Manufacturing Space

Vancouver, WA
Portland, OR



Plant 1

Utilizing Cutting Edge Technology



The Most Stringent Testing in the Industry

Tow bar and braking testing standards are entirely self-imposed — there are no federal regulations in place. Our standards are the highest in the industry.

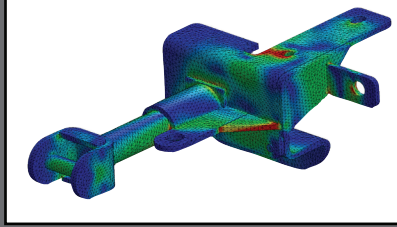

Outstanding Support and Service

Our expert technical support and service team has been helping customers with towing products for a combined 200+ years, ensuring that you get the most robust help available.

Whether you need expert technical guidance, or just want to learn more about our products, we are here for you.



TIME TESTED TIME PROVEN

roadmasterinc.com

800-669-9690

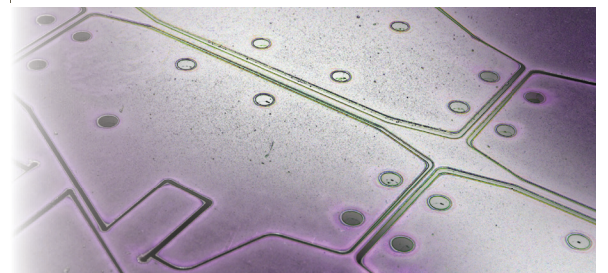
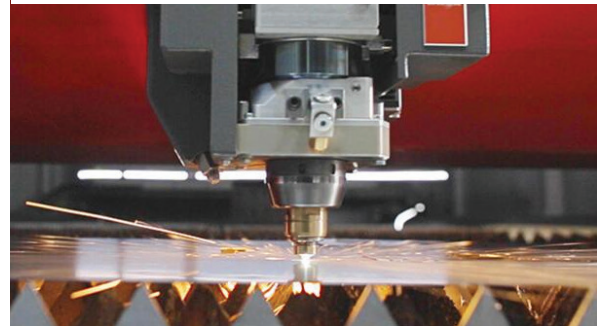
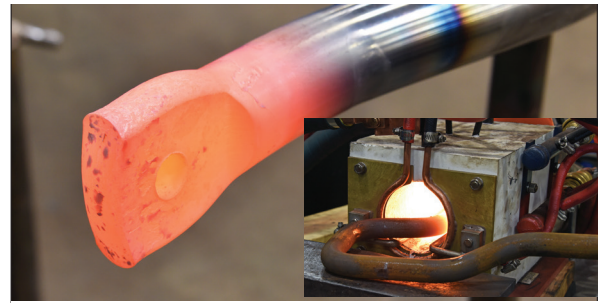

Plant 2

Plant 3





Time Tested • Time Proven

A True American Manufacturer

Roadmaster, Inc. • 6110 NE 127th Ave.
Vancouver, WA 98682 • phone (800) 669-9690
fax (360) 735-9300 • roadmasterinc.com
roadmasterinc.com/patents

All illustrations and specifications contained in this catalog are based on the latest information available at the time of publication. Roadmaster, Inc. reserves the right to make changes at any time, without notice, in material, specifications and models, or to discontinue models.

® , TM & © 1999-2023 ROADMASTER, Inc.

All rights reserved. 853079-19 06.23